

EB 506P



Pel-Job

INCOMPARABLE POWER



With its exceptional power and stability, and its extraordinary sturdiness, the wheeled Pel-Job EB 506 works with maximum speed and efficiency on the most difficult sites. Its high degree of mobility, its remarkable quietness and its compact dimensions make it the ideal machine for all earthwork in urban areas. Faithful to the Pel-Job tradition, this machine meets a strict specification with a single objective: to make a difference on the site.

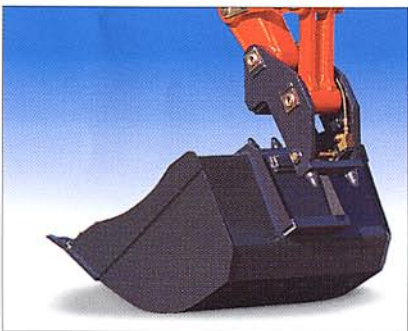

A Pel-Job exclusive: the quick coupling system available as an option enables bucket or accessory to be changed without the operator leaving the cab. Appreciated by all users, this device saves a lot of time and increases comfort considerably without altering the bucket's performances or sequence of operations.

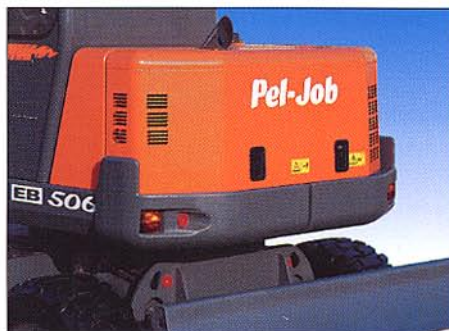

The wrap-around shape of the counterweight protects the back of the machine perfectly and makes it possible to work on the narrowest sites.



Thanks to its compact dimensions and the boom's hydraulic offset, the EB 506 is at ease in all site configurations, even alongside a wall.





The new articulated boom increases the EB 506's versatility. The boom's additional joint reduces the equipment's overall dimensions and makes it possible to position the bucket on a larger ground surface, even in the immediate proximity of the machine.



The sturdy boom king post provides a total range of movement of 130°. The double-fork pivot and the long king pin contribute to the assembly's rigidity. All the pins are fitted with bushes to ensure long life and to increase service intervals.



Pel-Job quality down to the last detail: the hydraulic pipes are zinc-coated and passivated for better protection against corrosion and are mounted on the top part of the boom protected from knocks. The boom cylinder's rod is fully protected against any knocks by sturdy guard. Each cylinder is well-dimensioned and equipped with cushions to absorb shock and prevent spillage.



ADVANCED HYDRAULICS

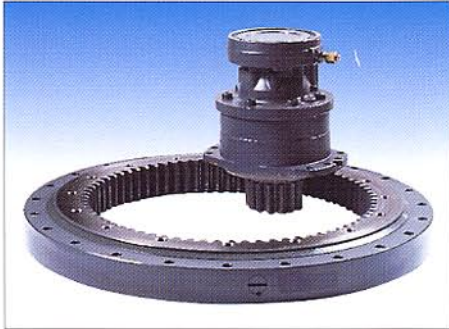
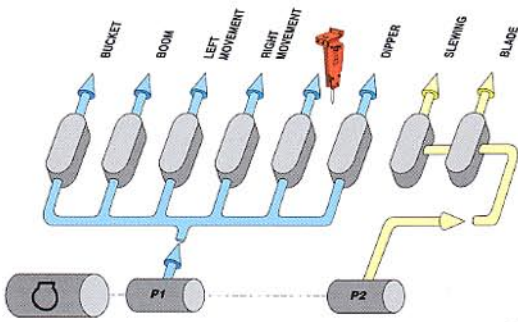

A Pel-Job exclusive: the radial piston slow slewing motor. This motor has a very high starting torque for flexible manoeuvres, and drives the crown directly without a mechanical reducer. The result is fewer moving parts and therefore less risk of wear. The automatic hydraulic brake integrated in the slewing motor immobilises the turret in all positions and guarantees optimum working safety even on a slope.

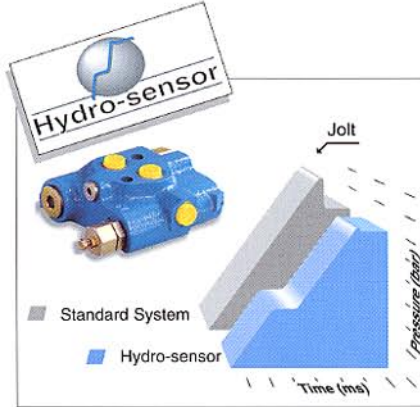

The hydrosensor valve (Pel-Job patent) on the slewing circuit damps the pressure peaks and hydraulic shocks common on starting and stopping on conventional circuits. The result: a progressive pressure increase, greater flexibility and precision and less stressed and therefore more reliable mechanical parts

- ➔ *Continuous and immediate load sensing control of the hydraulic pump's flow and pressure to suit the work done by the excavator.*
- ➔ *All hydraulic functions are independent and can be operated simultaneously: more operating comfort and productivity.*
- ➔ *Control valves with closed centre: pump flow zero on standby, no unnecessary oil circulation. No loss of power or deterioration of oil by overheating.*
- ➔ *Hydraulic power continuously adapted to suit the load: optimum use of the engine's power.*
- ➔ *Straight-line travel maintained even when the equipment or the turret are moving: more safety*
- ➔ *Very great precision of the controls, even with a large load: safety of handling work.*
- ➔ *Hydraulic priority on braking and steering circuits: more safety.*
- ➔ *Four-speed hydrostatic transmission.*

EXCEPTIONAL ACCESSIBILITY

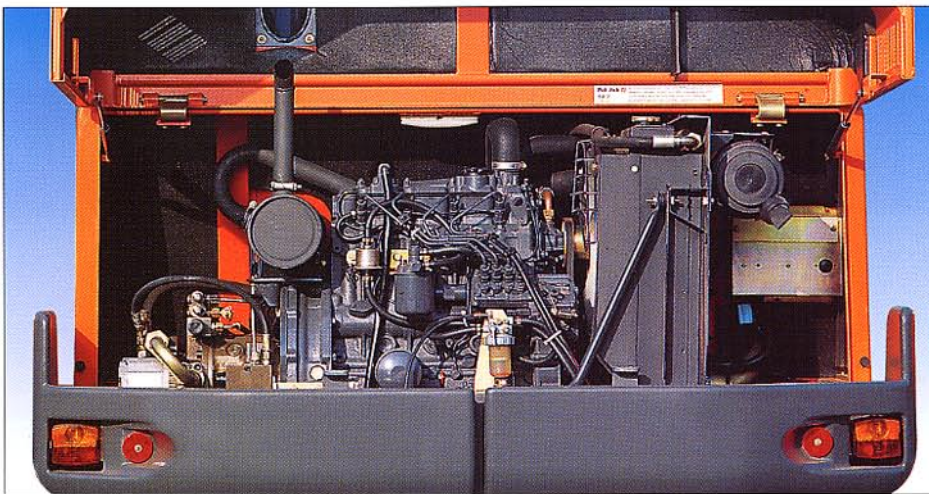

The back cover opens completely, giving excellent access to the engine and hydraulic pumps. All maintenance and checking points are conveniently located close to hand.

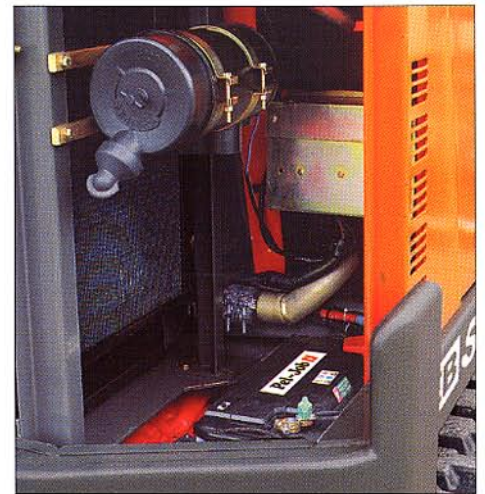

The radiators of the hydraulic circuit and engine are placed side by side to facilitate their cleaning. The battery and the air filter too are very easily accessible.

FOOLPROOF SECURITY



The EB 506 is equipped as standard with a sturdy blade controlled by two rams fitted with safety valves. In option, this can be replaced by two separately controlled stabilisers to which a removable blade can be added.

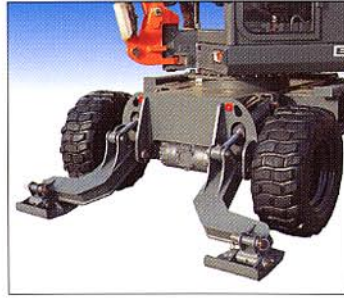

The steering front axle is oscillating with an angle of 15° in order to go over all terrains. A hydraulic oscillation locking device ensures perfect stability of the excavator in all positions.

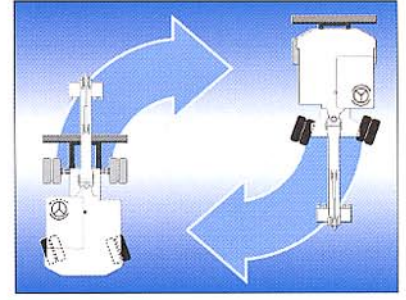

Pel-Job's Auto-Reverse system, available as an option, automatically reverses the steering direction when the excavator is facing the back. Thanks to this exclusive system, the wheels are always oriented in the direction of rotation of the steering wheel, for greater precision and safety in operation.

FIRST CLASS COMFORT



The side consoles supporting the manipulators are rigidly linked to the seat's suspension: operating precision is independent of the machine's movements and the operator is sure of finding an operating position ideally suited to him.

- ➔ *Wide, spacious cab mounted on rubber mountings.*
- ➔ *Advanced soundproofing.*
- ➔ *Suspended seat with multiple settings and fabric covered.*
- ➔ *Power-assisted hydraulic controls mounted on side brackets rigidly linked to the seat.*
- ➔ *Sliding side window and wind-screen folding under the roof.*
- ➔ *Heating and ventilation.*
- ➔ *Excellent all-round visibility.*
- ➔ *Ergonomic armrests.*
- ➔ *Puma System.*

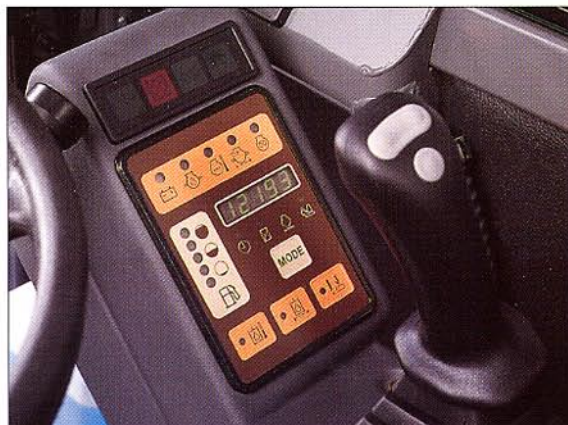
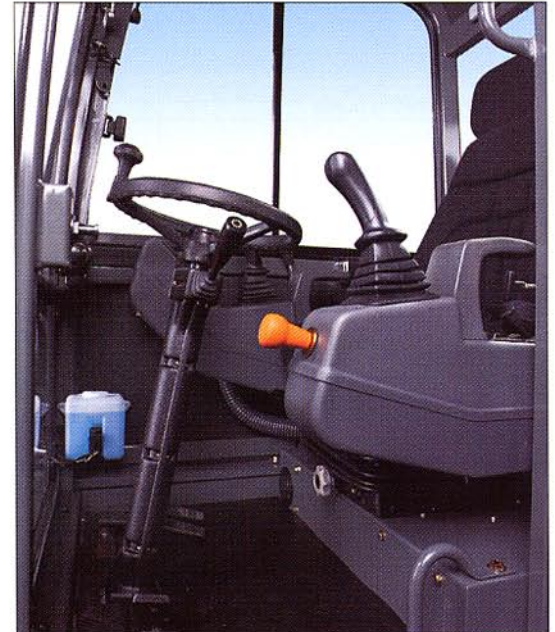

The PUMA system on the EB 506 continuously monitors all the machine's vital functions and immediately informs the operator if there is a fault. The operator is therefore free to concentrate fully on operating the machine.



Pel-Job's new ergonomic manipulators feel good and are complemented by side arm rests which give a natural and very comfortable operating position.

TECHNICAL DATA	
Operational weight with 12x18 wheels, 600 mm bucket and 1500 mm arm	
With single-piece boom and blade	5125 kg
With articulated boom and blade	5295 kg
Bucket performances	
Excavation force	3654 daN
Tear-out force	2733 daN
Buckets	
Standard bucket	600 mm (142 litres)
Other backhoe buckets available	from 350 to 900 mm (from 71 to 231 litres)
Cleaning bucket	1500 mm (244 litres)
Engine	
Type	Perkins 104.22, water-cooled, 4-cylinder engine
Cubic capacity	2216 cc
Rated horsepower (SAE.J1349)	50 hp (36.8 kW) at 2800 rpm
Installed horsepower (D. 80/1269 CEE)	45.8 hp (33.7 kW) at 2500 rpm
Maximum torque (D. 80/1269 CEE)	139 Nm at 2050 rpm
Battery / Alternator	12 V - 95 AH / 12 V - 55 A
Engine monitoring	PUMA electronic control unit
Fuel tank capacity	80 litres
Maximum slope and bank	30° / 58% (engine's lubrication limit)
Load Sensing hydraulic system	
Controls	Power-assisted hydraulic controls
Equipment and travel pump	Variable capacity Load Sensing pump
Delivery and pressure	112.5 litres/min. at 250 bar
Delivery of attachment circuit	75 litres/min.
Blade and slewing pump	Gear pump
Delivery and pressure	36 litres/min. at 250 bar
Total capacity of circuit / tank	106 / 70 litres
Slewing system	
Axial piston slewing motor	Direct drive of the ring gear without reduction unit
Absorption of hydraulic shocks	Hydrosensor Shockless valve
Braking of slewing	Automatic multi-disc brake
Slewing speed	8 rpm
Hydrostatic transmission with 4 drive wheels	
Tyres	12 -18 (Option : 15.5/55 R 18)
Twin wheels (optional)	7.5 x 18
Transmission type	Hydrostatic with reversing gear and 4 forw./rev. gears
Travel speeds	0 - 3 km/h, 0 - 6 km/h, 0 - 9 km/h and 0 - 18 km/h
Tractive force	2865 daN
Braking on the four wheels	Multi-disc brakes with hydraulic control
Blade or stabilizers with safety valves incorporated to the cylinders	
Standard equipment	Blade for grading work and stabilisation
Optional equipment 1	2 stabilizers fitted instead of the blade
Optional equipment 2	A removable blade fitted on the stabilizers
Front steering axle with hydraulic locking of slewing	
Turning radius (outside the wheels)	5115 mm (with 15.5/55 R 18 tyres)
Automatic steering inversion	Auto-Reverse Pel-Job system (option)
Sound level (dynamic measurement)	
Sound level exterior (LwA)	99 dBA
Sound level in the cab (LpA)	80 dBA
Heated and ventilated cab	
Adjustable suspended seat	●
Seatbelt	●
FOPS 1 and TOPS protection	●
Radio pre-equipment	● (with antenna and wiring)
Lighting	3 working lights

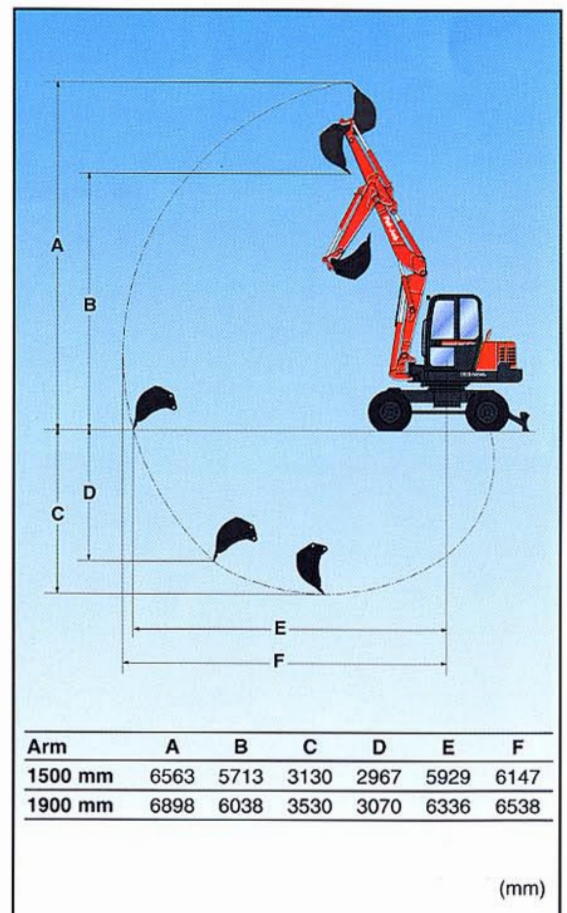
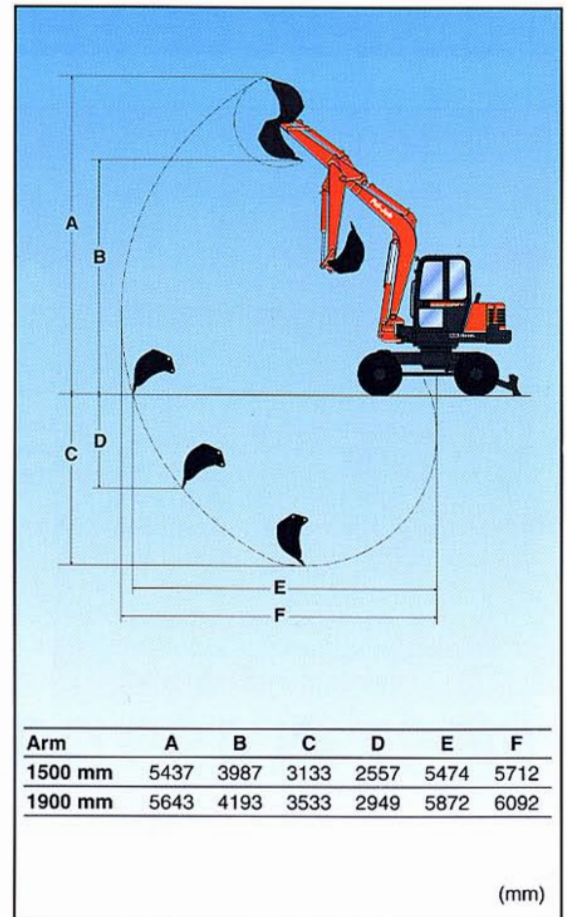

● : standard equipment - Other options and accessories available : Hydraulic quick-release coupling - Revolving light - Rear working light - Organic hydraulic oil - Working light on boom - Safety valve for

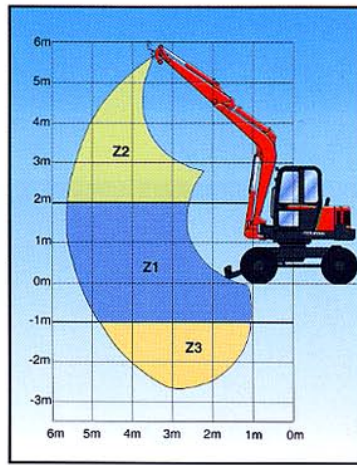
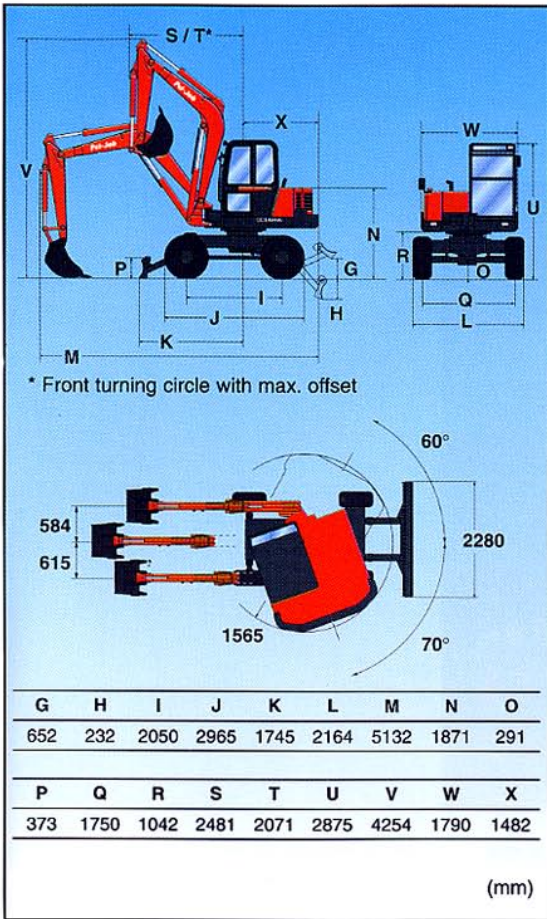

EB 506

SINGLE-PIECE BOOM

LIFTING CAPACITIES

These values are given for a machine without a bucket or quick connecting link, and equipped with standard tyres for all the height considered on each zone Z.
The lifting capacity represents 75% of the tipping load or 87% of the hydraulic limit.



Lifting capacity in rear longitudinal position and resting on the blade or the stabilizers.

Lifting capacity in total rotation over 360° with the blade or the stabilizers raised.

Horizontal Range		2 m	3 m	4 m	max: 4,8 m
1500 mm	Rear longitudinal position	Z2	1235*	970*	
		Z1	2620*	1565*	1240*
		Z3	3135*	2220*	
	360° rotation	Z2	1235*	970*	
		Z1	2620*	1440	960
		Z3	2850	1460	

Horizontal Range		2 m	3 m	4 m	max: 5,2 m
1900 mm	Rear longitudinal position	Z2	1260*	970*	
		Z1	1965*	1260*	1075*
		Z3	2955*	2145*	1565*
	360° rotation	Z2	1235	970*	
		Z1	1965*	1425	945
		Z3	2795	1430	950

* Hydraulic limit

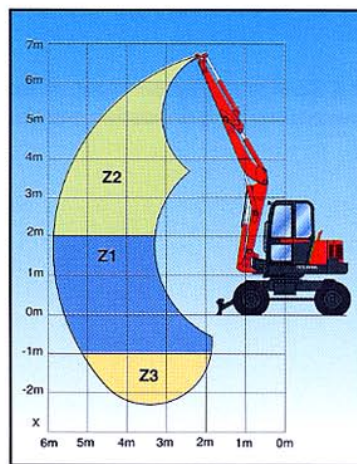
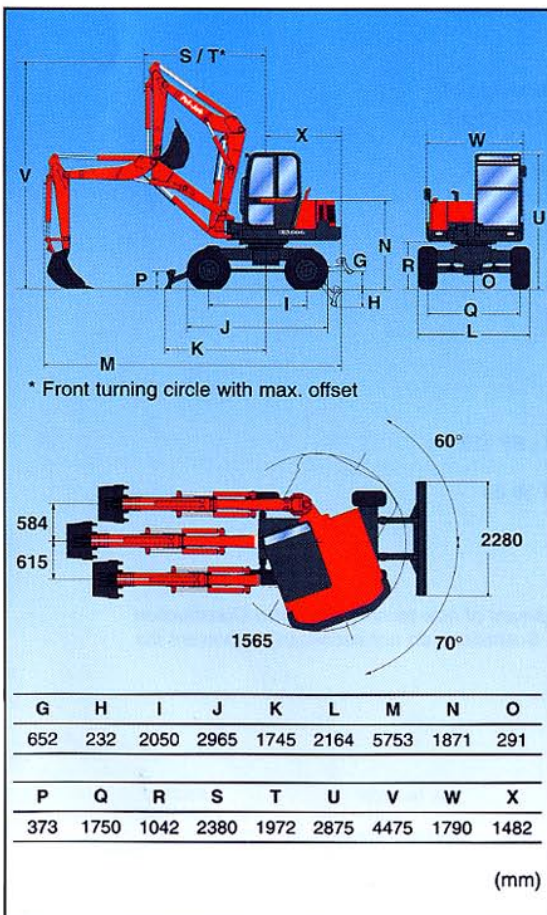

EB 506

ARTICULATED BOOM

LIFTING CAPACITIES

These values are given for a machine without a bucket or quick connecting link, and equipped with standard tyres for all the height considered on each zone Z.
The lifting capacity represents 75% of the tipping load or 87% of the hydraulic limit.



Lifting capacity in rear longitudinal position and resting on the blade or the stabilizers.

Lifting capacity in total rotation over 360° with the blade or the stabilizers raised.

Horizontal Range		2 m	3 m	4 m	max: 5,3 m
1500 mm	Rear longitudinal position	Z2	2100*	1130*	915*
		Z1	1955*	1130*	1040*
		Z3	2555*	1530*	1225*
	360° rotation	Z2	2100*	1130*	890
		Z1	1955*	1130*	815
		Z3	2395	1230	820

* Hydraulic limit

Horizontal Range		2 m	3 m	4 m	max: 5,7 m
1900 mm	Rear longitudinal position	Z2	1145*	760*	805*
		Z1	1890*	1175*	820*
		Z3	2645*	1430*	1195*
	360° rotation	Z2	1120	735	
		Z1	1620*	1150	795
		Z3	2350	1210	805



A technology to suit your needs.

Choosing Volvo Construction Equipment machines means having high quality and high productivity. It also means being assured of the reliability of machines built to take into account the needs of the operator as well as those of the environment. From each range you can choose the machine most suited to your needs, enabling you to improve the profitability of even the most difficult site in complete safety.

Compact & Service Equipment offers a complete range of compact excavators, compact loaders and excavators/loaders.

Ecomat Industrie S.A. - Avenue Charles de Gaulle - BP 119
F - 01303 Belley Cedex
Tél. : +33 (0)4 79 81 15 09 - Fax : +33 (0)4 79 81 39 63

In order to adapt their products continuously to suit the needs of users and the development of new techniques, Volvo Construction Equipment Group reserves the right to change their specifications without notice. The illustrations do not necessarily represent the standard versions of the machines.

**Volvo Construction
Equipment Group**

Ref. No. KON 2907726
CST 21 5 432 1009
Printed in France 07.98 N English