

EB 706P



Pel-Job

INCOMPARABLE POWER



With its exceptional power and stability, and its extraordinary sturdiness, the wheeled Pel-Job EB 706 works with maximum speed and efficiency on the most difficult sites. Its high degree of mobility, its remarkable quietness and its compact dimensions make it the ideal machine for all earthwork in urban areas. Faithful to the Pel-Job tradition, this machine meets a strict specification with a single objective: to make a difference on the site.

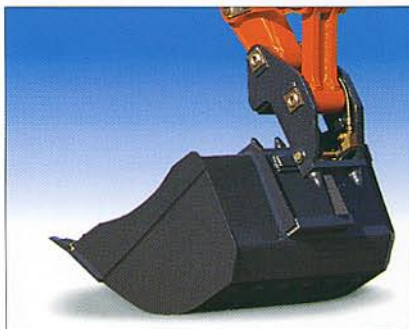

A Pel-Job exclusive: the quick coupling system available as an option enables bucket or accessory to be changed without the operator leaving the cab. Appreciated by all users, this device saves a lot of time and increases comfort considerably without altering the bucket's performances or sequence of operations.



The wrap-around shape of the counterweight protects the back of the machine perfectly and makes it possible to work on the narrowest sites.



Thanks to its compact dimensions and the boom's hydraulic offset, the EB 706 is at ease in all site configurations, even alongside a wall.



The new articulated boom increases the EB 706's versatility. The boom's additional joint reduces the equipment's overall dimensions and makes it possible to position the bucket on a larger ground surface, even in the immediate proximity of the machine.

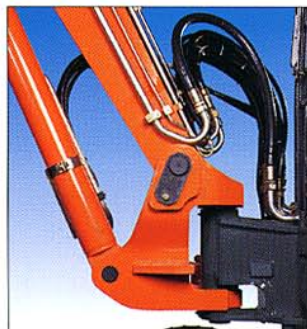

The sturdy boom king post provides a total range of movement of 130°. The double-fork pivot and the long king pin contribute to the assembly's rigidity. All the pins are fitted with bushes to ensure long life and to increase service intervals.



Pel-Job quality down to the last detail: the hydraulic pipes are zinc-coated and passivated for better protection against corrosion and are mounted on the top part of the boom protected from knocks. The boom cylinder's rod is fully protected against any knocks by sturdy guard. Each cylinder is well-dimensioned and equipped with cushions to absorb shock and prevent spillage.



ADVANCED HYDRAULICS

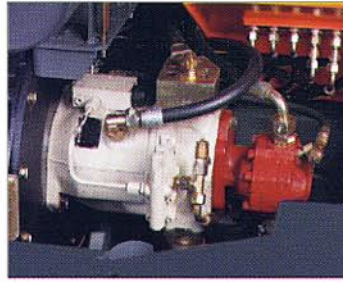
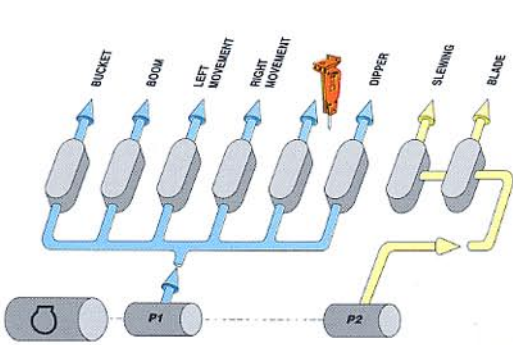

A Pel-Job exclusive: the radial piston slow slewing motor. This motor has a very high starting torque for flexible manoeuvres, and drives the crown directly without a mechanical reducer. The result is fewer moving parts and therefore less risk of wear. The automatic hydraulic brake integrated in the slewing motor immobilises the turret in all positions and guarantees optimum working safety even on a slope.

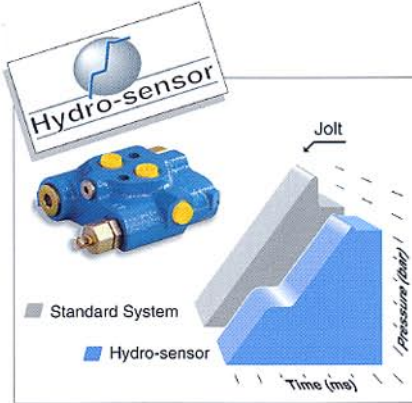

The hydrosensor valve (Pel-Job patent) on the slewing circuit damps the pressure peaks and hydraulic shocks common on starting and stopping on conventional circuits. The result: a progressive pressure increase, greater flexibility and precision and less stressed and therefore more reliable mechanical parts.

- ➔ *Continuous and immediate load sensing control of the hydraulic pump's flow and pressure to suit the work done by the excavator.*
- ➔ *All hydraulic functions are independent and can be operated simultaneously: more operating comfort and productivity.*
- ➔ *Control valves with closed centre: pump flow zero on standby, no unnecessary oil circulation. No loss of power or deterioration of oil by overheating.*
- ➔ *Hydraulic power continuously adapted to suit the load: optimum use of the engine's power.*
- ➔ *Straight-line travel maintained even when the equipment or the turret are moving: more safety*
- ➔ *Very great precision of the controls, even with a large load: safety of handling work.*
- ➔ *Hydraulic priority on braking and steering circuits: more safety.*
- ➔ *Four-speed hydrostatic transmission.*

EXCEPTIONAL ACCESSIBILITY



A wide central cover gives excellent access to a service platform where all the machine's hydraulic components are grouped together. Access to the control valves, rotating joint and slewing motor is immediate, which greatly facilitates all maintenance operations.

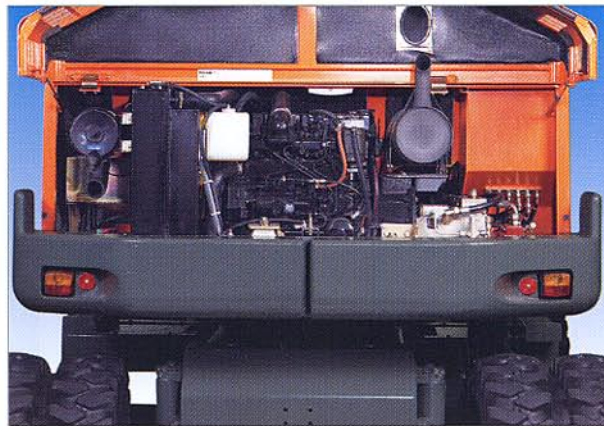

The back cover opens completely, giving excellent access to the engine and hydraulic pumps. All maintenance and checking points are conveniently located close to hand.

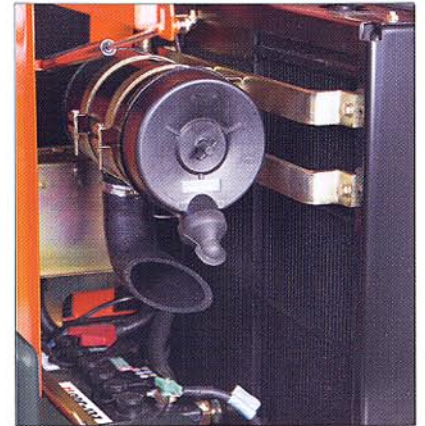

The radiators of the hydraulic circuit and engine are placed side by side to facilitate their cleaning. The battery and the air filter too are very easily accessible.

FOOLPROOF SECURITY



The EB 706 is equipped as standard with a sturdy blade controlled by two rams fitted with safety valves. In option, this can be replaced by two separately controlled stabilisers to which a removable blade can be added.

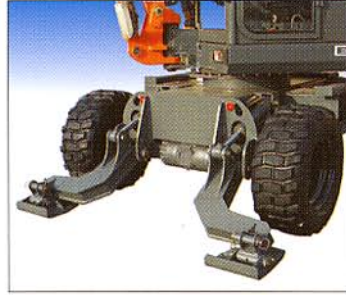

The steering front axle is oscillating with an angle of 15° in order to go over all terrains. A hydraulic oscillation locking device ensures perfect stability of the excavator in all positions.

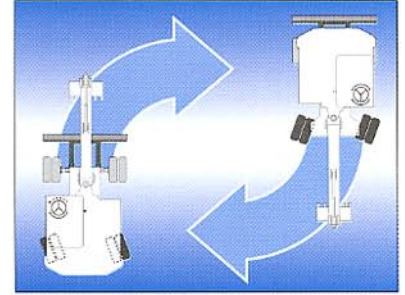

Pel-Job's Auto-Reverse system, available as an option, automatically reverses the steering direction when the excavator is facing the back. Thanks to this exclusive system, the wheels are always oriented in the direction of rotation of the steering wheel, for greater precision and safety in operation.

FIRST CLASS COMFORT



The side consoles supporting the manipulators are rigidly linked to the seat's suspension: operating precision is independent of the machine's movements and the operator is sure of finding an operating position ideally suited to him.

- ➔ *Wide, spacious cab mounted on rubber mountings.*
- ➔ *Advanced soundproofing.*
- ➔ *Suspended seat with multiple settings and fabric covered.*
- ➔ *Power-assisted hydraulic controls mounted on side brackets rigidly linked to the seat.*
- ➔ *Sliding side window and wind-screen folding under the roof.*
- ➔ *Heating and ventilation.*
- ➔ *Excellent all-round visibility.*
- ➔ *Ergonomic armrests.*
- ➔ *Puma System.*

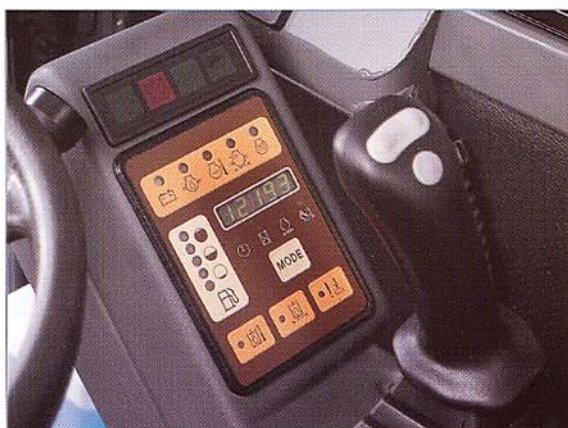
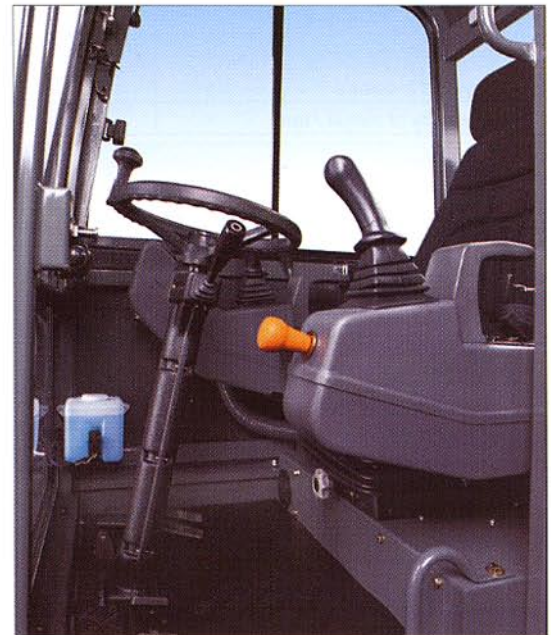

The PUMA system on the EB 706 continuously monitors all the machine's vital functions and immediately informs the operator if there is a fault. The operator is therefore free to concentrate fully on operating the machine.



Pel-Job's new ergonomic manipulators feel good and are complemented by side arm rests which give a natural and very comfortable operating position.

TECHNICAL DATA

Operational weight with twin wheels, 750 mm bucket and 1800 mm arm

With single-piece boom and blade	7250 kg
With articulated boom and blade	7395 kg

Bucket performances

Excavation force	5190 daN
Tear-out force	3450 daN

Buckets

Standard bucket	750 mm (246 litres)
Other backhoe buckets available	from 325 to 900 mm (from 98 to 306 litres)
Cleaning bucket	1500 mm (244 litres)

Engine

Type	Mitsubishi S4S, water-cooled, 4-cylinder engine
Cubic capacity	3331 cc
Installed horsepower (ECE R24)	56 hp (41 kW) at 2200 rpm
Maximum torque	204 Nm from 1350 to 1550 rpm
Battery / Alternator	12 V - 95 AH / 12 V - 50 A
Engine monitoring	PUMA electronic control unit
Fuel tank capacity	110 litres
Maximum slope and bank	30° / 58% (engine's lubrication limit)

Load Sensing hydraulic system

Controls	Power-assisted hydraulic controls
Equipment and travel pump	Variable capacity Load Sensing pump
Delivery and pressure	160 litres/min. at 250 bar
Delivery of attachment circuit	105 litres/min.
Blade and slewing pump	Gear pump
Delivery and pressure	50 litres/min. at 260 bar
Total capacity of circuit / tank	131 / 73 litres

Slewing system

Axial piston slewing motor	Direct drive of the ring gear without reduction unit
Absorption of hydraulic shocks	Hydrosensor Shockless valve
Braking of slewing	Automatic multi-disc brake
Slewing speed	10 rpm

Hydrostatic transmission with 4 drive wheels

Twin wheels as standard	Tyres : 8-25 x 20
Transmission type	Hydrostatic with reversing gear and 4 forw./rev. gears
Travel speed	0 - 3.5 km/h, 0 - 6.5 km/h, 0 - 12 km/h and 0 - 20.5 km/h
Max. tractive force	3100 daN
Braking on the four wheels	Multi-disc brakes with hydraulic control

Blade or stabilizers with safety valves incorporated to the cylinders

Standard equipment	Blade for grading work and stabilisation
Optional equipment 1	2 stabilizers fitted instead of the blade
Optional equipment 2	A removable blade fitted on the stabilizers

Front steering axle with hydraulic locking of slewing

Turning radius (outside the wheels)	5500 mm (with twin wheels)
Automatic steering inversion	Auto-Reverse Pel-Job system (option)

Sound level (dynamic measurement)

Sound level exterior (LwA)	100 dBA
Sound level in the cab (LpA)	83 dBA

Heated and ventilated cab

Adjustable suspended seat	●
Seatbelt	●
FOPS 1 and TOPS protection	●
Radio pre-equipment	● (with antenna and wiring)
Lighting	3 working lights

● : standard equipment - Other options and accessories available :

Hydraulic quick-release coupling - Revolving light - Rear working light - Organic hydraulic oil - Working light on boom - Safety valve for handling with overload indicator - PUMA anti-theft system - Special paint

Refer also to the Pel-Job buckets and accessories catalogue.

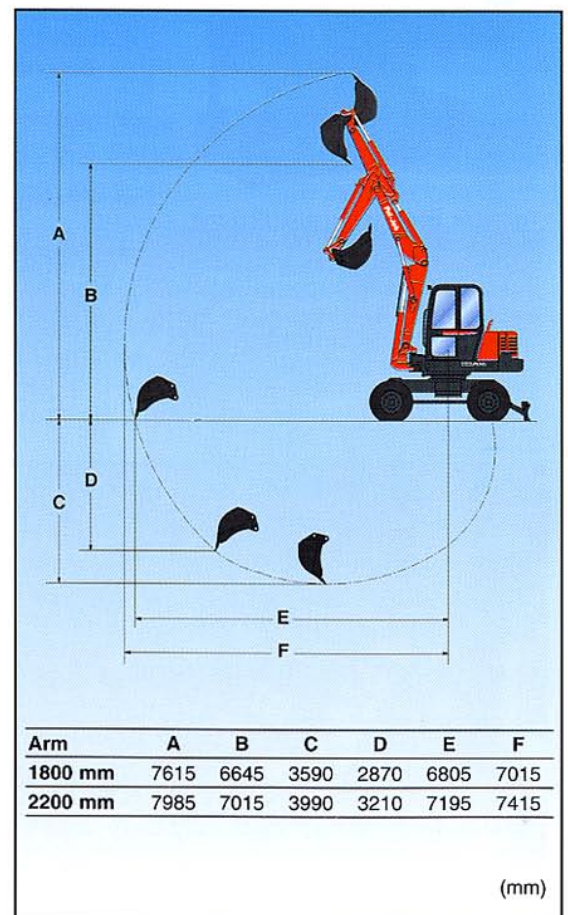
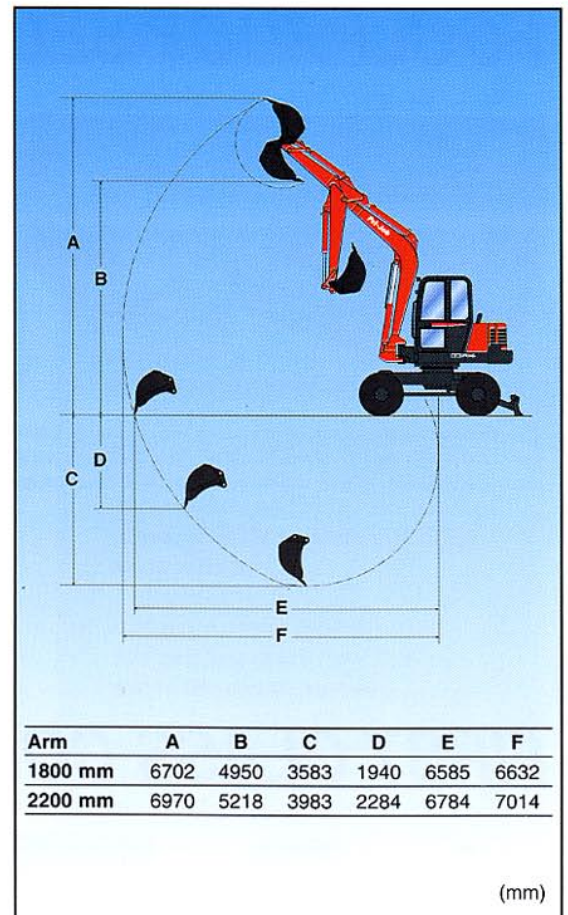

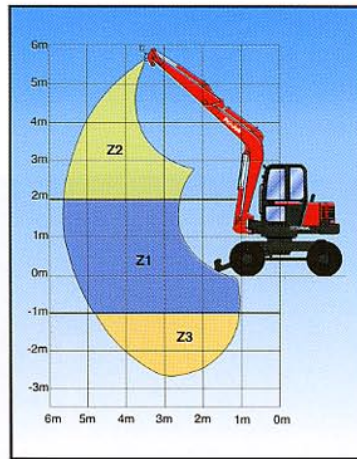
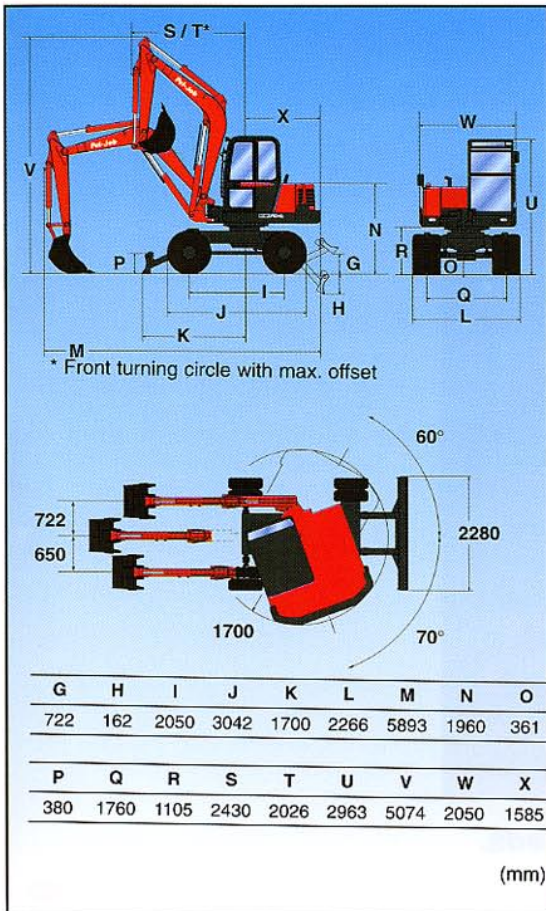

EB 706

SINGLE-PIECE BOOM

LIFTING CAPACITIES

These values are given for a machine without a bucket or quick connecting link, and equipped with standard tyres for all the height considered on each zone Z.

The lifting capacity represents 75% of the tipping load or 87% of the hydraulic limit.



Lifting capacity in rear longitudinal position and resting on the blade or the stabilizers.

Lifting capacity in total rotation over 360° with the blade or the stabilizers raised.

Horizontal Range		2,5 m	3 m	4 m	5 m	max. 5,6 m
1800 mm		Z2 2800*	1660*	1220*	1280*	
		Z1 2620	2730*	1900*	1610*	1090*
		Z3 3130*	2430*	2390*		
1800 mm		Z2 2610	1660*	1180	930	
		Z1 2320	1780*	1210	900	770
		Z3 2380	1810	1220		

Horizontal Range		2,5 m	3 m	4 m	5 m	max. 6,0 m
2200 mm		Z2 2970*	1680*	1060*	1130*	
		Z1 2970*	2240*	1670*	1450*	840*
		Z3 3820*	3010	1950*	1450*	
2200 mm		Z2 2540	1680*	1060*	920	
		Z1 2280	1750	1180	870	840*
		Z3 2310	1760	1180	880	

* Hydraulic limit

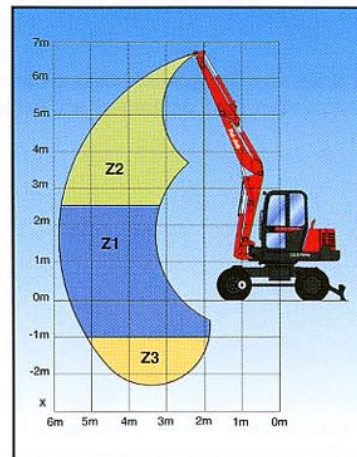
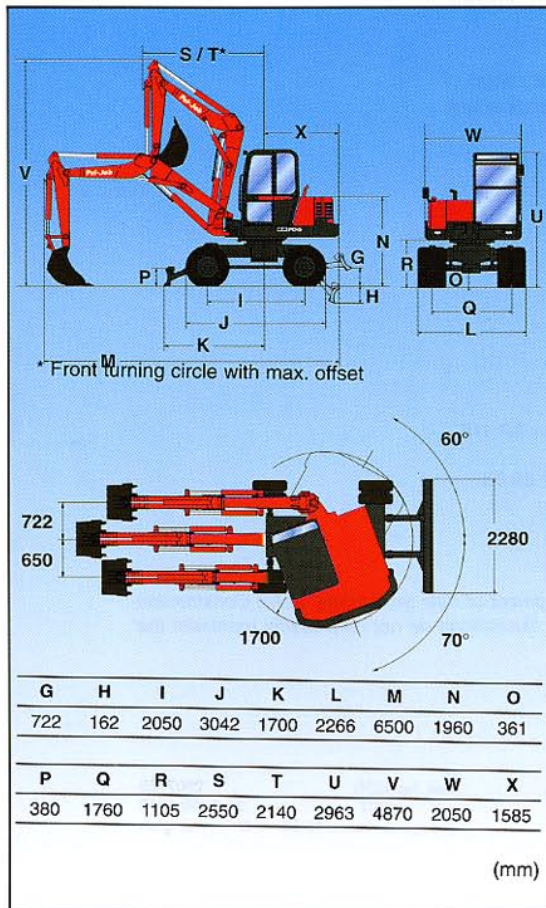

EB 706

ARTICULATED BOOM

LIFTING CAPACITIES

These values are given for a machine without a bucket or quick connecting link, and equipped with standard tyres for all the height considered on each zone Z.

The lifting capacity represents 75% of the tipping load or 87% of the hydraulic limit.



Lifting capacity in rear longitudinal position and resting on the blade or the stabilizers.

Lifting capacity in total rotation over 360° with the blade or the stabilizers raised.

Horizontal Range		2,5 m	3 m	4 m	5 m	max. 6,0 m
1800 mm		Z2 2090*	1640*	1315*	980*	
		Z1 2390*	1775*	1245*	980*	940*
		Z3 2825*	2000*	1750*	1430*	
1800 mm		Z2 1640*	1640*	1315*	940	
		Z1 2390*	1175*	1185	875	685
		Z3 2425	1815	1195	895	

Horizontal Range		2,5 m	3 m	4 m	5 m	max. 6,4 m
2200 mm		Z2 1910*	1910*	1215*	985*	
		Z1 2395*	1685*	1100*	1020*	725*
		Z3 2700*	2015*	1620*	1245*	
2200 mm		Z2 1910*	1910*	1215*	870	
		Z1 2140	1610	1070	790	565
		Z3 2165	1625	1075	795	

* Hydraulic limit



A technology to suit your needs.

Choosing Volvo Construction Equipment machines means having high quality and high productivity. It also means being assured of the reliability of machines built to take into account the needs of the operator as well as those of the environment. From each range you can choose the machine most suited to your needs, enabling you to improve the profitability of even the most difficult site in complete safety.

Compact & Service Equipment offers a complete range of compact excavators, compact loaders and excavators/loaders.

Ecomat Industrie S.A. - Avenue Charles de Gaulle - BP 119
F - 01303 Belley Cedex
Tél. : +33 (0)4 79 81 15 09 - Fax : +33 (0)4 79 81 39 63

In order to adapt their products continuously to suit the needs of users and the development of new techniques, Volvo Construction Equipment Group reserves the right to change their specifications without notice. The illustrations do not necessarily represent the standard versions of the machines.

**Volvo Construction
Equipment Group**

Ref. No. KON 2907728
CST 21 4 432 1012
Printed in France 10.98 N English