



HC 80 | Hydraulic Crawler Crane 80 t Lifting Capacity



HC 80

HYDRAULIC CRAWLER CRANE

HC 80

HIGHLIGHTS

- ▶ 80 (73 mt) tons maximum lifting capacity
- ▶ 200 ft (61 m) maximum length of main boom
- ▶ 170 + 60 ft (52 + 18 m) maximum boom and jib and jib
- ▶ 240 ft (73 m) max. boom and luffing jib length
- ▶ Power up/down and freefall on main, auxiliary and optional third drum
- ▶ Quiet, spacious operator's cab
- ▶ Excellent visibility
- ▶ Two speed travel
- ▶ Superior transportability – 88,000 lb (39 917 kg) transport weight includes side-frames and boom inner

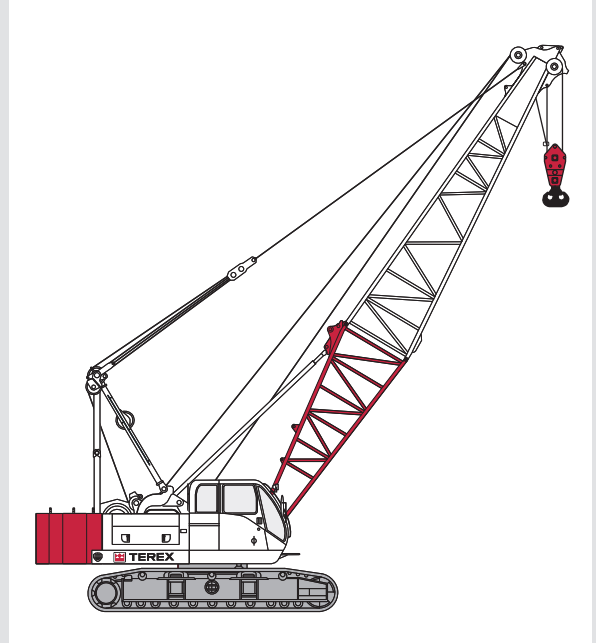

CONTENTS

Page:

Specifications

| | |
|------------------|---|
| Dimensions | 4 |
|------------------|---|

1

Main boom

| | |
|---|----|
| Range Diagram, 47HI Boom | 6 |
| With 47HI Offset Tip Boom and 58,100 Pound Counterweight | 7 |
| Range Diagram, 46HI Boom | 11 |
| With 46HI Angle Boom, 4 Sheave Tip and 58,100 Pound Counterweight | 12 |

2

Jib

| | |
|---|----|
| Range diagram, 47HI Boom, #9HL Jib | 16 |
| With 47HI Boom, #9HL Jib and 58,100 Pound Counterweight | 17 |
| Range diagram, 46 HI Boom, #9 Angle Jib | 21 |
| With 46HI Boom, #9 Angle Jib and 58,100 Pound Counterweight | 22 |

3

Technical description

| | |
|-------------------------------|----|
| Hydraulic Crawler Crane | 28 |
|-------------------------------|----|

4

Transport example for HC 80

| | |
|-------|----|
| | 29 |
|-------|----|

5

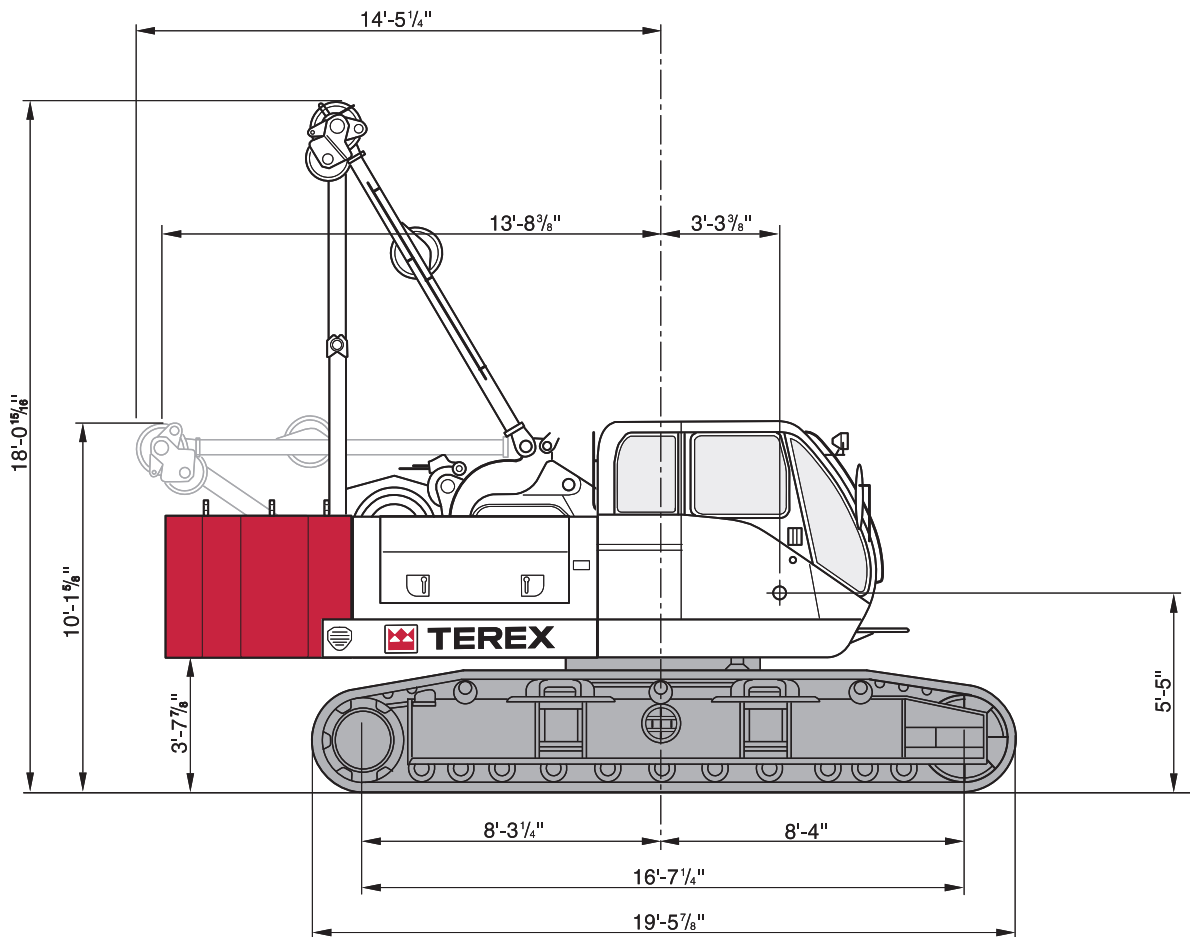
DIMENSIONS

DIMENSIONS

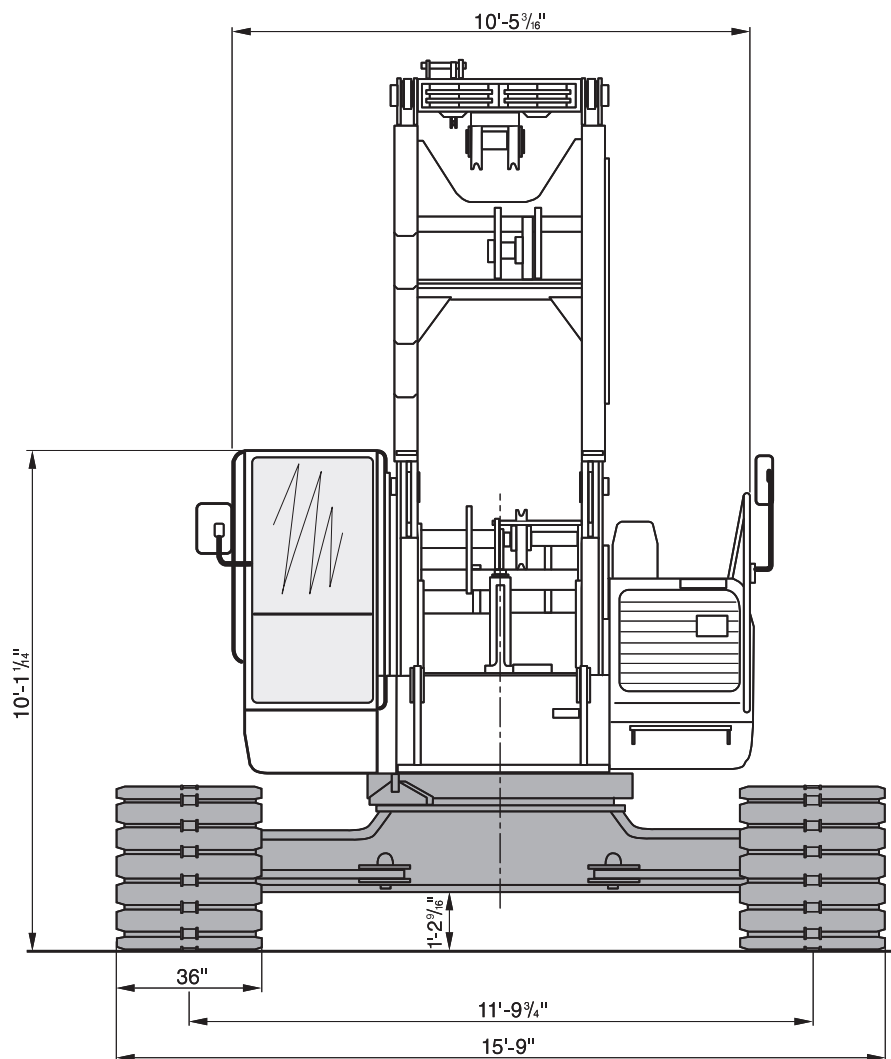

RANGE DIAGRAM, 47HI BOOM

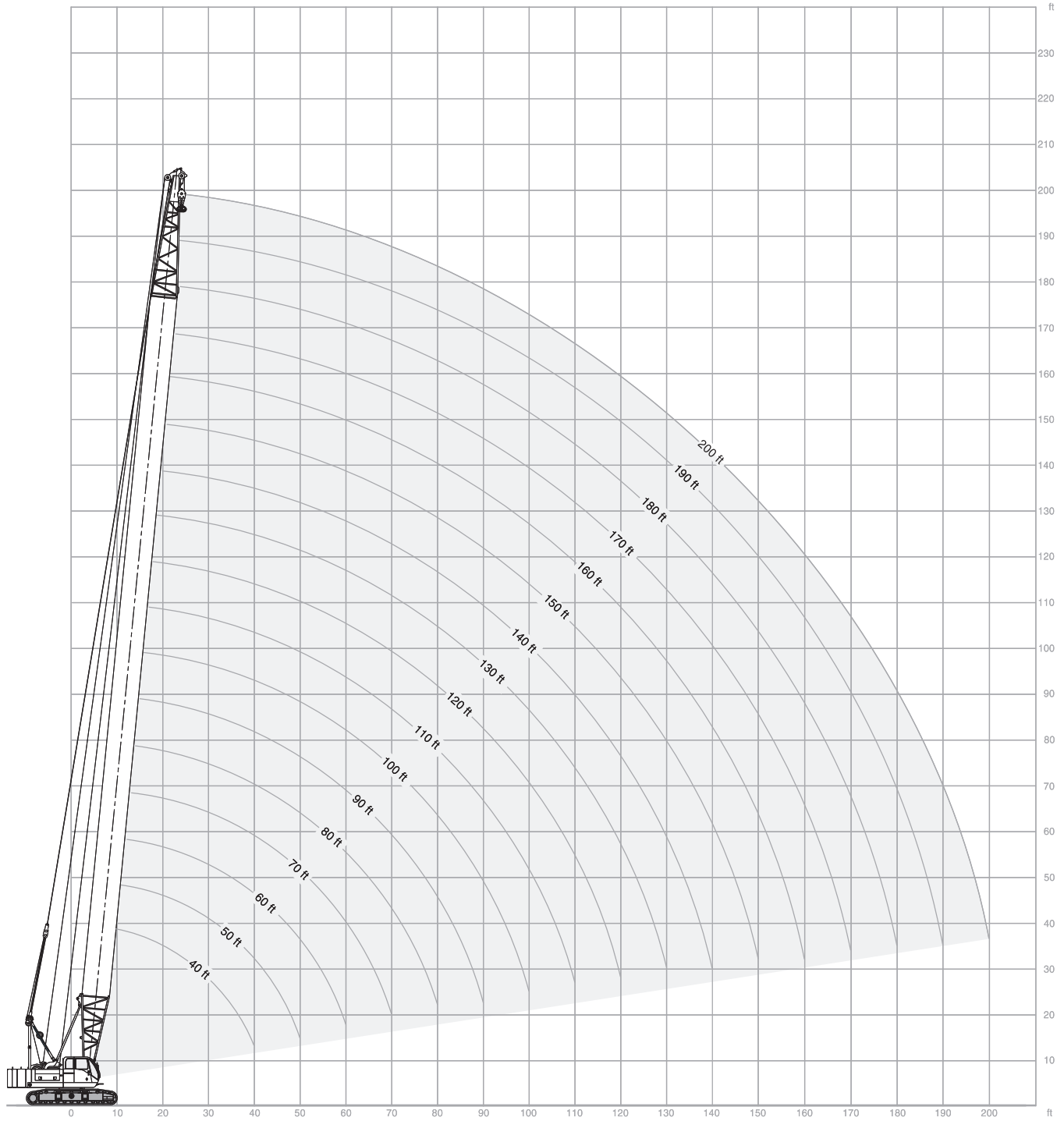

WITH 47HI OFFSET TIP BOOM

 58,100 lb

360°

ANSI B 30.5

40' (12.2 m) Boom length

| Radius (Feet) | Boom Angle (Degrees) | Side Frames Extended (Pounds) | From Boom Pt. to Ground (Feet) |
|---------------|----------------------|-------------------------------|--------------------------------|
| 11 | 80.5 | 160,000 * | 45 |
| 12 | 79.0 | 160,000 * | 45 |
| 15 | 74.6 | 141,480 | 44 |
| 20 | 67.0 | 87,810 | 42 |
| 25 | 58.8 | 63,360 | 40 |
| 30 | 49.9 | 49,350 | 36 |
| 35 | 39.5 | 40,320 | 31 |
| 40 | 25.8 | 33,970 | 23 |

50' (15.2 m) Boom length

| Radius (Feet) | Boom Angle (Degrees) | Side Frames Extended (Pounds) | From Boom Pt. to Ground (Feet) |
|---------------|----------------------|-------------------------------|--------------------------------|
| 13 | 80.1 | 160,000 * | 55 |
| 15 | 77.8 | 141,440 | 54 |
| 20 | 71.8 | 87,750 | 53 |
| 25 | 65.6 | 63,280 | 51 |
| 30 | 59.1 | 49,250 | 48 |
| 35 | 52.0 | 40,220 | 45 |
| 40 | 44.2 | 33,860 | 40 |
| 50 | 22.9 | 25,540 | 25 |

60' (18.3 m) Boom length

| Radius (Feet) | Boom Angle (Degrees) | Side Frames Extended (Pounds) | From Boom Pt. to Ground (Feet) |
|---------------|----------------------|-------------------------------|--------------------------------|
| 14 | 80.8 | 145,370 * | 65 |
| 15 | 79.8 | 141,380 | 64 |
| 20 | 74.9 | 87,660 | 63 |
| 25 | 69.9 | 63,170 | 62 |
| 30 | 64.7 | 49,120 | 60 |
| 35 | 59.2 | 40,100 | 57 |
| 40 | 53.4 | 33,730 | 54 |
| 50 | 40.2 | 25,400 | 44 |
| 60 | 20.8 | 20,230 | 27 |

70' (21.3 m) Boom length

| Radius (Feet) | Boom Angle (Degrees) | Side Frames Extended (Pounds) | From Boom Pt. to Ground (Feet) |
|---------------|----------------------|-------------------------------|--------------------------------|
| 16 | 80.5 | 125,040 * | 74 |
| 20 | 77.1 | 87,590 | 74 |
| 25 | 72.9 | 63,090 | 72 |
| 30 | 68.5 | 49,040 | 71 |
| 35 | 64.0 | 40,020 | 68 |
| 40 | 59.3 | 33,640 | 66 |
| 50 | 49.2 | 25,310 | 58 |
| 60 | 37.0 | 20,150 | 48 |
| 70 | 19.2 | 16,580 | 28 |

80' (24.4 m) Boom length

| Radius (Feet) | Boom Angle (Degrees) | Side Frames Extended (Pounds) | From Boom Pt. to Ground (Feet) |
|---------------|----------------------|-------------------------------|--------------------------------|
| 17 | 80.9 | 109,250 * | 84 |
| 20 | 78.8 | 87,470 | 84 |
| 25 | 75.1 | 62,960 | 83 |
| 30 | 71.3 | 48,880 | 81 |
| 35 | 67.5 | 39,870 | 79 |
| 40 | 63.5 | 33,480 | 77 |
| 50 | 55.1 | 25,140 | 71 |
| 60 | 45.8 | 20,000 | 63 |
| 70 | 34.5 | 16,430 | 51 |
| 80 | 17.9 | 13,830 | 30 |

90' (27.4 m) Boom length

| Radius (Feet) | Boom Angle (Degrees) | Side Frames Extended (Pounds) | From Boom Pt. to Ground (Feet) |
|---------------|----------------------|-------------------------------|--------------------------------|
| 19 | 80.7 | 94,540 | 94 |
| 20 | 80.0 | 87,330 | 94 |
| 25 | 76.8 | 62,810 | 93 |
| 30 | 73.5 | 48,720 | 92 |
| 35 | 70.1 | 39,720 | 90 |
| 40 | 66.7 | 33,320 | 88 |
| 50 | 59.5 | 24,970 | 83 |
| 60 | 51.7 | 19,840 | 76 |
| 70 | 43.0 | 16,260 | 67 |
| 80 | 32.5 | 13,660 | 54 |
| 90 | 16.9 | 11,690 | 32 |

100' (30.5 m) Boom length

| Radius (Feet) | Boom Angle (Degrees) | Side Frames Extended (Pounds) | From Boom Pt. to Ground (Feet) |
|---------------|----------------------|-------------------------------|--------------------------------|
| 21 | 80.4 | 80,910 | 104 |
| 25 | 78.1 | 62,690 | 103 |
| 30 | 75.2 | 48,580 | 102 |
| 35 | 72.2 | 39,590 | 101 |
| 40 | 69.1 | 33,190 | 99 |
| 50 | 62.8 | 24,840 | 94 |
| 60 | 56.1 | 19,720 | 88 |
| 70 | 48.9 | 16,130 | 81 |
| 80 | 40.7 | 13,540 | 71 |
| 90 | 30.7 | 11,560 | 56 |
| 100 | 16.0 | 10,010 | 33 |

110' (33.5 m) Boom length

| Radius (Feet) | Boom Angle (Degrees) | Side Frames Extended (Pounds) | From Boom Pt. to Ground (Feet) |
|---------------|----------------------|-------------------------------|--------------------------------|
| 22 | 80.8 | 72,040 * | 114 |
| 25 | 79.2 | 62,530 | 113 |
| 30 | 76.5 | 48,420 | 112 |
| 35 | 73.8 | 39,430 | 111 |
| 40 | 71.1 | 33,020 | 109 |
| 50 | 65.5 | 24,650 | 105 |
| 60 | 59.6 | 19,560 | 100 |
| 70 | 53.3 | 15,970 | 94 |
| 80 | 46.4 | 13,360 | 85 |
| 90 | 38.7 | 11,380 | 74 |
| 100 | 29.2 | 9,840 | 59 |
| 110 | 15.2 | 8,590 | 34 |

KEY

 Counterweight

CB Central ballast

WITH 47HI OFFSET TIP BOOM
 **58,100 lb**
360°
ANSI B 30.5
120' (36.6 m) Boom length

| Radius (Feet) | Boom Angle (Degrees) | Side Frames Extended (Pounds) | From Boom Pt. to Ground (Feet) |
|---------------|----------------------|-------------------------------|--------------------------------|
| 24 | 80.6 | 60,160 * | 124 |
| 25 | 80.1 | 60,160 * | 124 |
| 30 | 77.7 | 48,260 | 123 |
| 35 | 75.2 | 39,260 | 121 |
| 40 | 72.7 | 32,850 | 120 |
| 50 | 67.6 | 24,470 | 116 |
| 60 | 62.3 | 19,390 | 112 |
| 70 | 56.8 | 15,800 | 106 |
| 80 | 50.8 | 13,190 | 98 |
| 90 | 44.3 | 11,210 | 89 |
| 100 | 37.0 | 9,660 | 78 |
| 110 | 28.0 | 8,410 | 62 |
| 120 | 14.5 | 7,390 | 36 |

130' (39.6 m) Boom length

| | | | |
|-----|------|----------|-----|
| 25 | 80.9 | 50,970 * | 134 |
| 30 | 78.6 | 48,100 | 133 |
| 35 | 76.4 | 39,120 | 132 |
| 40 | 74.1 | 32,700 | 130 |
| 50 | 69.4 | 24,320 | 127 |
| 60 | 64.7 | 19,240 | 123 |
| 70 | 59.6 | 15,650 | 118 |
| 80 | 54.4 | 13,040 | 111 |
| 90 | 48.7 | 11,060 | 103 |
| 100 | 42.5 | 9,510 | 93 |
| 110 | 35.4 | 8,250 | 81 |
| 120 | 26.8 | 7,230 | 64 |
| 130 | 13.9 | 6,380 | 37 |

140' (42.7 m) Boom length

| | | | |
|-----|------|----------|-----|
| 27 | 80.7 | 42,380 * | 144 |
| 30 | 79.5 | 42,370 * | 143 |
| 35 | 77.4 | 38,950 | 142 |
| 40 | 75.3 | 32,530 | 141 |
| 50 | 71.0 | 24,140 | 138 |
| 60 | 66.6 | 19,070 | 134 |
| 70 | 62.0 | 15,480 | 129 |
| 80 | 57.3 | 12,860 | 123 |
| 90 | 52.2 | 10,880 | 116 |
| 100 | 46.8 | 9,330 | 108 |
| 110 | 40.9 | 8,070 | 97 |
| 120 | 34.1 | 7,040 | 84 |
| 130 | 25.8 | 6,180 | 66 |
| 140 | 13.4 | 5,470 | 38 |

150' (45.7 m) Boom length

| Radius (Feet) | Boom Angle (Degrees) | Side Frames Extended (Pounds) | From Boom Pt. to Ground (Feet) |
|---------------|----------------------|-------------------------------|--------------------------------|
| 28 | 80.9 | 36,630 * | 154 |
| 30 | 80.2 | 36,540 * | 153 |
| 35 | 78.2 | 36,070 * | 152 |
| 40 | 76.3 | 32,360 | 151 |
| 50 | 72.3 | 23,960 | 148 |
| 60 | 68.2 | 18,900 | 145 |
| 70 | 64.0 | 15,310 | 140 |
| 80 | 59.7 | 12,690 | 135 |
| 90 | 55.1 | 10,710 | 128 |
| 100 | 50.3 | 9,150 | 121 |
| 110 | 45.1 | 7,890 | 112 |
| 120 | 39.4 | 6,860 | 101 |
| 130 | 32.9 | 6,000 | 87 |
| 140 | 24.9 | 5,270 | 69 |
| 150 | 12.9 | 4,650 | 39 |

160' (48.8 m) Boom length

| | | | |
|-----|------|----------|-----|
| 30 | 80.8 | 31,770 * | 163 |
| 35 | 79.0 | 31,370 * | 162 |
| 40 | 77.1 | 30,790 * | 161 |
| 50 | 73.4 | 23,800 | 159 |
| 60 | 69.7 | 18,750 | 155 |
| 70 | 65.8 | 15,150 | 151 |
| 80 | 61.8 | 12,530 | 146 |
| 90 | 57.6 | 10,550 | 141 |
| 100 | 53.2 | 8,990 | 134 |
| 110 | 48.6 | 7,730 | 125 |
| 120 | 43.6 | 6,690 | 116 |
| 130 | 38.1 | 5,830 | 104 |
| 140 | 31.8 | 5,100 | 90 |
| 150 | 24.1 | 4,480 | 71 |
| 160 | 12.5 | 3,950 | 40 |

170' (51.8 m) Boom length

| | | | |
|-----|------|----------|-----|
| 31 | 81.0 | 27,710 * | 173 |
| 35 | 79.6 | 27,340 * | 173 |
| 40 | 77.9 | 26,810 * | 172 |
| 50 | 74.4 | 23,610 | 169 |
| 60 | 70.9 | 18,580 | 166 |
| 70 | 67.3 | 14,980 | 162 |
| 80 | 63.6 | 12,360 | 158 |
| 90 | 59.7 | 10,360 | 152 |
| 100 | 55.7 | 8,800 | 146 |
| 110 | 51.5 | 7,540 | 139 |
| 120 | 47.1 | 6,510 | 130 |
| 130 | 42.2 | 5,650 | 120 |
| 140 | 36.9 | 4,920 | 108 |
| 150 | 30.8 | 4,290 | 93 |
| 160 | 23.4 | 3,750 | 73 |
| 170 | 12.1 | 3,290 | 41 |

WITH 47HI OFFSET TIP BOOM

 **58,100 lb**

360°

ANSI B 30.5

| 180' (54.9 m) Boom length | | | |
|----------------------------------|----------------------|-------------------------------|--------------------------------|
| Radius (Feet) | Boom Angle (Degrees) | Side Frames Extended (Pounds) | From Boom Pt. to Ground (Feet) |
| 33 | 80.9 | 24,240 * | 183 |
| 35 | 80.2 | 24,110 * | 183 |
| 40 | 78.6 | 23,210 * | 182 |
| 50 | 75.3 | 20,080 * | 180 |
| 60 | 72.0 | 18,410 | 177 |
| 70 | 68.6 | 14,800 | 173 |
| 80 | 65.1 | 12,180 | 169 |
| 90 | 61.6 | 10,190 | 164 |
| 100 | 57.9 | 8,630 | 158 |
| 110 | 54.0 | 7,360 | 151 |
| 120 | 50.0 | 6,330 | 143 |
| 130 | 45.7 | 5,460 | 134 |
| 140 | 41.0 | 4,720 | 123 |
| 150 | 35.8 | 4,100 | 111 |
| 160 | 29.9 | 3,550 | 95 |
| 170 | 22.7 | 3,080 | 75 |
| 180 | 11.8 | 2,690 | 42 |

| 200' (61.0 m) Boom length | | | |
|----------------------------------|----------------------|-------------------------------|--------------------------------|
| Radius (Feet) | Boom Angle (Degrees) | Side Frames Extended (Pounds) | From Boom Pt. to Ground (Feet) |
| 36 | 80.9 | 16,750 * | 203 |
| 40 | 79.7 | 16,230 * | 202 |
| 50 | 76.8 | 15,000 * | 200 |
| 60 | 73.8 | 13,800 * | 198 |
| 70 | 70.8 | 12,770 * | 194 |
| 80 | 67.8 | 11,840 | 191 |
| 90 | 64.6 | 9,840 | 186 |
| 100 | 61.4 | 8,270 | 181 |
| 110 | 58.1 | 7,010 | 175 |
| 120 | 54.6 | 5,970 | 169 |
| 130 | 51.0 | 5,100 | 161 |
| 140 | 47.2 | 4,370 | 152 |
| 150 | 43.2 | 3,740 | 142 |
| 160 | 38.8 | 3,190 | 131 |
| 170 | 33.9 | 2,710 | 117 |
| 180 | 28.4 | 2,300 | 100 |
| 190 | 21.5 | 1,940 | 79 |
| 200 | 11.2 | 1,560 * | 44 |

| 190' (57.9 m) Boom length | | | |
|----------------------------------|----------------------|-------------------------------|--------------------------------|
| Radius (Feet) | Boom Angle (Degrees) | Side Frames Extended (Pounds) | From Boom Pt. to Ground (Feet) |
| 35 | 80.7 | 19,320 * | 193 |
| 40 | 79.2 | 18,660 * | 192 |
| 50 | 76.1 | 17,360 * | 190 |
| 60 | 73.0 | 16,110 * | 187 |
| 70 | 69.8 | 14,640 | 184 |
| 80 | 66.5 | 12,010 | 180 |
| 90 | 63.2 | 10,020 | 175 |
| 100 | 59.8 | 8,460 | 170 |
| 110 | 56.2 | 7,200 | 163 |
| 120 | 52.5 | 6,160 | 156 |
| 130 | 48.5 | 5,290 | 148 |
| 140 | 44.4 | 4,550 | 138 |
| 150 | 39.8 | 3,930 | 127 |
| 160 | 34.8 | 3,390 | 114 |
| 170 | 29.1 | 2,910 | 98 |
| 180 | 22.1 | 2,500 | 77 |
| 190 | 11.5 | 2,150 | 43 |

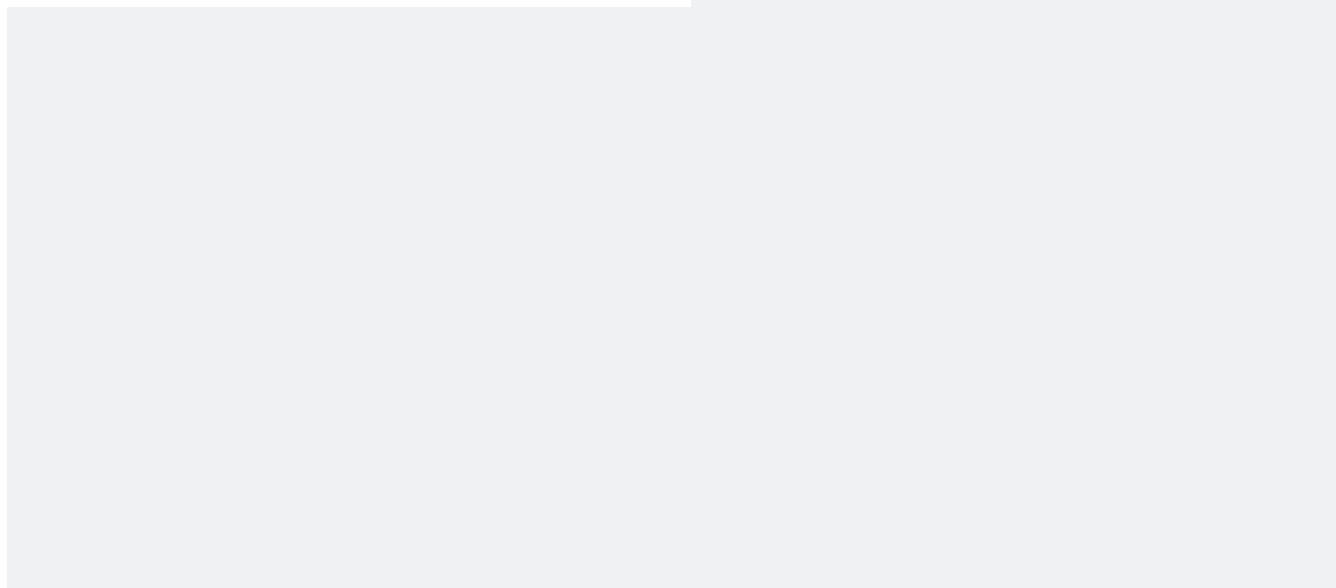

NOTES TO LIFTING CAPACITY

Warning

This rating chart is invalid if the crane has been modified or altered by use of other than GENUINE AMERICAN PARTS as such modifications or alterations may affect its capacity or safe operation. See American Crane Corporation Service Bulliten #259.

Ratings in this chart are in POUNDS and do not exceed the percentage of tipping specified for this crane by ANSI B30.5. All ratings require that the crane be standing level on a firm uniformly supporting surface.

Do not lift loads in excess of those shown on this chart. Lifting loads in excess of those shown or operation not in accordance with good operating practice, including limitations shown on page 3499 of Operator's Manual, can cause tipping, structural damage or catastrophic failure.

Asterisk (*) areas on this chart indicate ratings which are limited by strength of material or factors other than stability (tipping).

„RADIUS IN FEET“ is the horizontal distance at ground level from the crane centerline of rotation to a vertical line through the center of gravity of the suspended load.

When using the main boom fall with jib in place, the main fall ratings must be reduced by the jib effective weight shown on the jib rating chart plus twice the weight of all suspended blocks, slings, rope, etc., at the jib fall. See Appendix A.

When using the main boom fall with boom tip extension in place, the main fall ratings must be reduced by the weight of the boom tip extension plus twice the weight of all suspended blocks, slings, rope, etc., at the boom tip extension fall. See Appendix A.

Blocks, slings, buckets and other load carrying devices are considered part of the load. The weight of standard hoisting ropes for the rating at a given radius has been calculated as part of the boom point load and need not be considered in determining net allowable loads. See Appendix A.

This chart was developed exclusively for use with a boom only. Under no circumstances are these ratings to be interpreted for use with a jib.

Ratings shown on this chart make no allowance for such factors as out of plumb loads, wind, poor soil conditions, improper inflation of rubber tires and dynamic effects due to excessive operating speeds. The user (operator) must exercise judgement to make allowance for these conditions. See page 3499 of Operator's Manual for detailed information.

No account is taken of the wind force on the load. This effect, which can be substantial for loads with large surface areas, must be considered by the user. In any wind it is strongly recommended that taglines be used to control the load.

BOOM HOIST LINE is 14 parts of 5/8 inch diameter EIPS wire rope with a minimum breaking strength of 41,200 pounds.

PENDANT SUSPENSION LINE is 2 parts of 1-1/4 inch diameter MONOLAY wire rope with a minimum breaking strength of 172,800 pounds.

MAIN LOAD LINE is 7/8 inch diameter EIPS wire rope with a minimum breaking strength of 79,600 pounds.

ERECTION

Erection is with the A-Frame fully raised. Erection „OVER THE END“ is with the boom over the idler end. Erection „OVER THE SIDE“ is with the boom 90° to the sideframes and with the side frames extended. Blocks, slings and other load carrying devices must be on the ground during erection.

| MAXIMUM BOOM & JIB SELF-ERECTION DATA | | |
|---------------------------------------|------------------------------|-------------------|
| | OVER THE END & OVER THE SIDE | |
| | BOOM LENGTH (FEET) | JIB LENGTH (FEET) |
| #7HL JIB | 200 170 | 0 60 |
| #9HL JIB | 200 170 | 0 60 |

| 47HI BOOM COMPOSITION CHART | | | | | |
|-----------------------------|----------------|----------------|----------------|----------------|-----------------------|
| BOOM LENGTH (FEET) | BOOM SECTIONS | | | | |
| | 20' 47HI INNER | 10' 47H CENTER | 20' 47H CENTER | 30' 47H CENTER | 20' 47H or 47HI OUTER |
| 40 | 1 | 0 | 0 | 0 | 1 |
| 50 | 1 | 1 | 0 | 0 | 1 |
| 60 | 1 | 0 | 1 | 0 | 1 |
| 70 | 1 | 0 | 0 | 1 | 1 |
| 80 | 1 | 1 | 0 | 1 | 1 |
| 90 | 1 | 0 | 1 | 1 | 1 |
| 100 | 1 | 0 | 0 | 2 | 1 |
| 110 | 1 | 1 | 0 | 2 | 1 |
| 120 | 1 | 0 | 1 | 2 | 1 |
| 130 | 1 | 0 | 0 | 3 | 1 |
| 140 | 1 | 1 | 0 | 3 | 1 |
| 150 | 1 | 0 | 1 | 3 | 1 |
| 160 | 1 | 0 | 0 | 4 | 1 |
| 170 | 1 | 1 | 0 | 4 | 1 |
| 180 | 1 | 0 | 1 | 4 | 1 |
| 190 | 1 | 0 | 0 | 5 | 1 |
| 200 | 1 | 1 | 0 | 5 | 1 |

| LOAD HOISTING INFORMATION - 7/8 inch diameter EIPS wire rope | | | |
|--|-----------------------|----------------------------------|---------------|
| MAXIMUM LIFTING CAPACITY - LBS. | MINIMUM PARTS OF LINE | MAXIMUM HOISTING DISTANCE - FEET | |
| | | MAIN - (RIGHT) | AUX. - (LEFT) |
| 160,000 | 8 | 73 | 73 |
| 159,180 | 7 | 84 | 84 |
| 136,440 | 6 | 98 | 98 |
| 113,700 | 5 | 117 | 117 |
| 90,960 | 4 | 147 | 147 |
| 68,220 | 3 | 196 | 196 |
| 45,480 | 2 | 294 | 294 |
| 22,740 | 1 | 588 | 588 |

RANGE DIAGRAM, 46HI BOOM

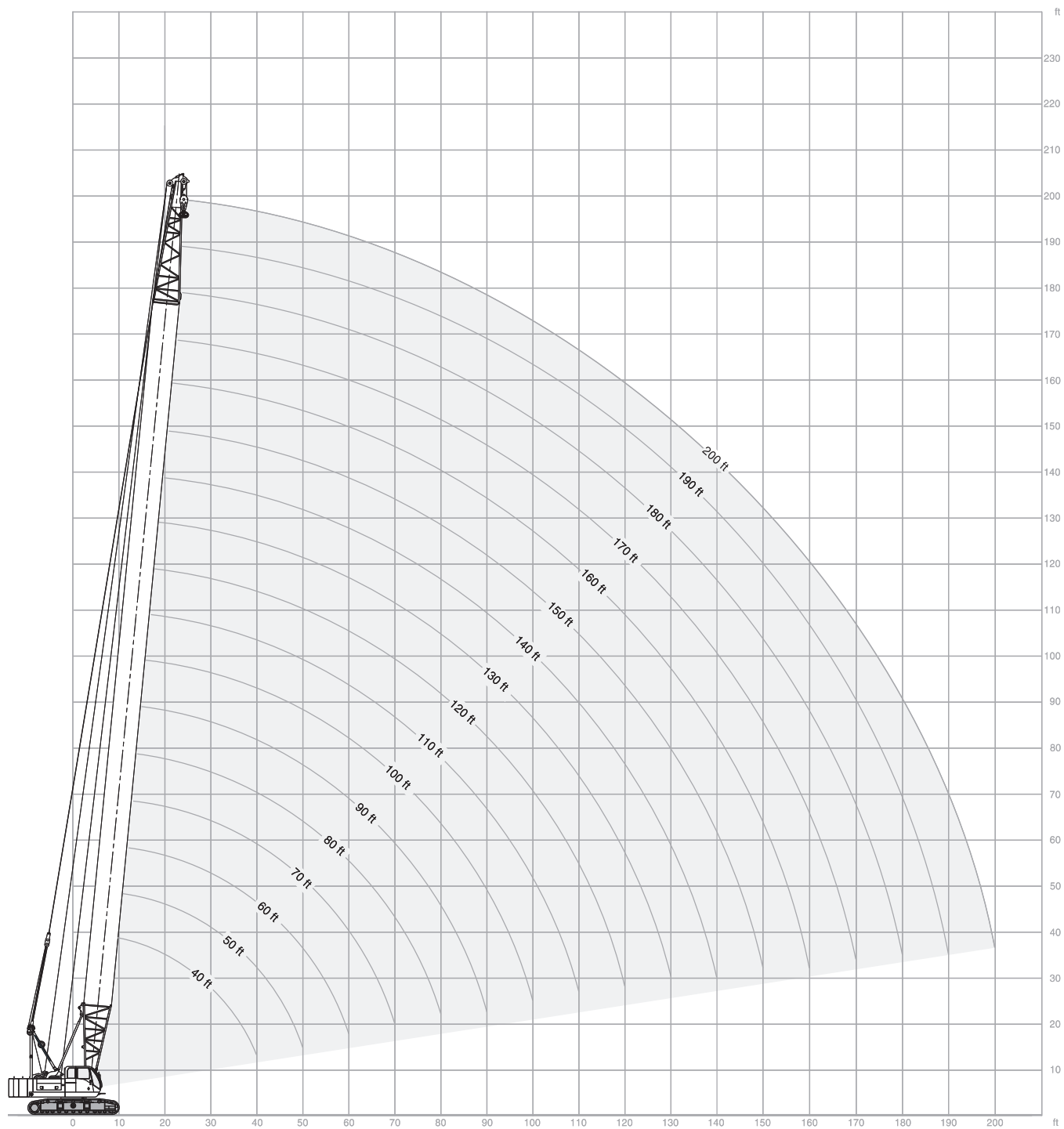

WITH 46HI ANGLE BOOM, 4 SHEAVE TIP
 **58,100 lb**
360°
ANSI B 30.5
40' (12.2 m) Boom length

| Radius (Feet) | Boom Angle (Degrees) | 360 Degree Rating (Pounds) | From Boom Pt. to Ground (Feet) |
|---------------|----------------------|----------------------------|--------------------------------|
| 10 | 80.9 | 160,000* | 45 |
| 12 | 77.9 | 160,000* | 45 |
| 15 | 73.5 | 141,160 | 44 |
| 20 | 65.9 | 87,490 | 42 |
| 25 | 57.7 | 63,040 | 39 |
| 30 | 48.8 | 49,030 | 36 |
| 35 | 38.4 | 40,000 | 30 |
| 40 | 24.7 | 33,650 | 22 |

50' (15.2 m) Boom length

| Radius (Feet) | Boom Angle (Degrees) | 360 Degree Rating (Pounds) | From Boom Pt. to Ground (Feet) |
|---------------|----------------------|----------------------------|--------------------------------|
| 12 | 80.4 | 138,490* | 55 |
| 15 | 76.9 | 128,430* | 54 |
| 20 | 70.9 | 87,390 | 53 |
| 25 | 64.7 | 62,910 | 51 |
| 30 | 58.2 | 48,880 | 48 |
| 35 | 51.2 | 39,850 | 44 |
| 40 | 43.4 | 33,490 | 40 |
| 45 | 34.2 | 28,790 | 34 |
| 50 | 22.0 | 25,180 | 24 |

60' (18.3 m) Boom length

| Radius (Feet) | Boom Angle (Degrees) | 360 Degree Rating (Pounds) | From Boom Pt. to Ground (Feet) |
|---------------|----------------------|----------------------------|--------------------------------|
| 14 | 80.1 | 119,630* | 65 |
| 15 | 79.1 | 117,070* | 64 |
| 20 | 74.2 | 87,280 | 63 |
| 25 | 69.2 | 62,790 | 61 |
| 30 | 64.0 | 48,740 | 59 |
| 35 | 58.5 | 39,710 | 57 |
| 40 | 52.7 | 33,340 | 53 |
| 45 | 46.4 | 28,630 | 49 |
| 50 | 39.4 | 25,020 | 44 |
| 55 | 31.1 | 22,200 | 36 |
| 60 | 20.1 | 19,860 | 26 |

70' (21.3 m) Boom length

| Radius (Feet) | Boom Angle (Degrees) | 360 Degree Rating (Pounds) | From Boom Pt. to Ground (Feet) |
|---------------|----------------------|----------------------------|--------------------------------|
| 15 | 80.7 | 106,350* | 74 |
| 20 | 76.5 | 87,110 | 73 |
| 25 | 72.2 | 62,610 | 72 |
| 30 | 67.9 | 48,550 | 70 |
| 35 | 63.4 | 39,530 | 68 |
| 40 | 58.7 | 33,150 | 65 |
| 45 | 53.8 | 28,440 | 62 |
| 50 | 48.5 | 24,820 | 58 |
| 55 | 42.8 | 22,000 | 53 |
| 60 | 36.4 | 19,660 | 47 |
| 65 | 28.8 | 17,720 | 39 |
| 70 | 18.6 | 16,100 | 28 |

80' (24.4 m) Boom length

| Radius (Feet) | Boom Angle (Degrees) | Side Frames Extended (Pounds) | From Boom Pt. to Ground (Feet) |
|---------------|----------------------|-------------------------------|--------------------------------|
| 17 | 80.4 | 94,370* | 84 |
| 20 | 78.2 | 87,000 | 84 |
| 25 | 74.5 | 62,490 | 83 |
| 30 | 70.8 | 48,410 | 81 |
| 35 | 66.9 | 39,400 | 79 |
| 40 | 63.0 | 33,020 | 77 |
| 45 | 58.9 | 28,300 | 74 |
| 50 | 54.6 | 24,670 | 71 |
| 55 | 50.1 | 21,870 | 67 |
| 60 | 45.2 | 19,540 | 62 |
| 65 | 39.9 | 17,600 | 57 |
| 70 | 34.0 | 15,970 | 50 |
| 75 | 26.9 | 14,570 | 42 |
| 80 | 17.4 | 13,370 | 29 |

90' (27.4 m) Boom length

| Radius (Feet) | Boom Angle (Degrees) | Side Frames Extended (Pounds) | From Boom Pt. to Ground (Feet) |
|---------------|----------------------|-------------------------------|--------------------------------|
| 18 | 80.8 | 84,440* | 94 |
| 20 | 79.5 | 82,260* | 94 |
| 25 | 76.3 | 62,300 | 93 |
| 30 | 73.0 | 48,210 | 91 |
| 35 | 69.6 | 39,200 | 90 |
| 40 | 66.2 | 32,810 | 88 |
| 45 | 62.7 | 28,090 | 85 |
| 50 | 59.0 | 24,460 | 83 |
| 55 | 55.2 | 21,680 | 79 |
| 60 | 51.2 | 19,330 | 76 |
| 65 | 47.0 | 17,390 | 71 |
| 70 | 42.5 | 15,760 | 66 |
| 75 | 37.5 | 14,360 | 60 |
| 80 | 32.0 | 13,160 | 53 |
| 85 | 25.3 | 12,110 | 44 |
| 90 | 16.4 | 11,200 | 31 |

100' (30.5 m) Boom length

| Radius (Feet) | Boom Angle (Degrees) | Side Frames Extended (Pounds) | From Boom Pt. to Ground (Feet) |
|---------------|----------------------|-------------------------------|--------------------------------|
| 20 | 80.6 | 75,930* | 104 |
| 25 | 77.7 | 62,120 | 103 |
| 30 | 74.7 | 48,010 | 102 |
| 35 | 71.7 | 39,020 | 100 |
| 40 | 68.7 | 32,620 | 99 |
| 45 | 65.6 | 27,890 | 96 |
| 50 | 62.4 | 24,260 | 94 |
| 55 | 59.1 | 21,490 | 91 |
| 60 | 55.7 | 19,140 | 88 |
| 65 | 52.2 | 17,200 | 84 |
| 70 | 48.4 | 15,570 | 80 |
| 75 | 44.5 | 14,170 | 75 |
| 80 | 40.2 | 12,960 | 70 |
| 85 | 35.6 | 11,910 | 64 |
| 90 | 30.3 | 10,990 | 56 |
| 95 | 24.0 | 10,170 | 46 |
| 100 | 15.5 | 9,450 | 32 |

WITH 46HI ANGLE BOOM, 4 SHEAVE TIP

58,100 lb

360°

ANSI B 30.5

| 110' (33.5 m) Boom length | | | |
|---------------------------|----------------------|-------------------------------|--------------------------------|
| Radius (Feet) | Boom Angle (Degrees) | Side Frames Extended (Pounds) | From Boom Pt. to Ground (Feet) |
| | 80.9 | 68,930 * | 114 |
| | 78.8 | 61,920 | 113 |
| | 76.1 | 47,800 | 112 |
| | 73.4 | 38,810 | 111 |
| | 70.7 | 32,400 | 109 |
| | 67.9 | 27,680 | 107 |
| | 65.1 | 24,030 | 105 |
| | 62.2 | 21,280 | 103 |
| | 59.2 | 18,940 | 100 |
| | 56.1 | 16,990 | 97 |
| | 52.9 | 15,350 | 93 |
| | 49.6 | 13,950 | 89 |
| | 46.0 | 12,750 | 85 |
| | 42.3 | 11,700 | 79 |
| | 38.3 | 10,760 | 74 |
| | 33.8 | 9,950 | 67 |
| | 28.8 | 9,220 | 58 |
| | 22.9 | 8,570 | 48 |
| | 14.8 | 7,980 | 33 |

| 120' (36.6 m) Boom length | | | |
|---------------------------|----------------------|-------------------------------|--------------------------------|
| Radius (Feet) | Boom Angle (Degrees) | Side Frames Extended (Pounds) | From Boom Pt. to Ground (Feet) |
| 23 | 80.7 | 61,380 * | 124 |
| 25 | 79.7 | 60,000 * | 123 |
| 30 | 77.3 | 47,630 | 122 |
| 35 | 74.8 | 38,640 | 121 |
| 40 | 72.4 | 32,230 | 120 |
| 45 | 69.8 | 27,500 | 118 |
| 50 | 67.3 | 23,850 | 116 |
| 55 | 64.7 | 21,120 | 114 |
| 60 | 62.0 | 18,760 | 111 |
| 65 | 59.2 | 16,820 | 109 |
| 70 | 56.4 | 15,180 | 105 |
| 75 | 53.5 | 13,780 | 102 |
| 80 | 50.5 | 12,570 | 98 |
| 85 | 47.3 | 11,520 | 94 |
| 90 | 44.0 | 10,590 | 89 |
| 95 | 40.4 | 9,770 | 83 |
| 100 | 36.6 | 9,040 | 77 |
| 105 | 32.4 | 8,380 | 70 |
| 110 | 27.6 | 7,790 | 61 |
| 115 | 21.9 | 7,260 | 50 |
| 120 | 14.2 | 6,780 | 35 |

| 130' (39.6 m) Boom length | | | |
|---------------------------|----------------------|-------------------------------|--------------------------------|
| Radius (Feet) | Boom Angle (Degrees) | Side Frames Extended (Pounds) | From Boom Pt. to Ground (Feet) |
| 24 | 81.0 | 55,570 * | 134 |
| 25 | 80.6 | 55,210 * | 134 |
| 30 | 78.3 | 47,410 | 133 |
| 35 | 76.0 | 38,430 | 132 |
| 40 | 73.8 | 32,020 | 130 |
| 45 | 71.4 | 27,280 | 129 |
| 50 | 69.1 | 23,630 | 127 |
| 55 | 66.7 | 20,900 | 125 |
| 60 | 64.3 | 18,560 | 123 |
| 65 | 61.8 | 16,610 | 120 |
| 70 | 59.3 | 14,960 | 117 |
| 75 | 56.7 | 13,570 | 114 |
| 80 | 54.0 | 12,350 | 111 |
| 85 | 51.3 | 11,300 | 107 |
| 90 | 48.4 | 10,370 | 103 |
| 95 | 45.3 | 9,550 | 98 |
| 100 | 42.2 | 8,820 | 93 |
| 105 | 38.8 | 8,160 | 87 |
| 110 | 35.1 | 7,570 | 80 |
| 115 | 31.1 | 7,030 | 72 |
| 120 | 26.5 | 6,540 | 63 |
| 125 | 21.0 | 6,100 | 52 |
| 130 | 13.6 | 5,700 | 36 |

| 140' (42.7 m) Boom length | | | |
|---------------------------|----------------------|-------------------------------|--------------------------------|
| Radius (Feet) | Boom Angle (Degrees) | Side Frames Extended (Pounds) | From Boom Pt. to Ground (Feet) |
| 26 | 80.8 | 49,960 * | 144 |
| 30 | 79.2 | 47,210 | 143 |
| 35 | 77.1 | 38,230 | 142 |
| 40 | 74.9 | 31,810 | 141 |
| 45 | 72.8 | 27,070 | 139 |
| 50 | 70.7 | 23,420 | 138 |
| 55 | 68.5 | 20,710 | 136 |
| 60 | 66.3 | 18,350 | 134 |
| 65 | 64.0 | 16,400 | 131 |
| 70 | 61.7 | 14,760 | 129 |
| 75 | 59.4 | 13,360 | 126 |
| 80 | 57.0 | 12,140 | 123 |
| 85 | 54.5 | 11,090 | 119 |
| 90 | 51.9 | 10,170 | 116 |
| 95 | 49.3 | 9,340 | 111 |
| 100 | 46.5 | 8,610 | 107 |
| 105 | 43.6 | 7,940 | 102 |
| 110 | 40.6 | 7,350 | 96 |
| 115 | 37.3 | 6,820 | 90 |
| 120 | 33.8 | 6,330 | 83 |
| 125 | 29.9 | 5,880 | 75 |
| 130 | 25.5 | 5,480 | 66 |
| 135 | 20.2 | 5,100 | 54 |
| 140 | 13.1 | 4,760 | 37 |



WITH 46HI ANGLE BOOM, 4 SHEAVE TIP

58,100 lb
360°
ANSI B 30.5
150' (45.7 m) Boom length

| Radius (Feet) | Boom Angle (Degrees) | Side Frames Extended (Pounds) | From Boom Pt. to Ground (Feet) |
|---------------|----------------------|-------------------------------|--------------------------------|
| 28 | 80.7 | 43,920* | 153 |
| 30 | 79.9 | 43,170* | 153 |
| 35 | 77.9 | 38,020 | 152 |
| 40 | 76.0 | 31,590 | 151 |
| 45 | 74.0 | 26,850 | 150 |
| 50 | 72.0 | 23,190 | 148 |
| 55 | 70.0 | 20,490 | 146 |
| 60 | 67.9 | 18,130 | 144 |
| 65 | 65.9 | 16,190 | 142 |
| 70 | 63.8 | 14,540 | 140 |
| 75 | 61.6 | 13,130 | 137 |
| 80 | 59.4 | 11,930 | 135 |
| 85 | 57.2 | 10,870 | 131 |
| 90 | 54.8 | 9,940 | 128 |
| 95 | 52.5 | 9,110 | 124 |
| 100 | 50.0 | 8,380 | 120 |
| 105 | 47.5 | 7,720 | 116 |
| 110 | 44.8 | 7,130 | 111 |
| 115 | 42.1 | 6,590 | 106 |
| 120 | 39.1 | 6,100 | 100 |
| 125 | 36.0 | 5,650 | 94 |
| 130 | 32.6 | 5,240 | 86 |
| 135 | 28.9 | 4,860 | 78 |
| 140 | 24.6 | 4,510 | 68 |
| 145 | 19.5 | 4,190 | 56 |
| 150 | 12.7 | 3,900 | 38 |

160' (48.8 m) Boom length

| Radius (Feet) | Boom Angle (Degrees) | Side Frames Extended (Pounds) | From Boom Pt. to Ground (Feet) |
|---------------|----------------------|-------------------------------|--------------------------------|
| 29 | 80.9 | 39,530* | 163 |
| 30 | 80.5 | 39,370* | 163 |
| 35 | 78.7 | 37,830 | 162 |
| 40 | 76.9 | 31,410 | 161 |
| 45 | 75.0 | 26,650 | 160 |
| 50 | 73.2 | 22,990 | 159 |
| 55 | 71.3 | 20,310 | 157 |
| 60 | 69.4 | 17,950 | 155 |
| 65 | 67.4 | 16,000 | 153 |
| 70 | 65.5 | 14,350 | 151 |
| 75 | 63.5 | 12,950 | 149 |
| 80 | 61.5 | 11,730 | 146 |
| 85 | 59.4 | 10,680 | 143 |
| 90 | 57.3 | 9,750 | 140 |
| 95 | 55.2 | 8,920 | 137 |
| 100 | 53.0 | 8,190 | 133 |
| 105 | 50.7 | 7,530 | 129 |
| 110 | 48.3 | 6,930 | 125 |
| 115 | 45.9 | 6,390 | 120 |
| 120 | 43.3 | 5,900 | 115 |
| 125 | 40.7 | 5,450 | 110 |
| 130 | 37.8 | 5,040 | 104 |
| 135 | 34.8 | 4,660 | 97 |
| 140 | 31.5 | 4,310 | 89 |
| 145 | 27.9 | 3,990 | 80 |
| 150 | 23.8 | 3,690 | 70 |
| 155 | 18.9 | 3,420 | 57 |
| 160 | 12.3 | 3,160 | 39 |

NOTES TO LIFTING CAPACITY

⚠ Warning

This rating chart is invalid if the crane has been modified or altered by use of other than GENUINE AMERICAN PARTS as such modifications or alterations may affect its capacity or safe operation. See American Crane Corporation Service Bulliten #259.

Ratings in this chart are in POUNDS and do not exceed the percentage of tipping specified for this crane by ANSI B30.5. All ratings require that the crane be standing level on a firm uniformly supporting surface.

Do not lift loads in excess of those shown on this chart. Lifting loads in excess of those shown or operation not in accordance with good operating practice, including limitations shown on page 3499 of Operator's Manual, can cause tipping, structural damage or catastrophic failure.

Asterisk (*) areas on this chart indicate ratings which are limited by strength of material or factors other than stability (tipping).

„RADIUS IN FEET“ is the horizontal distance at ground level from the crane centerline of rotation to a vertical line through the center of gravity of the suspended load.

When using the main boom fall with jib in place, the main fall ratings must be reduced by the jib effective weight shown on the jib rating chart plus twice the weight of all suspended blocks, slings, rope, etc., at the jib fall. See Appendix A.

When using the main boom fall with boom tip extension in place, the main fall ratings must be reduced by the weight of the boom tip extension plus twice the weight of all suspended blocks, slings, rope, etc., at the boom tip extension fall. See Appendix A.

Blocks, slings, buckets and other load carrying devices are considered part of the load. The weight of standard hoisting ropes for the rating at a given radius has been calculated as part of the boom point load and need not be considered in determining net allowable loads. See Appendix A.

This chart was developed exclusively for use with a boom only. Under no circumstances are these ratings to be interpreted for use with a jib.

Ratings shown on this chart make no allowance for such factors as out of plumb loads, wind, poor soil conditions, improper inflation of rubber tires and dynamic effects due to excessive operating speeds. The user (operator) must exercise judgement to make allowance for these conditions. See page 3499 of Operator's Manual for detailed information.

No account is taken of the wind force on the load. This effect, which can be substantial for loads with large surface areas, must be considered by the user. In any wind it is strongly recommended that taglines be used to control the load.

BOOM HOIST LINE – 14 parts of 5/8 inch diameter EIPS wire rope with a minimum breaking strength of 41,200 pounds.

PENDANT SUSPENSION LINE – 2 parts of 1-1/4 inch diameter MONOLAY wire rope with a minimum breaking strength of 172,800 pounds.

MAIN LOAD LINE – 7/8 inch diameter EIPS wire rope with a minimum breaking strength of 79,600 pounds.

ERECTION

Erection is with the A-Frame fully raised. Erection „OVER THE END“ is with the boom over the idler end. Erection „OVER-THE-SIDE“ is with the boom 90° to the sideframes and with the side frames extended. Blocks, slings and other load carrying devices must be on the ground during erection.

| MAXIMUM BOOM & JIB SELF-ERECTION DATA - 46HI BOOM | | |
|---|------------------------------|-------------------|
| JIB | OVER-THE-END & OVER-THE-SIDE | |
| | BOOM LENGTH (FEET) | JIB LENGTH (FEET) |
| #9 | 160 | 50 |

| BOOM COMPOSITION CHART - 46HI BOOM | | | | | | |
|------------------------------------|----------------|----------------|-----------------|-----------------|-----------------|------------------------|
| BOOM LENGTH (FEET) | BOOM SECTIONS | | | | | |
| | 20' 46HI INNER | 5' 46HR CENTER | 10' 46HR CENTER | 20' 46HR CENTER | 40' 46HR CENTER | 20' 46HR or 46HI OUTER |
| 40 | 1 | 0 | 0 | 0 | 0 | 1 |
| 45 | 1 | 1 | 0 | 0 | 0 | 1 |
| 50 | 1 | 0 | 1 | 0 | 0 | 1 |
| 55 | 1 | 1 | 1 | 0 | 0 | 1 |
| 60 | 1 | 0 | 0 | 1 | 0 | 1 |
| 65 | 1 | 1 | 0 | 1 | 0 | 1 |
| 70 | 1 | 0 | 1 | 1 | 0 | 1 |
| 75 | 1 | 1 | 1 | 1 | 0 | 1 |
| 80 | 1 | 0 | 0 | 0 | 1 | 1 |
| 85 | 1 | 1 | 0 | 0 | 1 | 1 |
| 90 | 1 | 0 | 1 | 0 | 1 | 1 |
| 95 | 1 | 1 | 1 | 0 | 1 | 1 |
| 100 | 1 | 0 | 0 | 1 | 1 | 1 |
| 105 | 1 | 1 | 0 | 1 | 1 | 1 |
| 110 | 1 | 0 | 1 | 1 | 1 | 1 |
| 115 | 1 | 1 | 1 | 1 | 1 | 1 |
| 120 | 1 | 0 | 0 | 0 | 2 | 1 |
| 125 | 1 | 1 | 0 | 0 | 2 | 1 |
| 130 | 1 | 0 | 1 | 0 | 2 | 1 |
| 135 | 1 | 1 | 1 | 0 | 2 | 1 |
| 140 | 1 | 0 | 0 | 1 | 2 | 1 |
| 145 | 1 | 1 | 0 | 1 | 2 | 1 |
| 150 | 1 | 0 | 1 | 1 | 2 | 1 |
| 155 | 1 | 1 | 1 | 1 | 2 | 1 |
| 160 | 1 | 0 | 0 | 0 | 3 | 1 |

| LOAD HOISTING INFORMATION - 7/8 inch diameter EIPS wire rope | | | |
|--|-----------------------|----------------------------------|---------------|
| MAXIMUM LIFTING CAPACITY - LBS. | MINIMUM PARTS OF LINE | MAXIMUM HOISTING DISTANCE - FEET | |
| | | MAIN - (RIGHT) | AUX. - (LEFT) |
| 160,000 | 8 | 73 | 73 |
| 159,180 | 7 | 84 | 84 |
| 136,440 | 6 | 96 | 96 |
| 113,700 | 5 | 117 | 117 |
| 90,960 | 4 | 147 | 147 |
| 68,220 | 3 | 196 | 196 |
| 45,480 | 2 | 294 | 294 |
| 22,740 | 1 | 588 | 588 |



RANGE DIAGRAM, 47HI BOOM, #9HL JIB

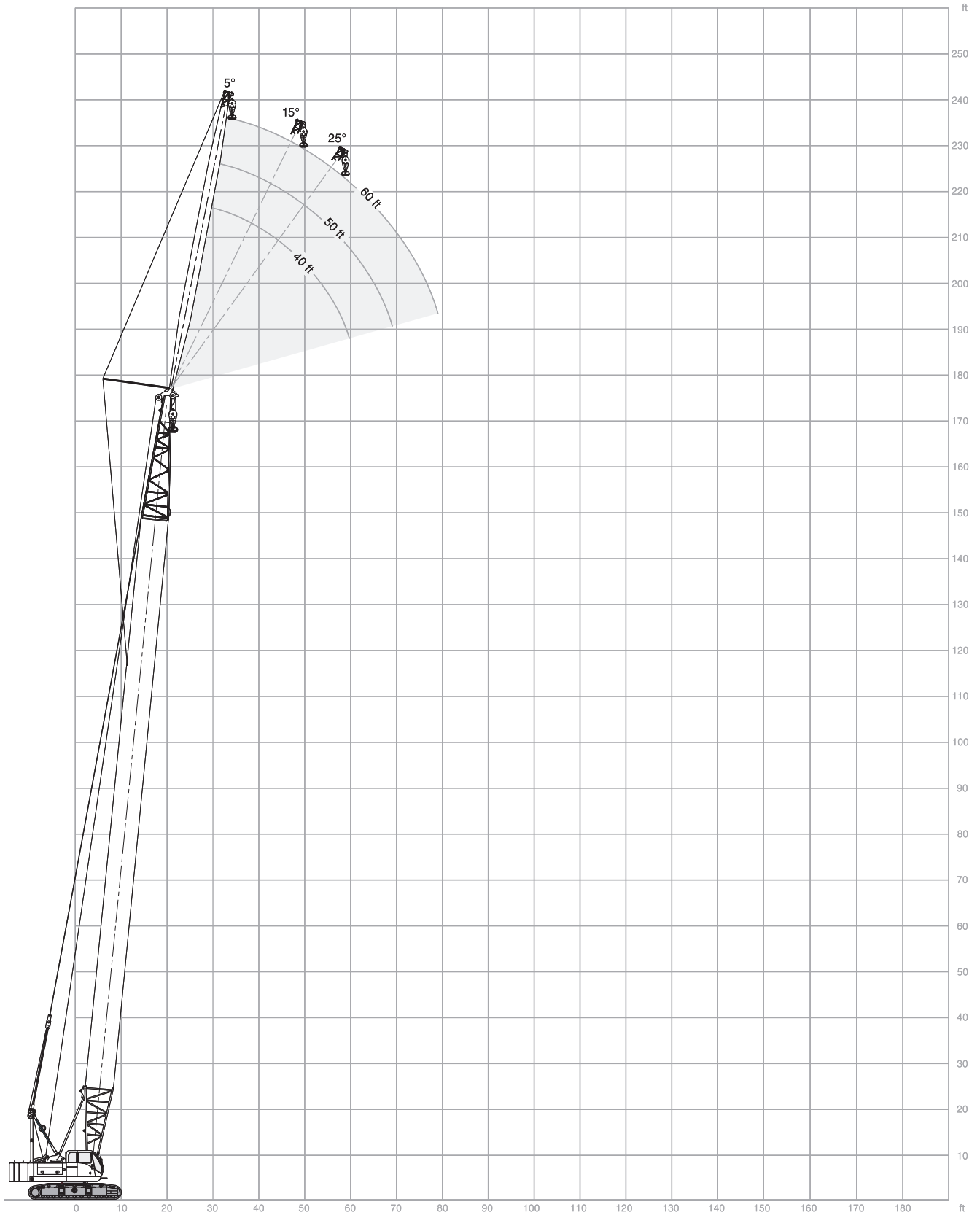

WITH 47HI BOOM, #9HL JIB

58,100 lb

360°

ANSI B 30.5

40' (12.2 m) Jib length

| Boom length | Jib Radius (Feet) | 5.0 Deg offset Boom Angle | 5.0 Deg offset Rating (Pounds) | 15.0 Deg offset Boom Angle | 15.0 Deg offset Rating (Pounds) | 25.0 Deg offset Boom Angle | 25.0 Deg offset Rating (Pounds) |
|----------------------|-------------------|---------------------------|--------------------------------|----------------------------|---------------------------------|----------------------------|---------------------------------|
| | 30 | 80.7 | 22,550* | - | - | - | - |
| | 35 | 78.6 | 22,550* | - | - | - | - |
| | 40 | 76.5 | 22,190* | 79.2 | 20,980* | - | - |
| | 50 | 72.2 | 21,500* | 74.9 | 20,440* | 77.5 | 19,540* |
| 100' (30.5 m) | 60 | 67.9 | 19,650 | 70.5 | 19,650 | 73.0 | 19,100* |
| | 70 | 63.4 | 16,060 | 66.0 | 16,070 | 68.4 | 16,070 |
| | 80 | 58.7 | 13,460 | 61.2 | 13,460 | 63.6 | 13,470 |
| | 90 | 53.7 | 11,490 | 56.2 | 11,490 | 58.4 | 11,500 |
| | 100 | 48.4 | 9,950 | 50.8 | 9,950 | 52.9 | 9,950 |

| | | | | | | | |
|----------------------|-----|------|---------|------|---------|------|---------|
| | 31 | 80.9 | 22,530* | - | - | - | - |
| | 35 | 79.3 | 22,530* | - | - | - | - |
| | 40 | 77.4 | 22,390* | 79.9 | 21,090* | - | - |
| | 50 | 73.5 | 21,670* | 76.0 | 20,540* | 78.3 | 19,630* |
| 110' (33.5 m) | 60 | 69.4 | 19,440 | 71.9 | 19,440 | 74.2 | 19,190* |
| | 70 | 65.3 | 15,860 | 67.7 | 15,860 | 70.0 | 15,860 |
| | 80 | 61.0 | 13,270 | 63.4 | 13,270 | 65.6 | 13,270 |
| | 90 | 56.5 | 11,290 | 58.9 | 11,290 | 61.0 | 11,290 |
| | 100 | 51.7 | 9,740 | 54.1 | 9,740 | 56.1 | 9,740 |
| | 110 | 46.6 | 8,490 | 48.9 | 8,490 | 50.8 | 8,490 |

| | | | | | | | |
|----------------------|-----|------|---------|------|---------|------|---------|
| | 33 | 80.7 | 22,520* | - | - | - | - |
| | 35 | 80.0 | 22,520* | - | - | - | - |
| | 40 | 78.2 | 22,500* | 80.6 | 21,150* | - | - |
| | 50 | 74.5 | 21,850* | 76.9 | 20,630* | 79.1 | 19,480* |
| 120' (36.6 m) | 60 | 70.8 | 19,240 | 73.1 | 19,240 | 75.3 | 19,240 |
| | 70 | 66.9 | 15,660 | 69.2 | 15,660 | 71.4 | 15,670 |
| | 80 | 62.9 | 13,060 | 65.2 | 13,060 | 67.3 | 13,060 |
| | 90 | 58.8 | 11,080 | 61.1 | 11,080 | 63.1 | 11,080 |
| | 100 | 54.5 | 9,530 | 56.7 | 9,530 | 58.7 | 9,530 |
| | 110 | 49.9 | 8,280 | 52.1 | 8,280 | 53.9 | 8,280 |
| | 120 | 45.0 | 7,250 | 47.1 | 7,260 | 48.8 | 7,260 |

| | | | | | | | |
|----------------------|-----|------|---------|------|---------|------|---------|
| | 34 | 80.9 | 22,500* | - | - | - | - |
| | 35 | 80.6 | 22,500* | - | - | - | - |
| | 40 | 78.9 | 22,500* | - | - | - | - |
| | 50 | 75.4 | 22,020* | 77.7 | 20,170* | 79.8 | 16,440* |
| 130' (39.6 m) | 60 | 71.9 | 19,060 | 74.1 | 19,060 | 76.2 | 16,240* |
| | 70 | 68.3 | 15,480 | 70.5 | 15,480 | 72.5 | 15,480 |
| | 80 | 64.7 | 12,870 | 66.8 | 12,880 | 68.8 | 12,880 |
| | 90 | 60.9 | 10,900 | 63.0 | 10,900 | 64.9 | 10,910 |
| | 100 | 56.9 | 9,350 | 59.0 | 9,350 | 60.8 | 9,360 |
| | 110 | 52.7 | 8,100 | 54.8 | 8,100 | 56.6 | 8,110 |
| | 120 | 48.3 | 7,070 | 50.4 | 7,080 | 52.0 | 7,080 |
| | 130 | 43.6 | 6,220 | 45.5 | 6,220 | 47.1 | 6,220 |

| Boom length | Jib Radius (Feet) | 5.0 Deg offset Boom Angle | 5.0 Deg offset Rating (Pounds) | 15.0 Deg offset Boom Angle | 15.0 Deg offset Rating (Pounds) | 25.0 Deg offset Boom Angle | 25.0 Deg offset Rating (Pounds) |
|----------------------|-------------------|---------------------------|--------------------------------|----------------------------|---------------------------------|----------------------------|---------------------------------|
| | 36 | 80.8 | 20,590* | - | - | - | - |
| | 40 | 79.5 | 20,210* | - | - | - | - |
| | 50 | 76.3 | 19,260* | 78.4 | 17,060* | 80.4 | 13,890* |
| | 60 | 73.0 | 18,250* | 75.1 | 16,430* | 77.0 | 13,600* |
| 140' (42.7 m) | 70 | 69.6 | 15,280 | 71.7 | 15,280 | 73.6 | 13,240* |
| | 80 | 66.2 | 12,680 | 68.2 | 12,680 | 70.1 | 12,680 |
| | 90 | 62.6 | 10,700 | 64.7 | 10,700 | 66.5 | 10,700 |
| | 100 | 59.0 | 9,140 | 61.0 | 9,150 | 62.7 | 9,150 |
| | 110 | 55.1 | 7,890 | 57.1 | 7,900 | 58.8 | 7,900 |
| | 120 | 51.1 | 6,860 | 53.1 | 6,870 | 54.7 | 6,870 |
| | 130 | 46.9 | 6,010 | 48.8 | 6,010 | 50.3 | 6,010 |
| | 140 | 42.3 | 5,280 | 44.1 | 5,280 | 45.5 | 5,290 |

| | | | | | | | |
|----------------------|-----|------|---------|------|---------|------|---------|
| | 37 | 81.0 | 17,400* | - | - | - | - |
| | 40 | 80.1 | 17,190* | - | - | - | - |
| | 50 | 77.0 | 16,300* | 79.0 | 14,440* | 80.9 | 11,750* |
| | 60 | 73.9 | 15,370* | 75.9 | 13,860* | 77.7 | 11,470* |
| | 70 | 70.7 | 14,480* | 72.7 | 13,220* | 74.5 | 11,070* |
| | 80 | 67.5 | 12,480 | 69.4 | 12,480 | 71.2 | 10,580* |
| 150' (45.7 m) | 90 | 64.2 | 10,500 | 66.1 | 10,500 | 67.8 | 10,060* |
| | 100 | 60.8 | 8,950 | 62.7 | 8,950 | 64.4 | 8,950 |
| | 110 | 57.2 | 7,700 | 59.1 | 7,700 | 60.7 | 7,700 |
| | 120 | 53.5 | 6,670 | 55.4 | 6,670 | 57.0 | 6,670 |
| | 130 | 49.7 | 5,810 | 51.5 | 5,810 | 53.0 | 5,810 |
| | 140 | 45.5 | 5,080 | 47.3 | 5,080 | 48.7 | 5,090 |
| | 150 | 41.1 | 4,460 | 42.8 | 4,460 | 44.1 | 4,460 |

| | | | | | | | |
|----------------------|-----|------|---------|------|---------|------|--------|
| | 39 | 80.9 | 14,750* | - | - | - | - |
| | 40 | 80.6 | 14,670* | - | - | - | - |
| | 50 | 77.7 | 13,800* | 79.6 | 12,290* | - | - |
| | 60 | 74.7 | 12,930* | 76.6 | 11,740* | 78.4 | 9,670* |
| | 70 | 71.7 | 12,130* | 73.6 | 11,100* | 75.3 | 9,260* |
| | 80 | 68.7 | 11,330* | 70.5 | 10,480* | 72.2 | 8,800* |
| 160' (48.8 m) | 90 | 65.6 | 10,310 | 67.4 | 9,820* | 69.1 | 8,290* |
| | 100 | 62.4 | 8,760 | 64.2 | 8,760 | 65.8 | 7,810* |
| | 110 | 59.1 | 7,510 | 60.9 | 7,510 | 62.4 | 7,320* |
| | 120 | 55.6 | 6,480 | 57.4 | 6,480 | 58.9 | 6,480 |
| | 130 | 52.1 | 5,620 | 53.8 | 5,620 | 55.3 | 5,620 |
| | 140 | 48.3 | 4,890 | 50.0 | 4,890 | 51.4 | 4,900 |
| | 150 | 44.3 | 4,270 | 46.0 | 4,270 | 47.3 | 4,270 |
| | 160 | 40.0 | 3,720 | 41.6 | 3,720 | 42.8 | 3,730 |

3

WITH 47HI BOOM, #9HL JIB
58,100 lb
360°
ANSI B 30.5
50' (15.2 m) Jib length

| Boom length | Jib Radius (Feet) | 5.0 Deg offset | | 15.0 Deg offset | | 25.0 Deg offset | |
|----------------------|-------------------|----------------|-----------------|-----------------|-----------------|-----------------|-----------------|
| | | Boom Angle | Rating (Pounds) | Boom Angle | Rating (Pounds) | Boom Angle | Rating (Pounds) |
| | 37 | 80.8 | 21,570* | - | - | - | - |
| | 40 | 79.8 | 21,570* | - | - | - | - |
| | 50 | 76.5 | 21,210* | 79.2 | 18,370* | - | - |
| | 60 | 73.2 | 19,110 | 75.9 | 17,960* | 78.3 | 14,430* |
| 130' (39.6 m) | 70 | 69.9 | 15,520 | 72.5 | 15,520 | 74.9 | 14,230* |
| | 80 | 66.4 | 12,920 | 69.0 | 12,920 | 71.4 | 12,920 |
| | 90 | 62.9 | 10,940 | 65.5 | 10,940 | 67.8 | 10,940 |
| | 100 | 59.2 | 9,380 | 61.8 | 9,390 | 64.0 | 9,390 |
| | 110 | 55.4 | 8,130 | 57.9 | 8,140 | 60.1 | 8,140 |
| | 120 | 51.4 | 7,100 | 53.8 | 7,110 | 55.9 | 7,110 |
| | 130 | 47.1 | 6,250 | 49.5 | 6,250 | 51.5 | 6,250 |

| | | | | | | | |
|----------------------|-----|------|---------|------|---------|------|---------|
| | 38 | 80.9 | 19,020* | - | - | - | - |
| | 40 | 80.3 | 19,010* | - | - | - | - |
| | 50 | 77.3 | 18,100* | 79.8 | 15,590* | - | - |
| | 60 | 74.2 | 17,210* | 76.6 | 15,150* | 79.0 | 12,140* |
| 140' (42.7 m) | 70 | 71.0 | 15,330 | 73.5 | 14,540* | 75.8 | 11,930* |
| | 80 | 67.8 | 12,720 | 70.2 | 12,720 | 72.5 | 11,570* |
| | 90 | 64.4 | 10,740 | 66.9 | 10,740 | 69.1 | 10,740 |
| | 100 | 61.0 | 9,190 | 63.4 | 9,190 | 65.6 | 9,190 |
| | 110 | 57.5 | 7,940 | 59.9 | 7,940 | 62.0 | 7,940 |
| | 120 | 53.8 | 6,910 | 56.1 | 6,910 | 58.2 | 6,910 |
| | 130 | 49.9 | 6,050 | 52.2 | 6,050 | 54.2 | 6,050 |
| | 140 | 45.8 | 5,310 | 48.0 | 5,310 | 49.9 | 5,320 |

| | | | | | | | |
|----------------------|-----|------|---------|------|---------|------|---------|
| | 40 | 80.8 | 16,220* | - | - | - | - |
| | 50 | 77.9 | 15,410* | 80.3 | 13,300* | - | - |
| | 60 | 75.0 | 14,500* | 77.3 | 12,800* | 79.6 | 10,310* |
| | 70 | 72.0 | 13,690* | 74.3 | 12,280* | 76.5 | 10,040* |
| 150' (45.7 m) | 80 | 68.9 | 12,520 | 71.3 | 11,690* | 73.4 | 9,660* |
| | 90 | 65.8 | 10,530 | 68.1 | 10,540 | 70.2 | 9,270* |
| | 100 | 62.6 | 8,980 | 64.9 | 8,980 | 67.0 | 8,810* |
| | 110 | 59.3 | 7,730 | 61.6 | 7,730 | 63.6 | 7,730 |
| | 120 | 55.9 | 6,700 | 58.1 | 6,700 | 60.1 | 6,700 |
| | 130 | 52.3 | 5,840 | 54.5 | 5,840 | 56.4 | 5,850 |
| | 140 | 48.5 | 5,110 | 50.7 | 5,110 | 52.5 | 5,120 |
| | 150 | 44.5 | 4,490 | 46.7 | 4,490 | 48.4 | 4,490 |

| Boom length | Jib Radius (Feet) | 5.0 Deg offset | | 15.0 Deg offset | | 25.0 Deg offset | |
|----------------------|-------------------|----------------|-----------------|-----------------|-----------------|-----------------|-----------------|
| | | Boom Angle | Rating (Pounds) | Boom Angle | Rating (Pounds) | Boom Angle | Rating (Pounds) |
| | 41 | 81.0 | 13,810* | - | - | - | - |
| | 50 | 78.5 | 13,090* | 80.8 | 11,330* | - | - |
| | 60 | 75.7 | 12,280* | 78.0 | 10,860* | 80.1 | 8,710* |
| | 70 | 72.9 | 11,490* | 75.1 | 10,330* | 77.2 | 8,420* |
| | 80 | 70.0 | 10,770* | 72.2 | 9,800* | 74.3 | 8,050* |
| | 90 | 67.0 | 10,080* | 69.2 | 9,220* | 71.3 | 7,660* |
| 160' (48.8 m) | 100 | 64.0 | 8,790 | 66.2 | 8,680* | 68.2 | 7,240* |
| | 110 | 60.9 | 7,540 | 63.1 | 7,540 | 65.0 | 6,830* |
| | 120 | 57.7 | 6,510 | 59.9 | 6,510 | 61.8 | 6,410* |
| | 130 | 54.4 | 5,650 | 56.5 | 5,650 | 58.4 | 5,660 |
| | 140 | 50.9 | 4,920 | 53.0 | 4,920 | 54.8 | 4,930 |
| | 150 | 47.3 | 4,300 | 49.3 | 4,300 | 51.0 | 4,300 |
| | 160 | 43.4 | 3,760 | 45.4 | 3,760 | 47.0 | 3,770 |

| | | | | | | | |
|----------------------|-----|------|---------|------|--------|------|--------|
| | 43 | 80.9 | 11,660* | - | - | - | - |
| | 50 | 79.0 | 11,130* | - | - | - | - |
| | 60 | 76.4 | 10,340* | 78.5 | 9,190* | 80.6 | 7,380* |
| | 70 | 73.7 | 9,620* | 75.8 | 8,650* | 77.8 | 7,040* |
| | 80 | 70.9 | 8,940* | 73.1 | 8,150* | 75.0 | 6,670* |
| | 90 | 68.1 | 8,300* | 70.3 | 7,600* | 72.2 | 6,290* |
| 170' (51.8 m) | 100 | 65.3 | 7,710* | 67.4 | 7,120* | 69.3 | 5,870* |
| | 110 | 62.4 | 7,120* | 64.4 | 6,600* | 66.3 | 5,480* |
| | 120 | 59.4 | 6,310 | 61.4 | 6,150* | 63.2 | 5,090* |
| | 130 | 56.3 | 5,450 | 58.3 | 5,460 | 60.1 | 4,690* |
| | 140 | 53.0 | 4,720 | 55.1 | 4,730 | 56.8 | 4,310* |
| | 150 | 49.7 | 4,100 | 51.6 | 4,100 | 53.3 | 3,920* |
| | 160 | 46.1 | 3,550 | 48.1 | 3,550 | 49.6 | 3,540* |
| | 170 | 42.3 | 3,070 | 44.2 | 3,080 | 45.7 | 3,080 |

WITH 47HI BOOM, #9HL JIB

 **58,100 lb**

360°

ANSI B 30.5

60' (18.3 m) Jib length

| Boom length | Jib Radius (Feet) | 5.0 Deg offset | | 15.0 Deg offset | | 25.0 Deg offset | |
|----------------------|-------------------|----------------|-----------------|-----------------|-----------------|-----------------|-----------------|
| | | Boom Angle | Rating (Pounds) | Boom Angle | Rating (Pounds) | Boom Angle | Rating (Pounds) |
| | 42 | 80.9 | 15,150* | - | - | - | - |
| | 50 | 78.7 | 14,500* | - | - | - | - |
| | 60 | 75.9 | 13,720* | 78.7 | 11,780* | - | - |
| | 70 | 73.1 | 12,920* | 75.8 | 11,350* | 78.3 | 8,990* |
| 150' (45.7 m) | 80 | 70.2 | 12,170* | 72.9 | 10,860* | 75.4 | 8,750* |
| | 90 | 67.3 | 10,580 | 69.9 | 10,340* | 72.4 | 8,460* |
| | 100 | 64.3 | 9,010 | 66.9 | 9,020 | 69.3 | 8,120* |
| | 110 | 61.2 | 7,760 | 63.8 | 7,760 | 66.1 | 7,740* |
| | 120 | 58.0 | 6,730 | 60.6 | 6,730 | 62.9 | 6,740 |
| | 130 | 54.6 | 5,870 | 57.2 | 5,870 | 59.4 | 5,880 |
| | 140 | 51.2 | 5,140 | 53.7 | 5,150 | 55.9 | 5,150 |
| | 150 | 47.5 | 4,520 | 50.0 | 4,520 | 52.1 | 4,520 |

| | | | | | | | |
|----------------------|-----|------|---------|------|---------|------|--------|
| | 44 | 80.8 | 12,820* | - | - | - | - |
| | 50 | 79.3 | 12,400* | - | - | - | - |
| | 60 | 76.6 | 11,610* | 79.2 | 10,040* | - | - |
| | 70 | 73.9 | 10,890* | 76.5 | 9,560* | 78.9 | 7,600* |
| | 80 | 71.1 | 10,220* | 73.7 | 9,090* | 76.1 | 7,340* |
| | 90 | 68.4 | 9,570* | 70.9 | 8,630* | 73.3 | 7,020* |
| 160' (48.8 m) | 100 | 65.5 | 8,830 | 68.0 | 8,130* | 70.4 | 6,680* |
| | 110 | 62.6 | 7,580 | 65.1 | 7,580 | 67.4 | 6,310* |
| | 120 | 59.6 | 6,540 | 62.1 | 6,550 | 64.3 | 5,960* |
| | 130 | 56.5 | 5,680 | 58.9 | 5,690 | 61.1 | 5,600* |
| | 140 | 53.3 | 4,950 | 55.7 | 4,960 | 57.8 | 4,960 |
| | 150 | 49.9 | 4,330 | 52.3 | 4,330 | 54.3 | 4,330 |
| | 160 | 46.3 | 3,790 | 48.7 | 3,790 | 50.6 | 3,800 |

| Boom length | Jib Radius (Feet) | 5.0 Deg offset | | 15.0 Deg offset | | 25.0 Deg offset | |
|----------------------|-------------------|----------------|-----------------|-----------------|-----------------|-----------------|-----------------|
| | | Boom Angle | Rating (Pounds) | Boom Angle | Rating (Pounds) | Boom Angle | Rating (Pounds) |
| | 45 | 81.0 | 10,920* | - | - | - | - |
| | 50 | 79.7 | 10,520* | - | - | - | - |
| | 60 | 77.2 | 9,830* | 79.7 | 8,510* | - | - |
| | 70 | 74.6 | 9,130* | 77.1 | 8,060* | 79.4 | 6,380* |
| | 80 | 72.0 | 8,500* | 74.5 | 7,580* | 76.8 | 6,110* |
| | 90 | 69.4 | 7,880* | 71.8 | 7,140* | 74.1 | 5,780* |
| 170' (51.8 m) | 100 | 66.6 | 7,300* | 69.1 | 6,660* | 71.3 | 5,440* |
| | 110 | 63.9 | 6,780* | 66.3 | 6,210* | 68.5 | 5,090* |
| | 120 | 61.1 | 6,270* | 63.4 | 5,780* | 65.6 | 4,740* |
| | 130 | 58.1 | 5,490 | 60.5 | 5,370* | 62.6 | 4,390* |
| | 140 | 55.1 | 4,750 | 57.5 | 4,700 | 59.5 | 4,060* |
| | 150 | 52.0 | 4,130 | 54.3 | 4,130 | 56.3 | 3,710* |
| | 160 | 48.7 | 3,580 | 51.0 | 3,580 | 52.9 | 3,380* |
| | 170 | 45.2 | 3,100 | 47.5 | 3,110 | 49.3 | 3,040* |

NOTES TO LIFTING CAPACITY

Warning

This rating chart is invalid if the crane has been modified or altered by use of other than GENUINE AMERICAN PARTS as such modifications or alterations may affect its capacity or safe operation. See American Crane Corporation Service Bulliten #259.

Ratings in this chart are in POUNDS and do not exceed the percentage of tipping specified for this crane by ANSI B30.5. All ratings require that the crane be standing level on a firm uniformly supporting surface.

Do not lift loads in excess of those shown on this chart. Lifting loads in excess of those shown or operation not in accordance with good operating practice, including limitations shown on page 3499 of Operator's Manual, can cause tipping, structural damage or catastrophic failure.

Asterisk (*) areas on this chart indicate ratings which are limited by strength of material or factors other than stability (tipping).

„RADIUS IN FEET“ is the horizontal distance at ground level from the crane centerline of rotation to a vertical line through the center of gravity of the suspended load.

When using the main boom fall with jib in place, the main fall ratings must be reduced by the jib effective weight shown on the jib rating chart plus twice the weight of all suspended blocks, slings, rope, etc., at the jib fall. See Appendix A.

Blocks, slings, buckets and other load carrying devices are considered part of the load. The weight of standard hoisting ropes for the rating at a given radius has been calculated as part of the boom point load and need not be considered in determining net allowable loads. See Appendix A.

Ratings shown on this chart make no allowance for such factors as out of plumb loads, wind, poor soil conditions, improper inflation of rubber tires and dynamic effects due to excessive operating speeds. The user (operator) must exercise judgement to make allowance for these conditions. See page 3499 of Operator's Manual for detailed information.

No account is taken of the wind force on the load. This effect, which can be substantial for loads with large surface areas, must be considered by the user. In any wind it is strongly recommended that taglines be used to control the load.

BOOM HOIST LINE is 14 parts of 5/8 inch diameter EIPS wire rope with a minimum breaking strength of 41,200 pounds.

PENDANT SUSPENSION LINE is 2 parts of 1-1/4 inch diameter MONOLAY wire rope with a minimum breaking strength of 172,800 pounds.

WHIP LINE is 7/8 inch diameter EIPS wire rope with a minimum breaking strength of 79,600 pounds.

ERECTION

Erection is with the A-Frame fully raised. Erection „OVER THE END“ is with the boom over the idler end. Erection „OVER THE SIDE“ is with the boom 90° to the sideframes and with the side frames extended. Blocks, slings and other load carrying devices must be on the ground during erection.

| 47HI BOOM COMPOSITION CHART | | | | | |
|-----------------------------|----------------|----------------|----------------|----------------|-----------------------|
| BOOM LENGTH (FEET) | BOOM SECTIONS | | | | |
| | 20' 47HI INNER | 10' 47H CENTER | 20' 47H CENTER | 30' 47H CENTER | 20' 47H or 47HI OUTER |
| 40 | 1 | 0 | 0 | 0 | 1 |
| 50 | 1 | 1 | 0 | 0 | 1 |
| 60 | 1 | 0 | 1 | 0 | 1 |
| 70 | 1 | 0 | 0 | 1 | 1 |
| 80 | 1 | 1 | 0 | 1 | 1 |
| 90 | 1 | 0 | 1 | 1 | 1 |
| 100 | 1 | 0 | 0 | 2 | 1 |
| 110 | 1 | 1 | 0 | 2 | 1 |
| 120 | 1 | 0 | 1 | 2 | 1 |
| 130 | 1 | 0 | 0 | 3 | 1 |
| 140 | 1 | 1 | 0 | 3 | 1 |
| 150 | 1 | 0 | 1 | 3 | 1 |
| 160 | 1 | 0 | 0 | 4 | 1 |
| 170 | 1 | 1 | 0 | 4 | 1 |

| MAXIMUM BOOM & JIB SELF-ERECTION DATA | | |
|---------------------------------------|------------------------------|-------------------|
| | OVER THE END & OVER THE SIDE | |
| | BOOM LENGTH (FEET) | JIB LENGTH (FEET) |
| #9HL JIB | 200 170 | 0 60 |

| LOAD HOISTING INFORMATION - 7/8" EIPS ROPE | | | |
|--|-----------------------|----------------------------------|---------------|
| MAXIMUM LIFTING CAPACITY - LBS. | MINIMUM PARTS OF LINE | MAXIMUM HOISTING DISTANCE - FEET | |
| | | MAIN - (RIGHT) | AUX. - (LEFT) |
| 22,550 | 1 | 588 | 588 |

| #9HL JIB COMPOSITION CHART | | | | | | | | |
|----------------------------|-----------|------------|------------|-----------|--------------------------|------------------------|--------|--------|
| JIB LENGTH (FEET) | 20' INNER | 10' CENTER | 20' CENTER | 20' OUTER | EFF. JIB WEIGHT (POUNDS) | JIB OFFSET "A" IN FEET | | |
| | | | | | | 5° | 15° | 25° |
| 40 | 1 | 0 | 0 | 1 | 1,850 | 4.75' | 9.75' | 14.66' |
| 50 | 1 | 1 | 0 | 1 | 2,350 | 5.50' | 11.66' | 17.83' |
| 60 | 1 | 0 | 1 | 1 | 2,750 | 6.08' | 13.50' | 20.75' |

Note: The #9HL jib mounted on a 47HI outer requires the use of a 47HI / #9HL jib adaptor. Refer to the HC 80 Operators Manual for additional information.

RANGE DIAGRAM, 46HI BOOM, #9 ANGLE JIB

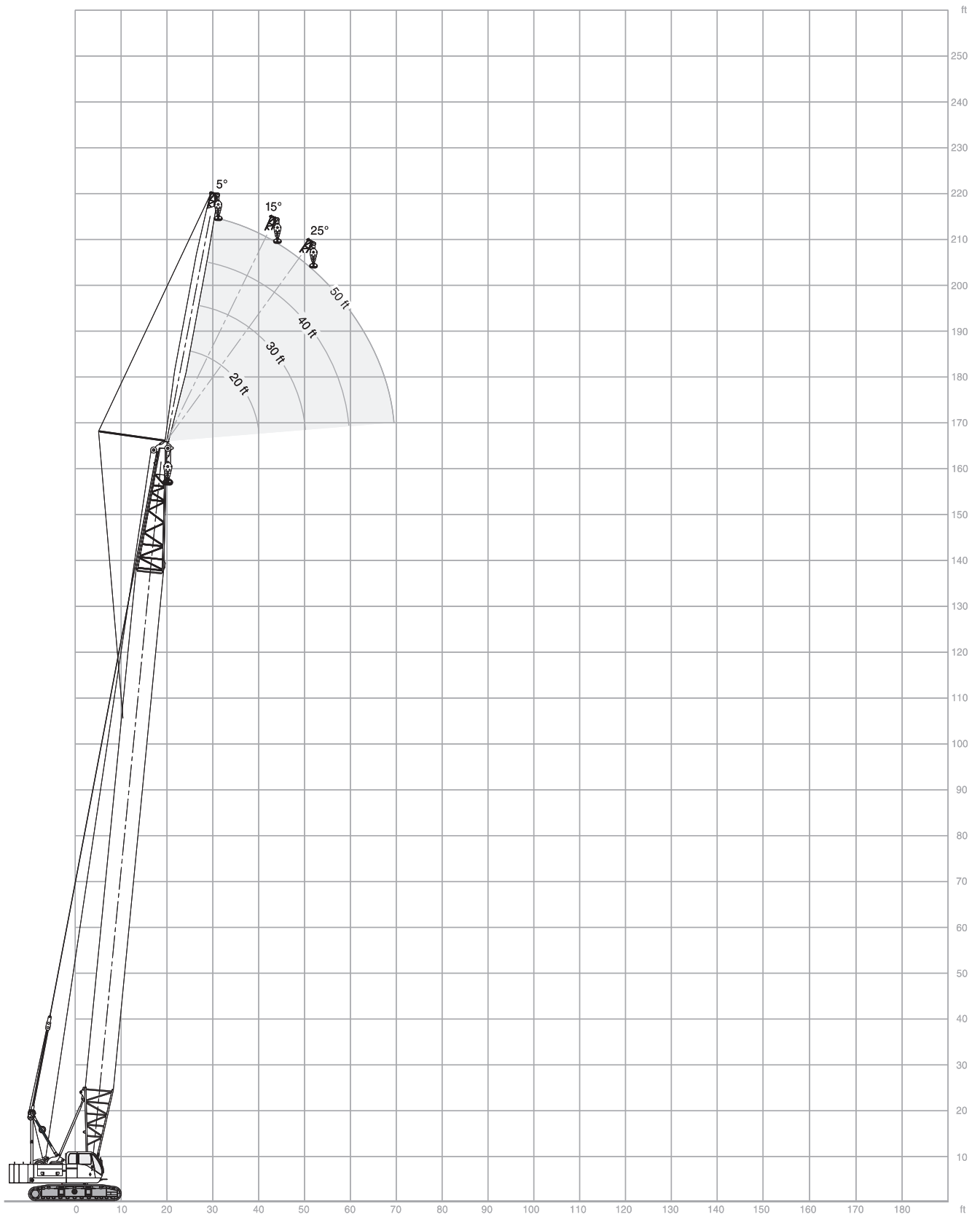

WITH 46HI BOOM, #9 ANGLE JIB
 **58,100 lb**
360°
ANSI B 30.5
20' (6.1 m) Jib length

| Boom length | Jib Radius (Feet) | 5.0 Deg offset | | 15.0 Deg offset | | 25.0 Deg offset | |
|---------------------|-------------------|----------------|-----------------|-----------------|-----------------|-----------------|-----------------|
| | | Boom Angle | Rating (Pounds) | Boom Angle | Rating (Pounds) | Boom Angle | Rating (Pounds) |
| | 17 | 80.7 | 18,250* | - | - | - | - |
| | 20 | 78.2 | 18,250* | 80.9 | 18,250* | - | - |
| 50' (15.2 m) | 25 | 74.1 | 18,250* | 76.7 | 18,250* | 79.2 | 18,250* |
| | 30 | 69.8 | 18,250* | 72.5 | 18,250* | 74.9 | 18,250* |
| | 35 | 65.5 | 18,250* | 68.1 | 18,250* | 70.5 | 18,250* |
| | 40 | 60.9 | 18,250* | 63.5 | 18,250* | 65.8 | 18,250* |
| | 50 | 51.1 | 18,250* | 53.6 | 18,250* | 55.7 | 18,250* |

| | | | | | | | |
|---------------------|----|------|---------|------|---------|------|---------|
| | 19 | 80.4 | 18,250* | - | - | - | - |
| | 20 | 79.7 | 18,250* | - | - | - | - |
| 60' (18.3 m) | 25 | 76.1 | 18,250* | 78.4 | 18,250* | 80.6 | 18,250* |
| | 30 | 72.4 | 18,250* | 74.7 | 18,250* | 76.9 | 18,250* |
| | 35 | 68.7 | 18,250* | 71.0 | 18,250* | 73.1 | 18,250* |
| | 40 | 64.8 | 18,250* | 67.1 | 18,250* | 69.1 | 18,250* |
| | 50 | 56.7 | 18,250* | 58.9 | 18,250* | 60.8 | 18,250* |
| | 60 | 47.6 | 18,250* | 49.7 | 18,250* | 51.5 | 18,250* |

| | | | | | | | |
|---------------------|----|------|---------|------|---------|------|---------|
| | 20 | 80.8 | 18,250* | - | - | - | - |
| | 25 | 77.6 | 18,250* | 79.7 | 18,250* | - | - |
| 70' (21.3 m) | 30 | 74.4 | 18,250* | 76.5 | 18,250* | 78.4 | 18,250* |
| | 35 | 71.1 | 18,250* | 73.2 | 18,250* | 75.1 | 18,250* |
| | 40 | 67.7 | 18,250* | 69.8 | 18,250* | 71.6 | 18,250* |
| | 50 | 60.7 | 18,250* | 62.7 | 18,250* | 64.5 | 18,250* |
| | 60 | 53.2 | 18,250* | 55.1 | 18,250* | 56.8 | 18,250* |
| | 70 | 44.7 | 16,020 | 46.6 | 16,020 | 48.1 | 16,020 |

| | | | | | | | |
|---------------------|----|------|---------|------|---------|------|---------|
| | 22 | 80.6 | 18,250* | - | - | - | - |
| | 25 | 78.9 | 18,250* | 80.8 | 18,250* | - | - |
| | 30 | 76.0 | 18,250* | 77.8 | 18,250* | 79.6 | 18,250* |
| | 35 | 73.0 | 18,250* | 74.9 | 18,250* | 76.6 | 18,250* |
| | 40 | 70.0 | 18,250* | 71.9 | 18,250* | 73.6 | 18,000* |
| 80' (24.4 m) | 50 | 63.9 | 18,250* | 65.7 | 18,250* | 67.3 | 18,250* |
| | 60 | 57.3 | 18,250* | 59.1 | 18,250* | 60.6 | 18,250* |
| | 70 | 50.3 | 15,820 | 52.0 | 15,820 | 53.4 | 15,820 |
| | 80 | 42.3 | 13,220 | 44.0 | 13,220 | 45.2 | 13,220 |

| | | | | | | | |
|---------------------|----|------|---------|------|---------|------|---------|
| | 23 | 80.9 | 18,250* | - | - | - | - |
| | 25 | 79.9 | 18,250* | - | - | - | - |
| | 30 | 77.2 | 18,250* | 79.0 | 18,250* | 80.6 | 18,250* |
| | 35 | 74.6 | 18,250* | 76.3 | 18,250* | 77.9 | 18,250* |
| 90' (27.4 m) | 40 | 71.9 | 18,250* | 73.6 | 18,250* | 75.1 | 18,250* |
| | 50 | 66.4 | 18,250* | 68.0 | 18,250* | 69.5 | 18,250* |
| | 60 | 60.6 | 18,250* | 62.2 | 18,250* | 63.6 | 18,250* |
| | 70 | 54.5 | 15,570 | 56.0 | 15,570 | 57.4 | 15,580 |
| | 80 | 47.8 | 12,980 | 49.3 | 12,980 | 50.6 | 12,980 |
| | 90 | 40.3 | 11,000 | 41.7 | 11,000 | 42.8 | 11,000 |

| | | | | | | | |
|----------------------|-----|------|---------|------|---------|------|---------|
| | 25 | 80.7 | 18,250* | - | - | - | - |
| | 30 | 78.3 | 18,250* | 79.9 | 18,250* | - | - |
| | 35 | 75.9 | 18,250* | 77.5 | 18,250* | 78.9 | 18,250* |
| | 40 | 73.4 | 18,250* | 75.0 | 18,250* | 76.4 | 18,250* |
| 100' (30.5 m) | 50 | 68.4 | 18,250* | 70.0 | 18,250* | 71.3 | 18,250* |
| | 60 | 63.2 | 18,250* | 64.7 | 18,250* | 66.1 | 18,250* |
| | 70 | 57.8 | 15,350 | 59.3 | 15,350 | 60.5 | 15,350 |
| | 80 | 52.0 | 12,740 | 53.4 | 12,740 | 54.6 | 12,740 |
| | 90 | 45.6 | 10,760 | 47.0 | 10,760 | 48.1 | 10,760 |
| | 100 | 38.5 | 9,220 | 39.8 | 9,220 | 40.7 | 9,220 |

| Boom length | Jib Radius (Feet) | 5.0 Deg offset | | 15.0 Deg offset | | 25.0 Deg offset | |
|----------------------|-------------------|----------------|-----------------|-----------------|-----------------|-----------------|-----------------|
| | | Boom Angle | Rating (Pounds) | Boom Angle | Rating (Pounds) | Boom Angle | Rating (Pounds) |
| | 26 | 81.0 | 18,250* | - | - | - | - |
| | 30 | 79.2 | 18,250* | 80.7 | 18,250* | - | - |
| | 35 | 77.0 | 18,250* | 78.4 | 18,250* | 79.8 | 18,250* |
| | 40 | 74.7 | 18,250* | 76.2 | 18,250* | 77.5 | 18,250* |
| 110' (33.5 m) | 50 | 70.2 | 18,250* | 71.6 | 18,250* | 72.9 | 18,250* |
| | 60 | 65.4 | 18,250* | 66.8 | 18,250* | 68.1 | 18,250* |
| | 70 | 60.5 | 15,100 | 61.9 | 15,100 | 63.1 | 15,100 |
| | 80 | 55.3 | 12,500 | 56.7 | 12,500 | 57.8 | 12,500 |
| | 90 | 49.8 | 10,520 | 51.1 | 10,520 | 52.2 | 10,520 |
| | 100 | 43.7 | 8,960 | 45.0 | 8,970 | 46.0 | 8,970 |
| | 110 | 36.9 | 7,720 | 38.1 | 7,720 | 38.9 | 7,720 |

| | | | | | | | |
|----------------------|-----|------|---------|------|---------|------|---------|
| | 28 | 80.8 | 18,250* | - | - | - | - |
| | 30 | 80.0 | 18,250* | - | - | - | - |
| | 35 | 77.9 | 18,250* | 79.3 | 18,250* | 80.5 | 18,250* |
| | 40 | 75.8 | 18,250* | 77.2 | 18,250* | 78.4 | 18,250* |
| 120' (36.6 m) | 50 | 71.6 | 18,250* | 72.9 | 18,250* | 74.1 | 18,250* |
| | 60 | 67.3 | 18,250* | 68.6 | 18,250* | 69.7 | 18,250* |
| | 70 | 62.8 | 14,890 | 64.1 | 14,890 | 65.2 | 14,900 |
| | 80 | 58.1 | 12,290 | 59.4 | 12,290 | 60.4 | 12,290 |
| | 90 | 53.2 | 10,310 | 54.4 | 10,310 | 55.4 | 10,310 |
| | 100 | 47.9 | 8,750 | 49.1 | 8,750 | 50.0 | 8,760 |
| | 110 | 42.1 | 7,510 | 43.2 | 7,510 | 44.1 | 7,510 |
| | 120 | 35.5 | 6,490 | 36.6 | 6,490 | 37.3 | 6,490 |

| | | | | | | | |
|----------------------|-----|------|---------|------|---------|------|---------|
| | 30 | 80.7 | 18,250* | - | - | - | - |
| | 35 | 78.7 | 18,250* | 80.0 | 18,250* | - | - |
| | 40 | 76.8 | 18,250* | 78.0 | 18,250* | 79.2 | 18,250* |
| | 50 | 72.9 | 18,250* | 74.1 | 18,250* | 75.2 | 18,250* |
| | 60 | 68.9 | 18,250* | 70.1 | 18,250* | 71.2 | 18,250* |
| | 70 | 64.7 | 14,660 | 65.9 | 14,660 | 67.0 | 14,660 |
| 130' (39.6 m) | 80 | 60.4 | 12,060 | 61.6 | 12,060 | 62.7 | 12,060 |
| | 90 | 56.0 | 10,070 | 57.1 | 10,080 | 58.1 | 10,080 |
| | 100 | 51.2 | 8,520 | 52.4 | 8,520 | 53.3 | 8,520 |
| | 110 | 46.1 | 7,270 | 47.3 | 7,270 | 48.1 | 7,270 |
| | 120 | 40.6 | 6,230 | 41.6 | 6,230 | 42.4 | 6,240 |
| | 130 | 34.3 | 5,380 | 35.3 | 5,380 | 35.9 | 5,390 |

| | | | | | | | |
|----------------------|-----|------|---------|------|---------|------|---------|
| | 31 | 80.9 | 18,250* | - | - | - | - |
| | 35 | 79.4 | 18,250* | 80.6 | 18,250* | - | - |
| | 40 | 77.6 | 18,250* | 78.8 | 18,250* | 79.9 | 18,250* |
| | 50 | 74.0 | 18,250* | 75.1 | 18,250* | 76.2 | 18,250* |
| | 60 | 70.2 | 18,030 | 71.4 | 18,030 | 72.4 | 18,030 |
| | 70 | 66.4 | 14,430 | 67.5 | 14,430 | 68.5 | 14,430 |
| 140' (42.7 m) | 80 | 62.4 | 11,820 | 63.6 | 11,820 | 64.5 | 11,820 |
| | 90 | 58.3 | 9,840 | 59.4 | 9,840 | 60.4 | 9,840 |
| | 100 | 54.0 | 8,290 | 55.1 | 8,290 | 56.0 | 8,290 |
| | 110 | 49.5 | 7,030 | 50.6 | 7,030 | 51.4 | 7,030 |
| | 120 | 44.6 | 6,000 | 45.6 | 6,000 | 46.4 | 6,010 |
| | 130 | 39.2 | 5,150 | 40.2 | 5,150 | 40.9 | 5,150 |
| | 140 | 33.1 | 4,420 | 34.1 | 4,420 | 34.6 | 4,420 |

WITH 46HI BOOM, #9 ANGLE JIB

58,100 lb

360°

ANSI B 30.5

20' (6.1 m) Jib length

| Boom length | Jib Radius (Feet) | 5.0 Deg offset | | 15.0 Deg offset | | 25.0 Deg offset | |
|----------------------|-------------------|----------------|-----------------|-----------------|-----------------|-----------------|-----------------|
| | | Boom Angle | Rating (Pounds) | Boom Angle | Rating (Pounds) | Boom Angle | Rating (Pounds) |
| | 33 | 80.7 | 18,250* | - | - | - | - |
| | 35 | 80.1 | 18,250* | - | - | - | - |
| | 40 | 78.4 | 18,250* | 79.5 | 18,250* | 80.5 | 18,250* |
| | 50 | 74.9 | 18,250* | 76.0 | 18,250* | 77.0 | 18,250* |
| | 60 | 71.4 | 17,790 | 72.5 | 17,790 | 73.5 | 17,790 |
| | 70 | 67.8 | 14,200 | 68.9 | 14,200 | 69.9 | 14,200 |
| 150' (45.7 m) | 80 | 64.2 | 11,580 | 65.2 | 11,580 | 66.2 | 11,590 |
| | 90 | 60.4 | 9,600 | 61.4 | 9,600 | 62.3 | 9,600 |
| | 100 | 56.4 | 8,040 | 57.5 | 8,040 | 58.3 | 8,040 |
| | 110 | 52.3 | 6,790 | 53.3 | 6,790 | 54.1 | 6,790 |
| | 120 | 47.9 | 5,760 | 48.9 | 5,760 | 49.7 | 5,770 |
| | 130 | 43.2 | 4,900 | 44.2 | 4,900 | 44.9 | 4,900 |
| | 140 | 38.0 | 4,170 | 38.9 | 4,170 | 39.6 | 4,180 |
| | 150 | 32.1 | 3,550 | 33.0 | 3,560 | 33.5 | 3,560 |

| Boom length | Jib Radius (Feet) | 5.0 Deg offset | | 15.0 Deg offset | | 25.0 Deg offset | |
|----------------------|-------------------|----------------|-----------------|-----------------|-----------------|-----------------|-----------------|
| | | Boom Angle | Rating (Pounds) | Boom Angle | Rating (Pounds) | Boom Angle | Rating (Pounds) |
| | 34 | 80.9 | 18,250* | - | - | - | - |
| | 35 | 80.6 | 18,250* | - | - | - | - |
| | 40 | 79.0 | 18,250* | 80.1 | 18,250* | - | - |
| | 50 | 75.8 | 18,250* | 76.8 | 18,250* | 77.8 | 16,580* |
| | 60 | 72.5 | 17,580 | 73.5 | 17,580 | 74.5 | 15,770* |
| | 70 | 69.1 | 13,990 | 70.2 | 13,990 | 71.1 | 13,990 |
| 160' (48.8 m) | 80 | 65.7 | 11,380 | 66.7 | 11,380 | 67.6 | 11,380 |
| | 90 | 62.2 | 9,390 | 63.2 | 9,400 | 64.0 | 9,400 |
| | 100 | 58.5 | 7,830 | 59.5 | 7,830 | 60.3 | 7,840 |
| | 110 | 54.7 | 6,580 | 55.7 | 6,580 | 56.5 | 6,590 |
| | 120 | 50.7 | 5,540 | 51.7 | 5,540 | 52.4 | 5,550 |
| | 130 | 46.5 | 4,690 | 47.4 | 4,690 | 48.1 | 4,690 |
| | 140 | 41.9 | 3,950 | 42.8 | 3,950 | 43.5 | 3,950 |
| | 150 | 36.9 | 3,330 | 37.8 | 3,330 | 38.3 | 3,330 |
| | 160 | 31.2 | 2,790 | 32.0 | 2,790 | 32.4 | 2,790 |

30' (9.1 m) Jib length

| Boom length | Jib Radius (Feet) | 5.0 Deg offset | | 15.0 Deg offset | | 25.0 Deg offset | |
|---------------------|-------------------|----------------|-----------------|-----------------|-----------------|-----------------|-----------------|
| | | Boom Angle | Rating (Pounds) | Boom Angle | Rating (Pounds) | Boom Angle | Rating (Pounds) |
| | 24 | 80.8 | 18,250* | - | - | - | - |
| | 25 | 80.3 | 18,250* | - | - | - | - |
| | 30 | 77.7 | 18,250* | 80.3 | 18,250* | - | - |
| | 35 | 75.0 | 18,250* | 77.6 | 18,250* | 80.0 | 18,250* |
| 80' (24.4 m) | 40 | 72.3 | 18,250* | 74.9 | 18,250* | 77.3 | 18,250* |
| | 50 | 66.8 | 18,250* | 69.3 | 18,250* | 71.6 | 18,250* |
| | 60 | 61.0 | 18,250* | 63.5 | 18,250* | 65.7 | 18,250* |
| | 70 | 54.9 | 15,910 | 57.3 | 15,920 | 59.4 | 15,920 |
| | 80 | 48.2 | 13,320 | 50.6 | 13,320 | 52.5 | 13,320 |

| Boom length | Jib Radius (Feet) | 5.0 Deg offset | | 15.0 Deg offset | | 25.0 Deg offset | |
|----------------------|-------------------|----------------|-----------------|-----------------|-----------------|-----------------|-----------------|
| | | Boom Angle | Rating (Pounds) | Boom Angle | Rating (Pounds) | Boom Angle | Rating (Pounds) |
| | 29 | 80.7 | 18,250* | - | - | - | - |
| | 30 | 80.3 | 18,250* | - | - | - | - |
| | 35 | 78.3 | 18,250* | 80.3 | 18,250* | - | - |
| | 40 | 76.2 | 18,250* | 78.2 | 18,250* | 80.1 | 18,250* |
| 110' (33.5 m) | 50 | 72.0 | 18,250* | 74.0 | 18,250* | 75.8 | 18,250* |
| | 60 | 67.6 | 18,250* | 69.6 | 18,250* | 71.4 | 18,250* |
| | 70 | 63.1 | 15,180 | 65.1 | 15,180 | 66.8 | 15,190 |
| | 80 | 58.4 | 12,570 | 60.4 | 12,570 | 62.0 | 12,580 |
| | 90 | 53.5 | 10,590 | 55.4 | 10,590 | 57.0 | 10,600 |
| | 100 | 48.2 | 9,040 | 50.0 | 9,050 | 51.5 | 9,050 |
| | 110 | 42.4 | 7,790 | 44.2 | 7,790 | 45.6 | 7,790 |

| | | | | | | | |
|---------------------|----|------|---------|------|---------|------|---------|
| | 26 | 80.6 | 18,250* | - | - | - | - |
| | 30 | 78.7 | 18,250* | - | - | - | - |
| | 35 | 76.3 | 18,250* | 78.7 | 18,250* | 80.9 | 18,250* |
| | 40 | 73.8 | 18,250* | 76.2 | 18,250* | 78.4 | 18,250* |
| 90' (27.4 m) | 50 | 68.8 | 18,250* | 71.2 | 18,250* | 73.3 | 18,250* |
| | 60 | 63.6 | 18,250* | 65.9 | 18,250* | 68.0 | 18,250* |
| | 70 | 58.2 | 15,670 | 60.4 | 15,670 | 62.4 | 15,670 |
| | 80 | 52.4 | 13,060 | 54.6 | 13,060 | 56.4 | 13,060 |
| | 90 | 46.0 | 11,080 | 48.1 | 11,080 | 49.9 | 11,080 |

| | | | | | | | |
|----------------------|-----|------|---------|------|---------|------|---------|
| | 30 | 81.0 | 18,250* | - | - | - | - |
| | 35 | 79.1 | 18,250* | 81.0 | 18,250* | - | - |
| | 40 | 77.1 | 18,250* | 79.0 | 18,250* | 80.8 | 18,250* |
| | 50 | 73.2 | 18,250* | 75.1 | 18,250* | 76.8 | 18,250* |
| 120' (36.6 m) | 60 | 69.2 | 18,250* | 71.0 | 18,250* | 72.7 | 18,250* |
| | 70 | 65.0 | 14,970 | 66.9 | 14,970 | 68.5 | 14,970 |
| | 80 | 60.8 | 12,370 | 62.6 | 12,370 | 64.2 | 12,370 |
| | 90 | 56.3 | 10,380 | 58.1 | 10,390 | 59.6 | 10,390 |
| | 100 | 51.5 | 8,830 | 53.3 | 8,830 | 54.7 | 8,830 |
| | 110 | 46.5 | 7,580 | 48.2 | 7,580 | 49.5 | 7,580 |
| | 120 | 40.9 | 6,540 | 42.5 | 6,540 | 43.8 | 6,550 |

| | | | | | | | |
|----------------------|-----|------|---------|------|---------|------|---------|
| | 27 | 80.9 | 18,250* | - | - | - | - |
| | 30 | 79.6 | 18,250* | - | - | - | - |
| | 35 | 77.4 | 18,250* | 79.5 | 18,250* | - | - |
| | 40 | 75.1 | 18,250* | 77.3 | 18,250* | 79.3 | 18,250* |
| 100' (30.5 m) | 50 | 70.5 | 18,250* | 72.7 | 18,250* | 74.7 | 18,250* |
| | 60 | 65.8 | 18,250* | 67.9 | 18,250* | 69.8 | 18,250* |
| | 70 | 60.9 | 15,430 | 63.0 | 15,430 | 64.8 | 15,430 |
| | 80 | 55.7 | 12,820 | 57.7 | 12,820 | 59.5 | 12,820 |
| | 90 | 50.2 | 10,840 | 52.2 | 10,840 | 53.8 | 10,840 |
| | 100 | 44.1 | 9,290 | 46.0 | 9,300 | 47.6 | 9,300 |

| | | | | | | | |
|----------------------|-----|------|---------|------|---------|------|---------|
| | 32 | 80.8 | 18,250* | - | - | - | - |
| | 35 | 79.7 | 18,250* | - | - | - | - |
| | 40 | 77.9 | 18,250* | 79.7 | 18,250* | - | - |
| | 50 | 74.3 | 18,250* | 76.0 | 18,250* | 77.7 | 18,250* |
| 130' (39.6 m) | 60 | 70.5 | 18,250* | 72.3 | 18,250* | 73.9 | 18,250* |
| | 70 | 66.7 | 14,730 | 68.4 | 14,730 | 70.0 | 14,740 |
| | 80 | 62.7 | 12,120 | 64.4 | 12,120 | 66.0 | 12,120 |
| | 90 | 58.6 | 10,140 | 60.3 | 10,140 | 61.8 | 10,140 |
| | 100 | 54.3 | 8,580 | 56.0 | 8,580 | 57.4 | 8,580 |
| | 110 | 49.8 | 7,330 | 51.4 | 7,330 | 52.7 | 7,330 |
| | 120 | 44.9 | 6,300 | 46.5 | 6,300 | 47.7 | 6,310 |
| | 130 | 39.5 | 5,440 | 41.0 | 5,440 | 42.2 | 5,440 |

3

WITH 46HI BOOM, #9 ANGLE JIB
58,100 lb
360°
ANSI B 30.5
30' (9.1 m) Jib length

| Boom length | Jib Radius (Feet) | 5.0 Deg offset | | 15.0 Deg offset | | 25.0 Deg offset | |
|----------------------|-------------------|----------------|-----------------|-----------------|-----------------|-----------------|-----------------|
| | | Boom Angle | Rating (Pounds) | Boom Angle | Rating (Pounds) | Boom Angle | Rating (Pounds) |
| | 34 | 80.7 | 18,250* | - | - | - | - |
| | 35 | 80.3 | 18,250* | - | - | - | - |
| | 40 | 78.6 | 18,250* | 80.3 | 18,250* | - | - |
| | 50 | 75.2 | 18,250* | 76.9 | 18,250* | 78.4 | 18,250* |
| | 60 | 71.7 | 18,090 | 73.4 | 18,090 | 74.9 | 18,090 |
| | 70 | 68.1 | 14,500 | 69.8 | 14,500 | 71.2 | 14,500 |
| 140' (42.7 m) | 80 | 64.5 | 11,880 | 66.1 | 11,880 | 67.5 | 11,890 |
| | 90 | 60.7 | 9,900 | 62.3 | 9,900 | 63.7 | 9,900 |
| | 100 | 56.7 | 8,350 | 58.3 | 8,350 | 59.6 | 8,350 |
| | 110 | 52.6 | 7,090 | 54.1 | 7,090 | 55.4 | 7,090 |
| | 120 | 48.2 | 6,060 | 49.7 | 6,060 | 50.9 | 6,070 |
| | 130 | 43.5 | 5,210 | 44.9 | 5,210 | 46.1 | 5,210 |
| | 140 | 38.3 | 4,470 | 39.7 | 4,480 | 40.7 | 4,480 |

| Boom length | Jib Radius (Feet) | 5.0 Deg offset | | 15.0 Deg offset | | 25.0 Deg offset | |
|----------------------|-------------------|----------------|-----------------|-----------------|-----------------|-----------------|-----------------|
| | | Boom Angle | Rating (Pounds) | Boom Angle | Rating (Pounds) | Boom Angle | Rating (Pounds) |
| | 37 | 80.8 | 18,250* | - | - | - | - |
| | 40 | 79.8 | 18,250* | - | - | - | - |
| | 50 | 76.8 | 18,250* | 78.3 | 17,840* | 79.7 | 14,960* |
| | 60 | 73.7 | 17,640 | 75.2 | 17,030* | 76.5 | 14,430* |
| | 70 | 70.5 | 14,050 | 72.0 | 14,050 | 73.3 | 13,770* |
| | 80 | 67.3 | 11,430 | 68.8 | 11,430 | 70.1 | 11,440 |
| 160' (48.8 m) | 90 | 64.0 | 9,450 | 65.4 | 9,450 | 66.7 | 9,450 |
| | 100 | 60.6 | 7,890 | 62.0 | 7,890 | 63.3 | 7,890 |
| | 110 | 57.1 | 6,640 | 58.5 | 6,640 | 59.7 | 6,640 |
| | 120 | 53.4 | 5,600 | 54.8 | 5,600 | 55.9 | 5,600 |
| | 130 | 49.5 | 4,740 | 50.9 | 4,740 | 52.0 | 4,740 |
| | 140 | 45.4 | 4,010 | 46.7 | 4,010 | 47.8 | 4,010 |
| | 150 | 41.0 | 3,380 | 42.3 | 3,380 | 43.2 | 3,380 |
| | 160 | 36.1 | 2,840 | 37.3 | 2,850 | 38.2 | 2,850 |

| | | | | | | | |
|----------------------|-----|------|---------|------|---------|------|---------|
| | 35 | 80.9 | 18,250* | - | - | - | - |
| | 40 | 79.3 | 18,250* | 80.9 | 18,250* | - | - |
| | 50 | 76.0 | 18,250* | 77.6 | 18,250* | 79.1 | 17,490* |
| | 60 | 72.8 | 17,860 | 74.3 | 17,860 | 75.7 | 16,980* |
| | 70 | 69.4 | 14,260 | 70.9 | 14,260 | 72.3 | 14,260 |
| | 80 | 66.0 | 11,650 | 67.5 | 11,650 | 68.9 | 11,650 |
| 150' (45.7 m) | 90 | 62.4 | 9,660 | 63.9 | 9,670 | 65.3 | 9,670 |
| | 100 | 58.8 | 8,100 | 60.3 | 8,100 | 61.6 | 8,110 |
| | 110 | 55.0 | 6,850 | 56.5 | 6,850 | 57.7 | 6,860 |
| | 120 | 51.0 | 5,810 | 52.4 | 5,810 | 53.6 | 5,820 |
| | 130 | 46.8 | 4,960 | 48.2 | 4,960 | 49.3 | 4,960 |
| | 140 | 42.2 | 4,220 | 43.5 | 4,220 | 44.6 | 4,230 |
| | 150 | 37.2 | 3,600 | 38.5 | 3,600 | 39.4 | 3,600 |

40' (12.2 m) Jib length

| Boom length | Jib Radius (Feet) | 5.0 Deg offset | | 15.0 Deg offset | | 25.0 Deg offset | |
|----------------------|-------------------|----------------|-----------------|-----------------|-----------------|-----------------|-----------------|
| | | Boom Angle | Rating (Pounds) | Boom Angle | Rating (Pounds) | Boom Angle | Rating (Pounds) |
| | 30 | 80.7 | 18,250* | - | - | - | - |
| | 35 | 78.6 | 18,250* | - | - | - | - |
| | 40 | 76.5 | 18,250* | 79.3 | 18,250* | - | - |
| | 50 | 72.3 | 18,250* | 75.0 | 17,790* | 77.5 | 16,310* |
| 100' (30.5 m) | 60 | 68.0 | 18,250* | 70.6 | 16,840* | 73.1 | 15,650* |
| | 70 | 63.5 | 15,480 | 66.1 | 15,490 | 68.5 | 15,060* |
| | 80 | 58.8 | 12,880 | 61.4 | 12,880 | 63.7 | 12,890 |
| | 90 | 53.9 | 10,900 | 56.4 | 10,900 | 58.6 | 10,910 |
| | 100 | 48.6 | 9,340 | 51.0 | 9,350 | 53.1 | 9,350 |

| Boom length | Jib Radius (Feet) | 5.0 Deg offset | | 15.0 Deg offset | | 25.0 Deg offset | |
|----------------------|-------------------|----------------|-----------------|-----------------|-----------------|-----------------|-----------------|
| | | Boom Angle | Rating (Pounds) | Boom Angle | Rating (Pounds) | Boom Angle | Rating (Pounds) |
| | 33 | 80.8 | 18,250* | - | - | - | - |
| | 35 | 80.1 | 18,250* | - | - | - | - |
| | 40 | 78.2 | 18,250* | 80.6 | 18,250* | - | - |
| | 50 | 74.6 | 18,250* | 76.9 | 18,220* | 79.1 | 16,560* |
| 120' (36.6 m) | 60 | 70.8 | 18,250* | 73.2 | 17,310* | 75.3 | 15,890* |
| | 70 | 67.0 | 15,020 | 69.3 | 15,020 | 71.4 | 15,030 |
| | 80 | 63.1 | 12,410 | 65.3 | 12,410 | 67.4 | 12,410 |
| | 90 | 58.9 | 10,430 | 61.2 | 10,430 | 63.2 | 10,430 |
| | 100 | 54.6 | 8,870 | 56.9 | 8,870 | 58.8 | 8,870 |
| | 110 | 50.1 | 7,620 | 52.3 | 7,620 | 54.1 | 7,620 |
| | 120 | 45.2 | 6,590 | 47.3 | 6,590 | 49.0 | 6,600 |

| | | | | | | | |
|----------------------|-----|------|---------|------|---------|------|---------|
| | 31 | 80.9 | 18,250* | - | - | - | - |
| | 35 | 79.4 | 18,250* | - | - | - | - |
| | 40 | 77.4 | 18,250* | 80.0 | 18,250* | - | - |
| | 50 | 73.5 | 18,250* | 76.0 | 17,950* | 78.4 | 16,410* |
| 110' (33.5 m) | 60 | 69.5 | 18,250* | 72.0 | 17,070* | 74.3 | 15,760* |
| | 70 | 65.4 | 15,240 | 67.8 | 15,240 | 70.1 | 15,200* |
| | 80 | 61.1 | 12,630 | 63.5 | 12,630 | 65.7 | 12,630 |
| | 90 | 56.6 | 10,640 | 59.0 | 10,650 | 61.1 | 10,650 |
| | 100 | 51.9 | 9,090 | 54.2 | 9,090 | 56.2 | 9,090 |
| | 110 | 46.8 | 7,840 | 49.1 | 7,840 | 51.0 | 7,840 |

| | | | | | | | |
|----------------------|-----|------|---------|------|---------|------|---------|
| | 34 | 81.0 | 18,250* | - | - | - | - |
| | 35 | 80.6 | 18,250* | - | - | - | - |
| | 40 | 78.9 | 18,250* | - | - | - | - |
| | 50 | 75.5 | 18,250* | 77.7 | 18,250* | 79.8 | 16,640* |
| 130' (39.6 m) | 60 | 72.0 | 18,250* | 74.2 | 17,560* | 76.3 | 16,060* |
| | 70 | 68.4 | 14,780 | 70.6 | 14,780 | 72.6 | 14,780 |
| | 80 | 64.8 | 12,160 | 66.9 | 12,160 | 68.9 | 12,170 |
| | 90 | 61.0 | 10,180 | 63.1 | 10,180 | 65.0 | 10,190 |
| | 100 | 57.0 | 8,630 | 59.1 | 8,630 | 61.0 | 8,630 |
| | 110 | 52.9 | 7,370 | 54.9 | 7,370 | 56.7 | 7,380 |
| | 120 | 48.5 | 6,340 | 50.5 | 6,340 | 52.2 | 6,350 |
| | 130 | 43.8 | 5,480 | 45.7 | 5,480 | 47.3 | 5,480 |

WITH 46HI BOOM, #9 ANGLE JIB

58,100 lb

360°

ANSI B 30.5

40' (12.2 m) Jib length

| Boom length | Jib Radius (Feet) | 5.0 Deg offset | | 15.0 Deg offset | | 25.0 Deg offset | |
|----------------------|-------------------|----------------|-----------------|-----------------|-----------------|-----------------|-----------------|
| | | Boom Angle | Rating (Pounds) | Boom Angle | Rating (Pounds) | Boom Angle | Rating (Pounds) |
| | 36 | 80.8 | 18,250* | - | - | - | - |
| | 40 | 79.6 | 18,250* | - | - | - | - |
| | 50 | 76.3 | 18,250* | 78.4 | 18,250* | 80.4 | 16,720* |
| | 60 | 73.0 | 18,140 | 75.1 | 17,770* | 77.1 | 16,160* |
| 140' (42.7 m) | 70 | 69.7 | 14,540 | 71.7 | 14,540 | 73.6 | 14,550 |
| | 80 | 66.2 | 11,930 | 68.3 | 11,930 | 70.1 | 11,930 |
| | 90 | 62.7 | 9,940 | 64.7 | 9,950 | 66.5 | 9,950 |
| | 100 | 59.1 | 8,390 | 61.1 | 8,390 | 62.8 | 8,400 |
| | 110 | 55.3 | 7,130 | 57.2 | 7,130 | 58.9 | 7,140 |
| | 120 | 51.3 | 6,100 | 53.2 | 6,110 | 54.8 | 6,110 |
| | 130 | 47.0 | 5,250 | 48.9 | 5,250 | 50.5 | 5,250 |
| | 140 | 42.5 | 4,510 | 44.3 | 4,510 | 45.7 | 4,520 |

| | | | | | | | |
|----------------------|-----|------|---------|------|---------|------|---------|
| | 38 | 80.7 | 18,250* | - | - | - | - |
| | 40 | 80.1 | 18,250* | - | - | - | - |
| | 50 | 77.0 | 18,250* | 79.0 | 18,250* | 80.9 | 15,440* |
| | 60 | 73.9 | 17,900 | 75.9 | 17,900* | 77.8 | 15,190* |
| | 70 | 70.8 | 14,310 | 72.7 | 14,310 | 74.6 | 14,310 |
| | 80 | 67.6 | 11,690 | 69.5 | 11,690 | 71.3 | 11,700 |
| 150' (45.7 m) | 90 | 64.3 | 9,710 | 66.2 | 9,710 | 67.9 | 9,710 |
| | 100 | 60.9 | 8,150 | 62.8 | 8,150 | 64.4 | 8,150 |
| | 110 | 57.3 | 6,890 | 59.2 | 6,890 | 60.8 | 6,890 |
| | 120 | 53.7 | 5,860 | 55.5 | 5,860 | 57.1 | 5,860 |
| | 130 | 49.8 | 5,000 | 51.6 | 5,000 | 53.1 | 5,000 |
| | 140 | 45.7 | 4,260 | 47.5 | 4,260 | 48.9 | 4,270 |
| | 150 | 41.3 | 3,640 | 43.0 | 3,640 | 44.3 | 3,640 |

| Boom length | Jib Radius (Feet) | 5.0 Deg offset | | 15.0 Deg offset | | 25.0 Deg offset | |
|----------------------|-------------------|----------------|-----------------|-----------------|-----------------|-----------------|-----------------|
| | | Boom Angle | Rating (Pounds) | Boom Angle | Rating (Pounds) | Boom Angle | Rating (Pounds) |
| | 39 | 80.9 | 18,250* | - | - | - | - |
| | 40 | 80.6 | 18,250* | - | - | - | - |
| | 50 | 77.7 | 18,250* | 79.6 | 16,450* | - | - |
| | 60 | 74.8 | 17,480* | 76.6 | 15,780* | 78.4 | 12,960* |
| | 70 | 71.8 | 14,090 | 73.6 | 14,090 | 75.4 | 12,510* |
| | 80 | 68.7 | 11,480 | 70.6 | 11,480 | 72.3 | 11,480 |
| 160' (48.8 m) | 90 | 65.6 | 9,480 | 67.5 | 9,480 | 69.1 | 9,490 |
| | 100 | 62.4 | 7,930 | 64.3 | 7,930 | 65.9 | 7,930 |
| | 110 | 59.2 | 6,670 | 61.0 | 6,670 | 62.5 | 6,670 |
| | 120 | 55.7 | 5,640 | 57.5 | 5,640 | 59.0 | 5,640 |
| | 130 | 52.2 | 4,770 | 53.9 | 4,770 | 55.4 | 4,770 |
| | 140 | 48.4 | 4,040 | 50.2 | 4,040 | 51.6 | 4,050 |
| | 150 | 44.5 | 3,410 | 46.1 | 3,420 | 47.5 | 3,420 |
| | 160 | 40.2 | 2,870 | 41.8 | 2,870 | 43.0 | 2,880 |

50' (15.2 m) Jib length

| Boom length | Jib Radius (Feet) | 5.0 Deg offset | | 15.0 Deg offset | | 25.0 Deg offset | |
|----------------------|-------------------|----------------|-----------------|-----------------|-----------------|-----------------|-----------------|
| | | Boom Angle | Rating (Pounds) | Boom Angle | Rating (Pounds) | Boom Angle | Rating (Pounds) |
| | 37 | 80.8 | 18,250* | - | - | - | - |
| | 40 | 79.8 | 18,200* | - | - | - | - |
| | 50 | 76.6 | 16,970* | 79.2 | 14,740* | - | - |
| | 60 | 73.3 | 15,830* | 75.9 | 13,950* | 78.4 | 12,580* |
| 130' (39.6 m) | 70 | 69.9 | 14,810 | 72.5 | 13,290* | 75.0 | 12,040* |
| | 80 | 66.5 | 12,200 | 69.1 | 12,200 | 71.5 | 11,630* |
| | 90 | 63.0 | 10,210 | 65.5 | 10,220 | 67.8 | 10,220 |
| | 100 | 59.3 | 8,650 | 61.9 | 8,650 | 64.1 | 8,660 |
| | 110 | 55.5 | 7,400 | 58.0 | 7,400 | 60.2 | 7,410 |
| | 120 | 51.5 | 6,360 | 54.0 | 6,370 | 56.1 | 6,370 |
| | 130 | 47.3 | 5,510 | 49.7 | 5,510 | 51.7 | 5,510 |

| | | | | | | | |
|----------------------|-----|------|---------|------|---------|------|---------|
| | 38 | 81.0 | 18,250* | - | - | - | - |
| | 40 | 80.4 | 18,250* | - | - | - | - |
| | 50 | 77.3 | 17,190* | 79.8 | 14,830* | - | - |
| | 60 | 74.2 | 16,110* | 76.7 | 14,110* | 79.0 | 12,630* |
| 140' (42.7 m) | 70 | 71.0 | 14,580 | 73.5 | 13,440* | 75.8 | 12,150* |
| | 80 | 67.8 | 11,960 | 70.3 | 11,960 | 72.5 | 11,760* |
| | 90 | 64.5 | 9,980 | 66.9 | 9,980 | 69.1 | 9,980 |
| | 100 | 61.1 | 8,420 | 63.5 | 8,420 | 65.7 | 8,420 |
| | 110 | 57.6 | 7,170 | 60.0 | 7,170 | 62.0 | 7,170 |
| | 120 | 53.9 | 6,130 | 56.3 | 6,130 | 58.3 | 6,130 |
| | 130 | 50.1 | 5,270 | 52.3 | 5,270 | 54.3 | 5,270 |
| | 140 | 45.9 | 4,540 | 48.2 | 4,540 | 50.0 | 4,550 |

| Boom length | Jib Radius (Feet) | 5.0 Deg offset | | 15.0 Deg offset | | 25.0 Deg offset | |
|----------------------|-------------------|----------------|-----------------|-----------------|-----------------|-----------------|-----------------|
| | | Boom Angle | Rating (Pounds) | Boom Angle | Rating (Pounds) | Boom Angle | Rating (Pounds) |
| | 40 | 80.9 | 18,250* | - | - | - | - |
| | 50 | 77.9 | 17,430* | 80.3 | 14,980* | - | - |
| | 60 | 75.0 | 16,350* | 77.4 | 14,280* | 79.6 | 12,730* |
| | 70 | 72.0 | 14,330 | 74.4 | 13,580* | 76.6 | 12,230* |
| 150' (45.7 m) | 80 | 69.0 | 11,720 | 71.3 | 11,720 | 73.5 | 11,720 |
| | 90 | 65.9 | 9,730 | 68.2 | 9,730 | 70.3 | 9,740 |
| | 100 | 62.7 | 8,170 | 65.0 | 8,170 | 67.0 | 8,180 |
| | 110 | 59.4 | 6,920 | 61.7 | 6,920 | 63.7 | 6,920 |
| | 120 | 56.0 | 5,880 | 58.2 | 5,880 | 60.2 | 5,880 |
| | 130 | 52.4 | 5,020 | 54.6 | 5,020 | 56.5 | 5,020 |
| | 140 | 48.7 | 4,290 | 50.8 | 4,290 | 52.7 | 4,300 |
| | 150 | 44.7 | 3,660 | 46.8 | 3,670 | 48.5 | 3,670 |

| | | | | | | | |
|----------------------|-----|------|---------|------|---------|------|---------|
| | 42 | 80.7 | 18,250* | - | - | - | - |
| | 50 | 78.5 | 17,480* | 80.8 | 14,960* | - | - |
| | 60 | 75.7 | 16,500* | 78.0 | 14,360* | 80.1 | 11,540* |
| | 70 | 72.9 | 14,120 | 75.1 | 13,740* | 77.2 | 11,230* |
| | 80 | 70.0 | 11,500 | 72.3 | 11,500 | 74.3 | 10,820* |
| | 90 | 67.1 | 9,510 | 69.3 | 9,510 | 71.3 | 9,510 |
| 160' (48.8 m) | 100 | 64.1 | 7,950 | 66.3 | 7,960 | 68.3 | 7,960 |
| | 110 | 61.0 | 6,690 | 63.2 | 6,690 | 65.1 | 6,700 |
| | 120 | 57.8 | 5,660 | 60.0 | 5,660 | 61.8 | 5,670 |
| | 130 | 54.5 | 4,800 | 56.6 | 4,800 | 58.5 | 4,810 |
| | 140 | 51.1 | 4,060 | 53.1 | 4,060 | 54.9 | 4,070 |
| | 150 | 47.4 | 3,430 | 49.5 | 3,440 | 51.2 | 3,440 |
| | 160 | 43.5 | 2,890 | 45.5 | 2,890 | 47.1 | 2,900 |

NOTES TO LIFTING CAPACITY

Warning

This rating chart is invalid if the crane has been modified or altered by use of other than GENUINE AMERICAN PARTS as such modifications or alterations may affect its capacity or safe operation. See American Crane Corporation Service Bulliten #259.

Ratings in this chart are in POUNDS and do not exceed the percentage of tipping specified for this crane by ANSI B30.5. All ratings require that the crane be standing level on a firm uniformly supporting surface.

Do not lift loads in excess of those shown on this chart. Lifting loads in excess of those shown or operation not in accordance with good operating practice, including limitations shown on page 3499 of Operator's Manual, can cause tipping, structural damage or catastrophic failure.

Asterisk (*) areas on this chart indicate ratings which are limited by strength of material or factors other than stability (tipping).

„RADIUS IN FEET“ is the horizontal distance at ground level from the crane centerline of rotation to a vertical line through the center of gravity of the suspended load.

When using the main boom fall with jib in place, the main fall ratings must be reduced by the jib effective weight shown on the jib rating chart plus twice the weight of all suspended blocks, slings, rope, etc., at the jib fall. See Appendix A.

Blocks, slings, buckets and other load carrying devices are considered part of the load. The weight of standard hoisting ropes for the rating at a given radius has been calculated as part of the boom point load and need not be considered in determining net allowable loads. See Appendix A.

Ratings shown on this chart make no allowance for such factors as out of plumb loads, wind, poor soil conditions, improper inflation of rubber tires and dynamic effects due to excessive operating speeds. The user (operator) must exercise judgement to make allowance for these conditions. See page 3499 of Operator's Manual for detailed information.

No account is taken of the wind force on the load. This effect, which can be substantial for loads with large surface areas, must be considered by the user. In any wind it is strongly recommended that taglines be used to control the load.

The weight of all suspended blocks, slings, or other load carrying devices including those at the main fall, are considered part of the jib load. The weight of standard hoisting ropes for the rating at a given radius has been calculated as part of the jib point dead load and need not be considered in determining net allowable loads. See Appendix A.

BOOM HOIST LINE – 14 parts of 5/8 inch diameter EIPS wire rope with a minimum breaking strength of 41,200 pounds.

PENDANT SUSPENSION LINE – 2 parts of 1-1/4 inch diameter MONOLAY wire rope with a minimum breaking strength of 172,800 pounds.

WHIP LINE – 7/8 inch diameter IPS wire rope with a minimum breaking strength of 69,200 pounds.

JIB FRONTSTAY & BACKSTAY PENDANTS – 7/8 inch diameter IPS wire rope with a minimum breaking strength of 69,200 pounds.

ERECTION

Erection is with the A-Frame fully raised. Erection „OVER-THE-END“ is with the boom over the idler end. Erection „OVER-THE-SIDE“ is with the boom 90° to the sideframes and with the side frames extended. Blocks, slings and other load carrying devices must be on the ground during erection.

| MAXIMUM BOOM & JIB SELF-ERECTION DATA - 46HI BOOM | | |
|---|------------------------------|-------------------|
| JIB | OVER-THE END & OVER-THE-SIDE | |
| | BOOM LENGTH (FEET) | JIB LENGTH (FEET) |
| #9 | 160 | 50 |

| 46HI BOOM COMPOSITION CHART | | | | | | |
|-----------------------------|----------------|----------------|-----------------|-----------------|-----------------|------------------------|
| BOOM LENGTH (FEET) | BOOM SECTIONS | | | | | |
| | 20' 46HI INNER | 5' 46HR CENTER | 10' 46HR CENTER | 20' 46HR CENTER | 40' 46HR CENTER | 20' 46HR or 46HI OUTER |
| 40 | 1 | 0 | 0 | 0 | 0 | 1 |
| 45 | 1 | 1 | 0 | 0 | 0 | 1 |
| 50 | 1 | 0 | 1 | 0 | 0 | 1 |
| 55 | 1 | 1 | 0 | 0 | 0 | 1 |
| 60 | 1 | 0 | 0 | 1 | 0 | 1 |
| 65 | 1 | 1 | 0 | 1 | 0 | 1 |
| 70 | 1 | 0 | 1 | 1 | 0 | 1 |
| 75 | 1 | 1 | 1 | 1 | 0 | 1 |
| 80 | 1 | 0 | 0 | 0 | 1 | 1 |
| 85 | 1 | 1 | 0 | 0 | 1 | 1 |
| 90 | 1 | 0 | 1 | 0 | 1 | 1 |
| 95 | 1 | 1 | 1 | 0 | 1 | 1 |
| 100 | 1 | 0 | 0 | 1 | 1 | 1 |
| 105 | 1 | 1 | 0 | 1 | 1 | 1 |
| 110 | 1 | 0 | 1 | 1 | 1 | 1 |
| 115 | 1 | 1 | 1 | 1 | 1 | 1 |
| 120 | 1 | 0 | 0 | 0 | 2 | 1 |
| 125 | 1 | 1 | 0 | 0 | 2 | 1 |
| 130 | 1 | 0 | 1 | 0 | 2 | 1 |
| 135 | 1 | 1 | 1 | 0 | 2 | 1 |
| 140 | 1 | 0 | 0 | 1 | 2 | 1 |
| 145 | 1 | 1 | 0 | 1 | 2 | 1 |
| 150 | 1 | 0 | 1 | 1 | 2 | 1 |
| 155 | 1 | 1 | 1 | 1 | 2 | 1 |
| 160 | 1 | 0 | 0 | 0 | 3 | 1 |

| LOAD HOISTING INFORMATION - 7/8" diameter IPS wire rope | | | |
|---|-----------------------|----------------------------------|---------------|
| MAXIMUM LIFTING CAPACITY - LBS. | MINIMUM PARTS OF LINE | MAXIMUM HOISTING DISTANCE - FEET | |
| | | MAIN - (RIGHT) | AUX. - (LEFT) |
| 18,250 | 1 | 588 | 588 |

| #9 JIB COMPOSITION CHART | | | | | | | |
|--------------------------|-----------|------------|-----------|--------------------------|------------------------|-------|-------|
| JIB LENGTH (FEET) | 10' INNER | 10' CENTER | 10' OUTER | EFF. JIB WEIGHT (POUNDS) | JIB OFFSET "A" IN FEET | | |
| | | | | | 5° | 15° | 25° |
| 20 | 1 | 0 | 1 | 1,550 | 3.75 | 6.00 | 8.50 |
| 30 | 1 | 1 | 1 | 2,100 | 3.50 | 7.83 | 11.58 |
| 40 | 1 | 2 | 1 | 2,800 | 5.08 | 9.67 | 14.50 |
| 50 | 1 | 3 | 1 | 3,600 | 5.33 | 11.58 | 17.75 |

Note: The #9 jib mounted on a 46HI outer requires the use of a 46HI #9 jib adaptor. Refer to the HC 80 Operator's Manual for additional information.

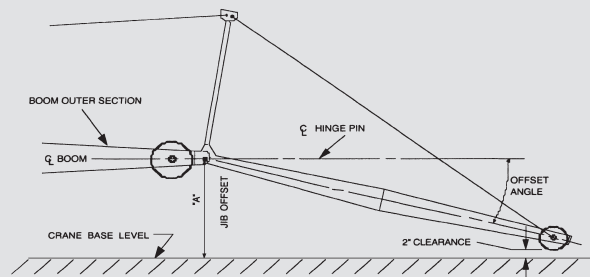

TECHNICAL DESCRIPTION

HYDRAULIC CRAWLER CRANE

Maximum lifting capacity

80 tons (73 mt).

Boom systems

47 HI Boom with Offset Tip

- 200 ft (61 m) maximum boom length.
- 230 ft (70 m) maximum boom and jib combination length.
- 47 HI Tubular chord boom, pin connected.
- 20 ft inner and 20 ft outer and 10 ft / 20 ft / 30 ft available inserts provide boom compositions in 10 ft increments from 40 ft to 200 ft.

46 HR Angle Boom with 4 Sheave Tip

- 160 ft maximum boom length.
- 200 ft (61 m) maximum boom and jib combination length.
- 46 HR Angle Boom, pin connected.
- 20 ft inner and 20 ft outer and 10 ft / 20 ft / 30 ft available inserts provide boom compositions in 10 ft increments from 40 ft to 160 ft.

Robust engine

- Cummins Model QSB 5.9 Turbocharged After Cooled diesel engine, 4 cycle, 6 cylinders, 359 cubic inch displacement, 5.9 liters, 185 BHP @ 2200 rpm, 60 gallons fuel tank capacity.

Environmental operator's cab

- Designed to provide excellent viewing range and quiet, comfortable operation.
- 37 inch (0.91 m) wide cab has wide curve windows on both top and bottom.
- Easy-to-operate modular and ergonomically designed controls reduce operator fatigue and increase productivity.
- Load Moment Indicator with interactive screen features as shockless stop system. Operator can select from three display modes: loaded condition diagram, rated lifting curve or rated lifting load table.
- Adjustable operator's seat, radio, air conditioner, overhead window, sun visor, fan, overhead and front wipers and drum rotation indicators are standard.

Heavy duty carbody and crawlers

- Fabricated steel carbody is deep box constructed with square axles for the crawler side frames. Precision machined top supports anti-friction swing circle and multiple pass hydraulic swivel joint.
- Crawlers have high alloy steel tumbler yokes and rigid fabricated structures with sealed rollers.
- 36" (914 mm) crawler shoes.
- Travel mechanism is set within shoe width.
- Side frames extended or retracted by cylinders inside the carbody.
- Two travel speed settings – 0.8 / 1.24 mph (1.3 / 2.0 km/h).
- 40 % (22°) gradeability.

Powerful, high-speed hoist system

- Identical inline, independent main and auxiliary load hoisting drums are grooved for 7/8 in. (22.4 mm) diameter rope. Line speed is 530 fpm (162 m/min.), line pull is 32,400 lb (14 697 kg).
- Each drum, including optional third, has power up/down and freefall. Load hoists are further controllable in stepless mode.
- Ample work space in front of the drums allows easy access for cable installation and maintenance.
- Internal expanding band clutch.
- 3.3 rpm swing speed.

High capacity, dependable hydraulic system

- Open circuit system has 2 variable displacement piston pumps with system capacity of 116 gpm (440 lpm).
- Hydraulic reservoir with 79 gallons (300 l) capacity and 10 micron filtration.
- Component working range is between -4 and 203° F (-20 and 95° C).
- Flip up doors provide easy access to engine and hydraulic components for service.

Three piece removable counterweight

- Three piece pin connected counterweight can be assembled or disassembled easily within minutes.
- Hydraulic counterweight removal system is standard and utilizes the „A“ frame and crane auxiliary drum to make the HC 80 one of the most transportable cranes in its class.
- Moves on three trucks with full boom and #9HL jib. Carbody sideframes and boom weigh in at under 88,000 lb (39 917 kg). At 11 ft 9.75 in. (3.6 m) wide and 10 ft 2 in. (3.09 m) high, the HC 80 at working weight will transport on a standard lowboy trailer.

Options include

- Third drum
- Automotive type lights
- Hydraulic power take off
- Jib and jib inserts
- Luffing jib attachment
- 46HI angle boom
- Single sheave extension

TRANSPORT EXAMPLE FOR HC 80

170' 47HI BOOM AND 60' #9HL JIB

Loads based on 48 ft flatbed trailer. Loading information is an example only, specific loads will vary depending on crane options. Weights shown do **NOT** include blocking or tie-down material.

| | |
|--|-------------------|
| LOAD NO. 1 | |
| 3 x 47 H 30' Boom Center Sections @ 2,045 # each | 6,135 lbs |
| Inside Counterweight | 16,000 lbs |
| #9HL 20' Jib Center | 385 lbs |
| Center Counterweight | 21,000 lbs |
| 1 x 47 H 10' Boom Center Sections | 700 lbs |
| TOTAL LOAD | 44,220 lbs |
| | |
| LOAD NO. 2 | |
| Outside Counterweight | 21,000 lbs |
| 47HI Boom Outer | 2,225 lbs |
| 47 H 30' Boom Center | 2,045 lbs |
| #9HL Jib Inner | 890 lbs |
| #9HL Jib Outer | 665 lbs |
| Crate, Misc. Parts, Block & Ball | 3,500 lbs |
| TOTAL LOAD | 30,325 lbs |
| | |
| LOAD NO. 3 | |
| Basic Upper, including: | |
| a) Carbody | |
| b) Sideframes | |
| c) Boom Inner | |
| TOTAL LOAD (BASIC CRANE, etc.) | 88,000 lbs |

KEY

| | |
|---|-----------------|
|  | Counterweight |
| CB | Central ballast |

The information contained in this brochure merely consists of general descriptions and a broad compilation of performance features which might not apply precisely as described under specific application conditions or which may change as a result of further product development. The desired performance features only become binding once expressly agreed in the final contract.

Note: Data published herein is intended as a guide only and shall not be construed to warrant applicability for lifting purposes. Crane operation is subject to the computer charts and operation manual both supplied with the crane.

Subject to change without notice.

01 / 06