



HC 275 | Hydraulic Crawler Crane 275 t Lifting Capacity



HC 275

HYDRAULIC CRAWLER CRANE

HC 275

HIGHLIGHTS

- ▶ 275 tons (249.5 mt) maximum lift capacity
- ▶ Power up/down and freefall on main and auxiliary drums
- ▶ Quiet, comfortable operator's cab with excellent viewing range
- ▶ Shockless stop system gradually retards operating speed to reduce shocks when crane approaches lifting load or boom limits
- ▶ Two speed travel allows operator to select the best speed and power control for any condition
- ▶ Superior transportability:
11 ft 6 in. (3.51 m) width
11 ft 3 in. (3.43 m) height
- ▶ Hydraulic counterweight removal system simplifies installation and removal



CONTENTS

	Page:	
Specifications		1
Dimensions	4	
Main boom		2
Range diagram 92HI boom	6	
With 92HI offset tip boom	7	
Jib		3
Range diagram, #30 Jib	12	
With 92HI offset tip boom, #30 Jib	13	
Range diagram, 16HL Jib	30	
With 92HI offset tip boom, 16HL Jib	31	
Technical description		4
Hydraulic Crawler Crane	50	
Transport example for HC 275		5
.....	51	

DIMENSIONS

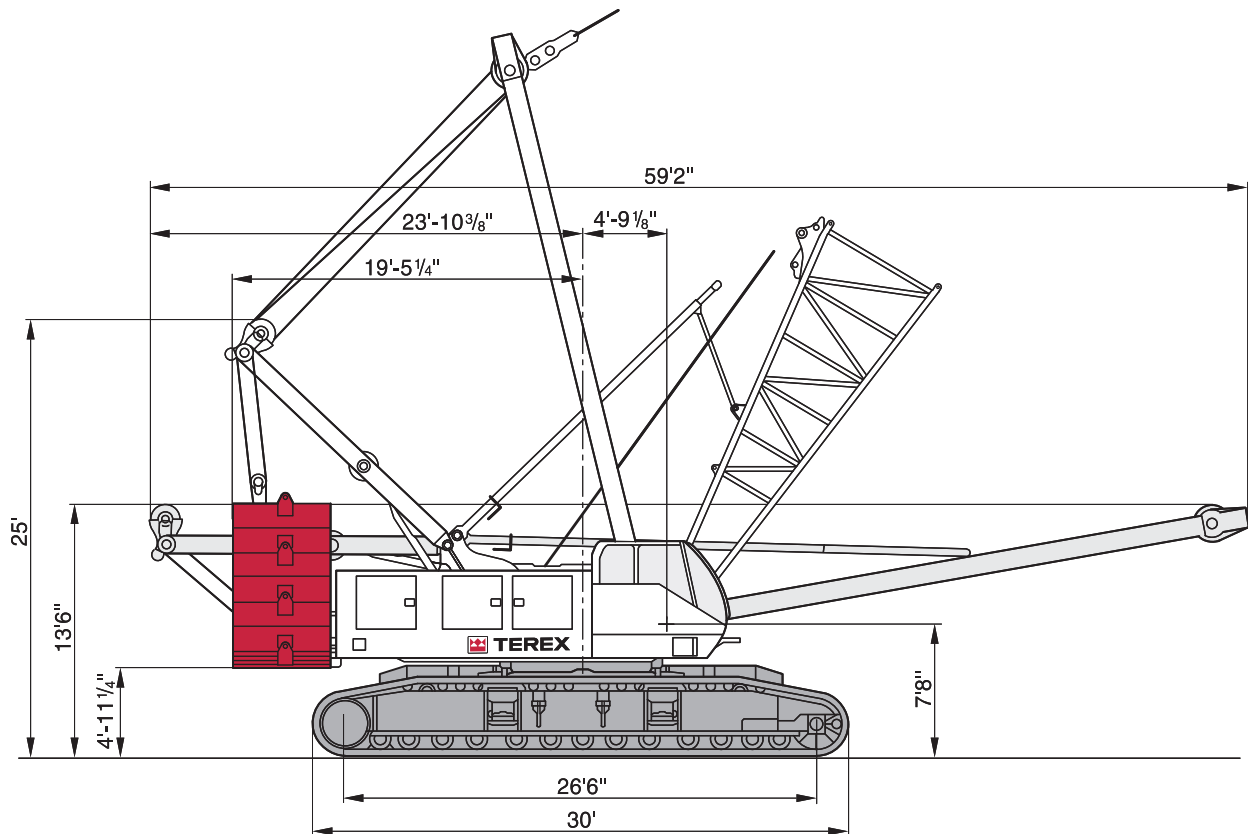

DIMENSIONS

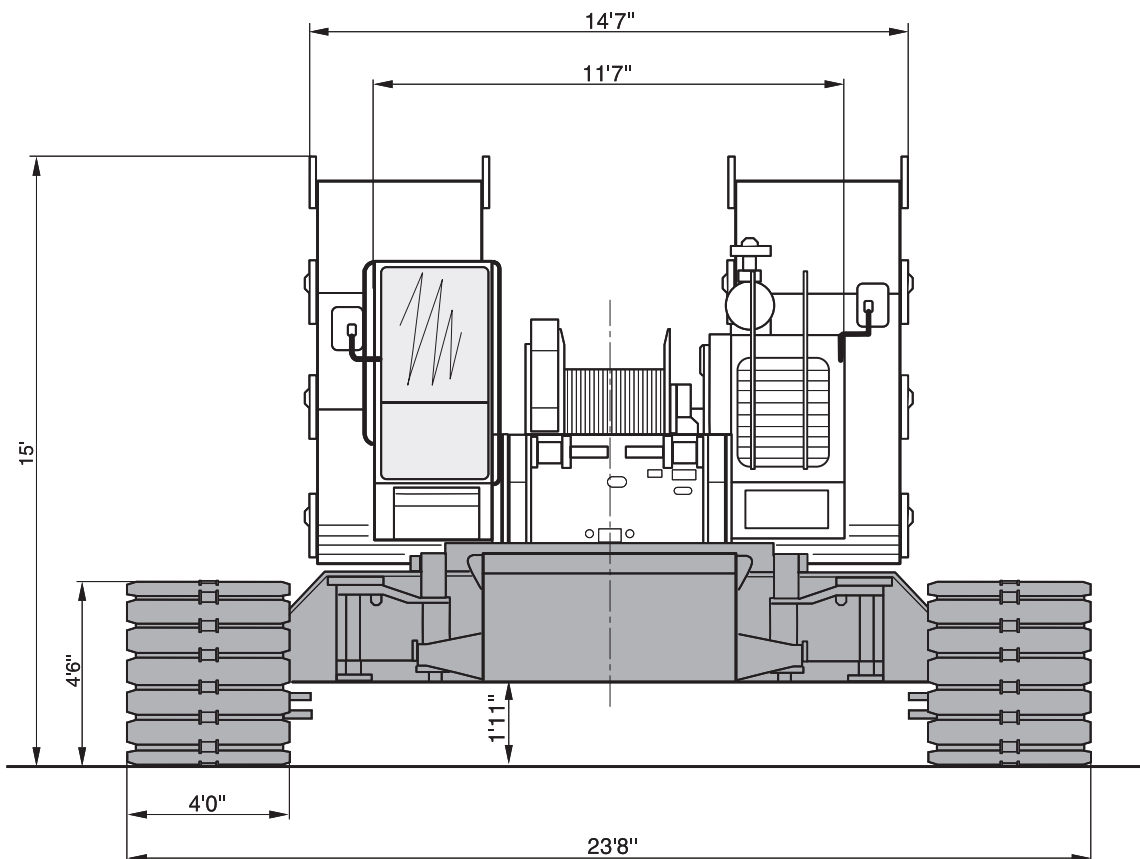

RANGE DIAGRAM 92HI BOOM

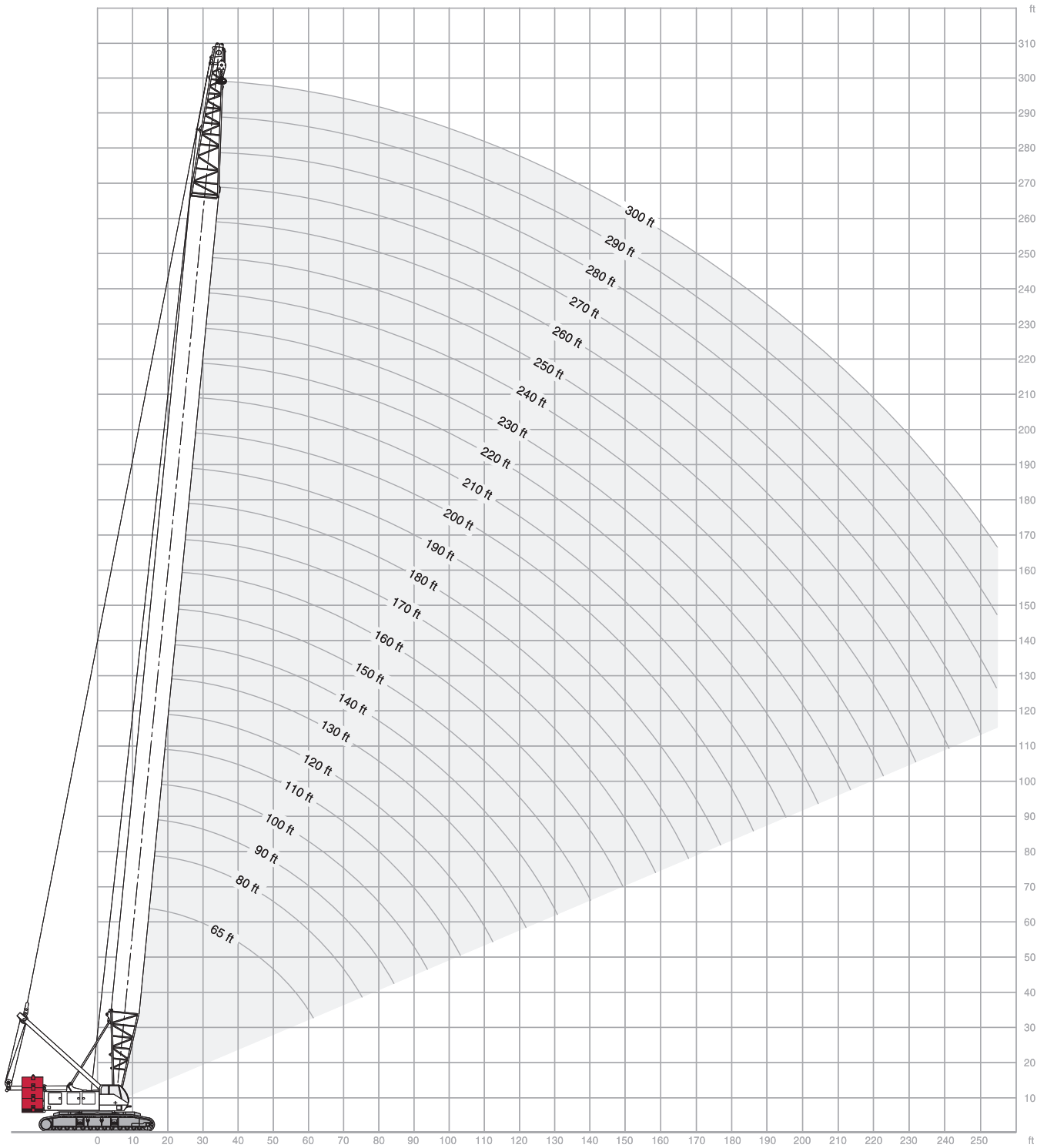

WITH 92HI OFFSET TIP BOOM

195,000 lb + 64,000 lb CB

360°

ANSI B 30.5

65' (21.3 m) Boom length			
Radius (Feet)	Boom Angle (Degrees)	360 Degree Rating (Pounds)	From Boom Pt. to Ground (Feet)
16	81.4	550,000 *	77
20	77.8	438,430 *	76
25	73.2	350,740 *	75
30	68.5	292,250 *	74
35	63.6	232,570	72
40	58.5	191,980	69
50	47.2	141,340	62
60	33.1	111,040	52

80' (24.4 m) Boom length			
Radius (Feet)	Boom Angle (Degrees)	360 Degree Rating (Pounds)	From Boom Pt. to Ground (Feet)
18	81.6	486,730 *	87
20	80.1	438,040 *	86
25	76.4	350,420 *	85
30	72.7	291,950 *	84
35	68.9	232,830	82
40	64.9	192,200	80
50	56.6	141,520	74
60	47.4	111,220	67
70	36.5	90,940	55
80	21.0	76,540	36

90' (27.4 m) Boom length			
Radius (Feet)	Boom Angle (Degrees)	360 Degree Rating (Pounds)	From Boom Pt. to Ground (Feet)
19	81.8	460,720 *	97
20	81.2	437,780 *	97
25	78.0	350,200 *	96
30	74.7	291,750 *	94
35	71.3	232,570	93
40	67.9	191,940	91
50	60.8	141,230	86
60	53.1	110,930	80
70	44.5	90,640	71
80	34.2	76,270	58
90	19.7	65,390	38

100' (30.5 m) Boom length			
Radius (Feet)	Boom Angle (Degrees)	360 Degree Rating (Pounds)	From Boom Pt. to Ground (Feet)
21	81.5	416,560 *	107
25	79.2	349,990 *	106
30	76.2	291,560 *	105
35	73.3	232,180	103
40	70.2	191,530	102
50	64.0	140,800	98
60	57.3	110,500	92
70	50.1	90,190	84
80	42.1	75,850	75
90	32.4	64,980	61
100	18.6	56,510	40

110' (33.5 m) Boom length			
Radius (Feet)	Boom Angle (Degrees)	360 Degree Rating (Pounds)	From Boom Pt. to Ground (Feet)
22	81.8	397,510 *	117
25	80.2	349,770 *	116
30	77.5	291,370 *	115
35	74.8	231,840	114
40	72.1	191,170	112
50	66.5	140,420	109
60	60.6	110,120	104
70	54.4	89,800	97
80	47.6	75,490	89
90	40.0	64,610	78
100	30.8	56,140	64
110	17.7	49,370	41

120' (36.6 m) Boom length			
Radius (Feet)	Boom Angle (Degrees)	360 Degree Rating (Pounds)	From Boom Pt. to Ground (Feet)
23	82.0	373,770 *	126
25	81.0	349,560 *	126
30	78.6	291,180 *	125
35	76.1	231,450	124
40	73.6	190,780	123
50	68.6	140,010	119
60	63.3	109,710	115
70	57.8	89,380	109
80	51.9	75,080	102
90	45.5	64,200	93
100	38.2	55,730	82
110	29.4	48,960	67
120	16.9	43,430	43

130' (39.6 m) Boom length			
Radius (Feet)	Boom Angle (Degrees)	360 Degree Rating (Pounds)	From Boom Pt. to Ground (Feet)
25	81.7	321,040 *	136
30	79.5	287,400 *	135
35	77.2	231,430	134
40	74.9	190,760	133
50	70.3	140,010	130
60	65.5	109,740	126
70	60.5	89,410	121
80	55.3	75,140	115
90	49.7	64,250	107
100	43.6	55,790	97
110	36.6	49,020	85
120	28.2	43,490	69
130	16.2	38,980	44

140' (42.7 m) Boom length			
Radius (Feet)	Boom Angle (Degrees)	360 Degree Rating (Pounds)	From Boom Pt. to Ground (Feet)
26	81.9	297,000 *	146
30	80.2	281,420 *	146
35	78.1	231,040	145
40	76.0	190,370	144
50	71.8	139,590	141
60	67.4	109,320	137
70	62.8	88,970	132
80	58.1	74,720	127
90	53.1	63,820	120
100	47.8	55,360	111
110	41.9	48,590	101
120	35.2	43,060	88
130	27.2	38,600	72
140	15.6	34,660	45

150' (45.7 m) Boom length			
Radius (Feet)	Boom Angle (Degrees)	360 Degree Rating (Pounds)	From Boom Pt. to Ground (Feet)
28	81.7	292,420 *	156
30	80.9	275,620 *	156
35	78.9	230,610	155
40	77.0	189,910	154
50	73.0	139,110	151
60	69.0	108,840	148
70	64.8	88,460	143
80	60.5	74,230	138
90	55.9	63,320	132
100	51.2	54,850	124
110	46.0	48,080	116
120	40.4	42,540	105
130	34.0	38,120	91
140	26.2	34,200	74
150	15.1	30,820	47

WITH 92HI OFFSET TIP BOOM

195,000 lb + 64,000 lb CB

360°

ANSI B 30.5

160' (48.8 m) Boom length			
Radius (Feet)	Boom Angle (Degrees)	360 Degree Rating (Pounds)	From Boom Pt. to Ground (Feet)
29	81.8	270,330 *	166
30	81.5	268,190 *	166
35	79.6	227,390 *	165
40	77.8	189,490	164
50	74.1	138,670	162
60	70.3	108,380	158
70	66.5	88,000	154
80	62.5	73,780	150
90	58.3	62,870	144
100	54.0	54,390	137
110	49.4	47,610	129
120	44.5	42,070	120
130	39.0	37,680	108
140	32.8	33,760	94
150	25.3	30,390	76
160	14.6	27,470	48

170' (51.8 m) Boom length			
Radius (Feet)	Boom Angle (Degrees)	360 Degree Rating (Pounds)	From Boom Pt. to Ground (Feet)
30	82.0	249,690 *	176
35	80.3	223,060 *	175
40	78.5	189,050	174
50	75.1	138,210	172
60	71.5	107,930	169
70	67.9	87,530	165
80	64.2	73,320	161
90	60.4	62,400	155
100	56.4	53,910	149
110	52.3	47,140	142
120	47.8	41,590	134
130	43.0	37,240	124
140	37.8	33,310	112
150	31.8	29,940	97
160	24.6	27,030	78
170	14.1	24,460	49

180' (54.9 m) Boom length			
Radius (Feet)	Boom Angle (Degrees)	360 Degree Rating (Pounds)	From Boom Pt. to Ground (Feet)
32	81.8	215,060 *	186
35	80.8	212,500 *	185
40	79.2	188,840	184
50	75.9	138,010	182
60	72.6	107,760	179
70	69.2	87,350	176
80	65.8	73,170	172
90	62.2	62,250	167
100	58.5	53,770	161
110	54.7	46,990	155
120	50.7	41,440	147
130	46.4	37,130	138
140	41.8	33,200	128
150	36.7	29,840	115
160	30.9	26,910	100
170	23.8	24,370	80
180	13.7	21,830 *	50

190' (57.9 m) Boom length			
Radius (Feet)	Boom Angle (Degrees)	360 Degree Rating (Pounds)	From Boom Pt. to Ground (Feet)
33	81.9	199,300 *	196
35	81.3	197,990 *	195
40	79.8	186,320 *	195
50	76.7	137,580	193
60	73.6	107,310	190
70	70.4	86,890	187
80	67.1	72,720	183
90	63.8	61,800	178
100	60.4	53,300	173
110	56.8	46,510	167
120	53.1	40,960	160
130	49.2	36,670	152
140	45.1	32,760	142
150	40.6	29,390	131
160	35.7	26,470	118
170	30.0	23,920	103
180	23.2	21,670	82
190	13.3	18,900 *	51

200' (61.0 m) Boom length			
Radius (Feet)	Boom Angle (Degrees)	360 Degree Rating (Pounds)	From Boom Pt. to Ground (Feet)
35	81.7	193,970 *	206
40	80.3	183,030 *	205
50	77.4	137,100	203
60	74.4	106,830	200
70	71.4	86,380	197
80	68.3	72,230	194
90	65.2	61,290	189
100	62.0	52,790	184
110	58.7	46,000	179
120	55.3	40,440	172
130	51.7	36,180	165
140	47.9	32,250	156
150	43.9	28,890	146
160	39.5	25,960	135
170	34.7	23,410	122
180	29.2	21,160	105
190	22.6	19,160	84
200	13.0	16,120 *	53

210' (64.0 m) Boom length			
Radius (Feet)	Boom Angle (Degrees)	360 Degree Rating (Pounds)	From Boom Pt. to Ground (Feet)
36	81.8	174,640 *	216
40	80.7	174,640 *	215
50	78.0	136,630	213
60	75.2	106,370	211
70	72.3	85,910	208
80	69.4	71,760	204
90	66.5	60,810	200
100	63.4	52,310	195
110	60.3	45,510	190
120	57.1	40,360	184
130	53.8	35,710	177
140	50.3	31,780	169
150	46.7	28,410	160
160	42.7	25,500	150
170	38.5	22,940	138
180	33.8	20,690	125
190	28.5	18,690	108
200	22.0	16,910	86
210	12.6	13,590 *	54

WITH 92HI OFFSET TIP BOOM

195,000 lb + 64,000 lb CB

360°

ANSI B 30.5

220' (67.1 m) Boom length			
Radius (Feet)	Boom Angle (Degrees)	360 Degree Rating (Pounds)	From Boom Pt. to Ground (Feet)
37	82.0	156,330 *	225
40	81.2	156,330 *	225
50	78.5	136,180	223
60	75.8	105,890	221
70	73.1	85,410	218
80	70.4	71,290	215
90	67.6	60,330	211
100	64.7	51,820	207
110	61.8	45,020	202
120	58.8	39,890	196
130	55.7	35,240	189
140	52.5	31,310	182
150	49.1	27,940	174
160	45.5	25,010	165
170	41.7	22,470	154
180	37.6	20,210	142
190	33.0	18,210	128
200	27.8	16,420	110
210	21.5	14,810	88
220	12.3	11,230 *	55

230' (70.1 m) Boom length			
Radius (Feet)	Boom Angle (Degrees)	360 Degree Rating (Pounds)	From Boom Pt. to Ground (Feet)
39	81.8	132,640 *	235
40	81.6	132,510 *	235
50	79.0	132,510 *	233
60	76.5	105,630	231
70	73.9	85,150	229
80	71.3	71,050	225
90	68.6	60,080	222
100	65.9	51,570	218
110	63.1	44,770	213
120	60.3	39,670	207
130	57.4	35,020	201
140	54.4	31,090	195
150	51.2	27,720	187
160	47.9	24,800	178
170	44.5	22,250	169
180	40.7	20,000	158
190	36.7	18,000	145
200	32.3	16,200	131
210	27.2	14,600	113
220	21.0	13,150	90
230	12.1	9,440 *	56

240' (73.2 m) Boom length			
Radius (Feet)	Boom Angle (Degrees)	360 Degree Rating (Pounds)	From Boom Pt. to Ground (Feet)
40	81.9	119,340 *	245
50	79.5	119,340 *	244
60	77.1	105,180	242
70	74.6	84,680	239
80	72.1	70,590	236
90	69.6	59,620	233
100	67.0	51,100	229
110	64.3	44,290	224
120	61.7	39,210	219
130	58.9	34,560	213
140	56.1	30,620	207
150	53.1	27,260	200
160	50.0	24,340	192
170	46.8	21,780	183
180	43.5	19,520	173
190	39.8	17,520	161
200	35.9	15,730	148
210	31.6	14,130	133
220	26.6	12,680	115
230	20.6	10,860 *	92
240	11.8	7,380 *	57

250' (76.2 m) Boom length			
Radius (Feet)	Boom Angle (Degrees)	360 Degree Rating (Pounds)	From Boom Pt. to Ground (Feet)
42	81.8	117,270 *	255
50	79.9	117,270 *	254
60	77.6	104,710	252
70	75.2	84,180	249
80	72.8	70,100	247
90	70.4	59,120	243
100	67.9	50,590	239
110	65.4	43,770	235
120	62.9	38,720	230
130	60.3	34,060	225
140	57.6	30,130	219
150	54.8	26,750	212
160	52.0	23,830	205
170	49.0	21,270	196
180	45.8	19,010	187
190	42.5	17,020	177
200	39.0	15,220	165
210	35.2	13,610	152
220	30.9	12,160	136
230	26.1	10,830	117
240	20.1	8,560 *	94
250	11.5	5,360 *	58



WITH 92HI OFFSET TIP BOOM

195,000 lb + 64,000 lb CB

360°

ANSI B 30.5

260' (79.2 m) Boom length			
Radius (Feet)	Boom Angle (Degrees)	360 Degree Rating (Pounds)	From Boom Pt. to Ground (Feet)
43	81.9	107,130 *	265
50	80.3	107,130 *	264
60	78.1	104,250	262
70	75.8	83,700	260
80	73.5	69,630	257
90	71.2	58,640	254
100	68.8	50,110	250
110	66.4	43,280	246
120	64.0	38,240	241
130	61.5	33,590	236
140	59.0	29,650	230
150	56.4	26,270	224
160	53.7	23,350	217
170	50.9	20,790	209
180	48.0	18,530	201
190	44.9	16,530	191
200	41.7	14,740	180
210	38.2	13,120	168
220	34.5	11,670	155
230	30.3	10,340	139

290' (88.4 m) Boom length			
Radius (Feet)	Boom Angle (Degrees)	360 Degree Rating (Pounds)	From Boom Pt. to Ground (Feet)
47	81.9	76,270 *	295
50	81.3	75,930 *	294
60	79.3	75,260 *	293
70	77.3	73,930 *	291
80	75.3	68,390	288
90	73.2	57,390	285
100	71.1	48,840	282
110	69.0	42,000	278
120	66.9	37,040	274
130	64.7	32,370	270
140	62.5	28,420	265
150	60.2	25,040	259
160	57.9	22,120	253
170	55.6	19,550	247
180	53.1	17,290	240
190	50.6	15,290	232
200	48.0	13,490	223
210	45.3	11,880	214
220	42.4	10,410	203
230	39.3	9,090	191

270' (82.3 m) Boom length			
Radius (Feet)	Boom Angle (Degrees)	360 Degree Rating (Pounds)	From Boom Pt. to Ground (Feet)
44	82.0	98,020 *	275
50	80.7	98,020 *	274
60	78.5	97,710 *	272
70	76.3	83,220	270
80	74.1	69,150	267
90	71.9	58,160	264
100	69.7	49,620	261
110	67.4	42,790	257
120	65.1	37,770	252
130	62.7	33,110	248
140	60.3	29,170	242
150	57.8	25,790	236
160	55.2	22,860	229
170	52.6	20,300	222
180	49.8	18,050	214
190	47.0	16,040	205
200	44.0	14,240	195
210	40.8	12,630	184
220	37.5	11,180	172
230	33.8	9,850	158

300' (91.4 m) Boom length			
Radius (Feet)	Boom Angle (Degrees)	360 Degree Rating (Pounds)	From Boom Pt. to Ground (Feet)
49	81.8	74,730 *	305
50	81.6	74,730 *	304
60	79.7	73,910 *	303
70	77.7	72,390 *	301
80	75.8	67,920	298
90	73.8	56,900	296
100	71.8	48,330	293
110	69.7	41,490	289
120	67.7	36,540	285
130	65.6	31,870	281
140	63.5	27,920	276
150	61.3	24,540	271
160	59.1	21,610	265
170	56.9	19,040	259
180	54.5	16,780	252
190	52.2	14,780	245
200	49.7	12,980	236
210	47.1	11,360	227
220	44.4	9,900	218
230	41.6	8,570	207

280' (85.3 m) Boom length			
Radius (Feet)	Boom Angle (Degrees)	360 Degree Rating (Pounds)	From Boom Pt. to Ground (Feet)
46	81.8	84,470 *	285
50	81.0	84,270 *	284
60	78.9	83,540 *	282
70	76.8	82,110 *	280
80	74.7	68,850	278
90	72.6	57,860	275
100	70.4	49,310	271
110	68.2	42,480	268
120	66.0	37,490	263
130	63.7	32,830	259
140	61.4	28,900	254
150	59.1	25,510	248
160	56.6	22,580	242
170	54.1	20,030	235
180	51.6	17,770	227
190	48.9	15,760	219
200	46.1	13,970	209
210	43.2	12,350	199
220	40.1	10,900	188
230	36.7	9,580	175

NOTES TO LIFTING CAPACITY

⚠ Warning

This rating chart is invalid if the crane has been modified or altered by use of other than GENUINE AMERICAN PARTS as such modifications or alterations may affect its capacity or safe operation. See American Crane Corporation Service Bulletin #259.

Ratings in this chart are in POUNDS and do not exceed the percentage of tipping specified for this crane by ANSI B30.5. All ratings require that the crane be standing level on a firm uniformly supporting surface.

Do not lift loads in excess of those shown on this chart. Lifting loads in excess of those shown or operation not in accordance with good operating practice, including limitations shown on page 3499 of Operator's Manual, can cause tipping, structural damage or catastrophic failure.

Asterisk (*) areas on this chart indicate ratings that are limited by strength of material or factors other than stability (tipping).

„RADIUS IN FEET“ is the horizontal distance at ground level from the crane centerline of rotation to a vertical line through the center of gravity of the suspended load.

When using the main boom fall with jib in place, the main fall ratings must be reduced by the jib effective weight shown on the jib rating chart plus twice the weight of all suspended blocks, slings, rope, etc., at the jib fall. See Appendix A.

When using the main boom fall with boom tip extension in place, the main fall ratings must be reduced by the weight of the boom tip extension plus twice the weight of all suspended blocks, slings, rope, etc., at the boom tip extension fall. See Appendix A.

Blocks, slings, buckets and other load carrying devices are considered part of the load. The weight of standard hoisting ropes for the rating at a given radius has been calculated as part of the boom point load and need not be considered in determining net allowable loads. See Appendix A.

This chart was developed exclusively for use with a boom only. Under no circumstances are these ratings to be interpreted for use with a jib.

Ratings shown on this chart make no allowance for such factors as out of plumb loads, wind, poor soil conditions, improper inflation of rubber tires and dynamic effects due to excessive operating speeds. The user (operator) must exercise judgment to make allowance for these conditions. See page 3499 of Operator's Manual for detailed information.

No account is taken of the wind force on the load. The user must consider this effect, which can be substantial for loads with large surface areas. In any wind it is strongly recommended that taglines be used to control the load.

BOOM HOIST LINE is 18 parts of 7/8 inch diameter 6 x 26, WS, FW, RAL, IWRC, EIPS wire rope with a minimum breaking strength of 79,600 pounds.

BOOM PENDANT SUSPENSION is 4 parts of 1-3/8 inch diameter EEIPS wire rope with a minimum breaking strength of 211,000 pounds.

MAIN LOAD LINE is 1-1/8 inch diameter 6 x 25, FW, RRL, IWRC, EEIPS wire rope with a minimum breaking strength of 143,000 pounds.

ERECTION

Erection „BLOCKED OVER THE END“ is with the boom over the idler end with idler tumblers blocked (See operator's manual for blocking instructions).

Erection „OVER THE SIDE“ is with the boom 90° to the side frames. Blocks, slings and other load carrying devices must be on the ground during erection.

92HI OFFSET TIP BOOM MAXIMUM BOOM & JIB SELF-ERECTION DATA				
	BOOM LENGTH (FEET)	JIB LENGTH		
		16HL JIB (FEET)	#30 JIB (FEET)	#40 JIB (FEET)
BLOCKED OVER THE END	300	50	0	0
	290	100	0	45
	280		65	75
	270		95	105
OVER THE SIDE	280	0	0	0
	270	70	0	0
	260	100	35	45
	250		65	75
	240		95	105

BOOM COMPOSITION CHART - 92HI OFFSET TIP						
BOOM LENGTH (FEET)	BOOM SECTIONS					
	25' 92HI INNER	15' 92HT CENTER	20' 92HT CENTER	10' 92ST CENTER	50' 92ST CENTER	40' 92H OUTER
65 ¹	1	0	0	0	0	1
80	1	1	0	0	0	1
90	1	1	0	1	0	1
100	1	1	1	0	0	1
110	1	1	1	1	0	1
120	1	1	1	2	0	1
130	1	1	0	0	1	1
140	1	1	0	1	1	1
150	1	1	1	0	1	1
160	1	1	1	1	1	1
170	1	1	1	2	1	1
180	1	1	0	0	2	1
190	1	1	0	1	2	1
200	1	1	1	0	2	1
210	1	1	1	1	2	1
220	1	1	1	2	2	1
230	1	1	0	0	3	1
240	1	1	0	1	3	1
250	1	1	1	0	3	1
260	1	1	1	1	3	1
270	1	1	1	2	3	1
280	1	1	0	0	4	1
290	1	1	0	1	4	1
300	1	1	1	0	4	1

LOAD HOISTING INFORMATION - 1-1/8 inch diameter EEIPS wire rope			
MAXIMUM LIFTING CAPACITY - LBS.	MINIMUM PARTS OF LINE	MAXIMUM HOISTING DISTANCE - FEET	
		MAIN HOIST	AUX HOIST
550,000 ¹	14	90	90
490,280	12	105	105
449,420	11	110	110
408,570	10	130	130
367,710	9	145	145
326,850	8	160	160
286,000	7	185	185
245,140	6	215	215
204,280	5	260	260
163,420	4	325	325
122,570	3	435	435
81,710	2	655	655
40,850	1	1,310	1,310

¹ Lifting any load with 14 parts of main fall load line requires the use of the single sheave crossover hanger block. Refer to the HC 275 Operator's Manual for detailed information

RANGE DIAGRAM, #30 JIB

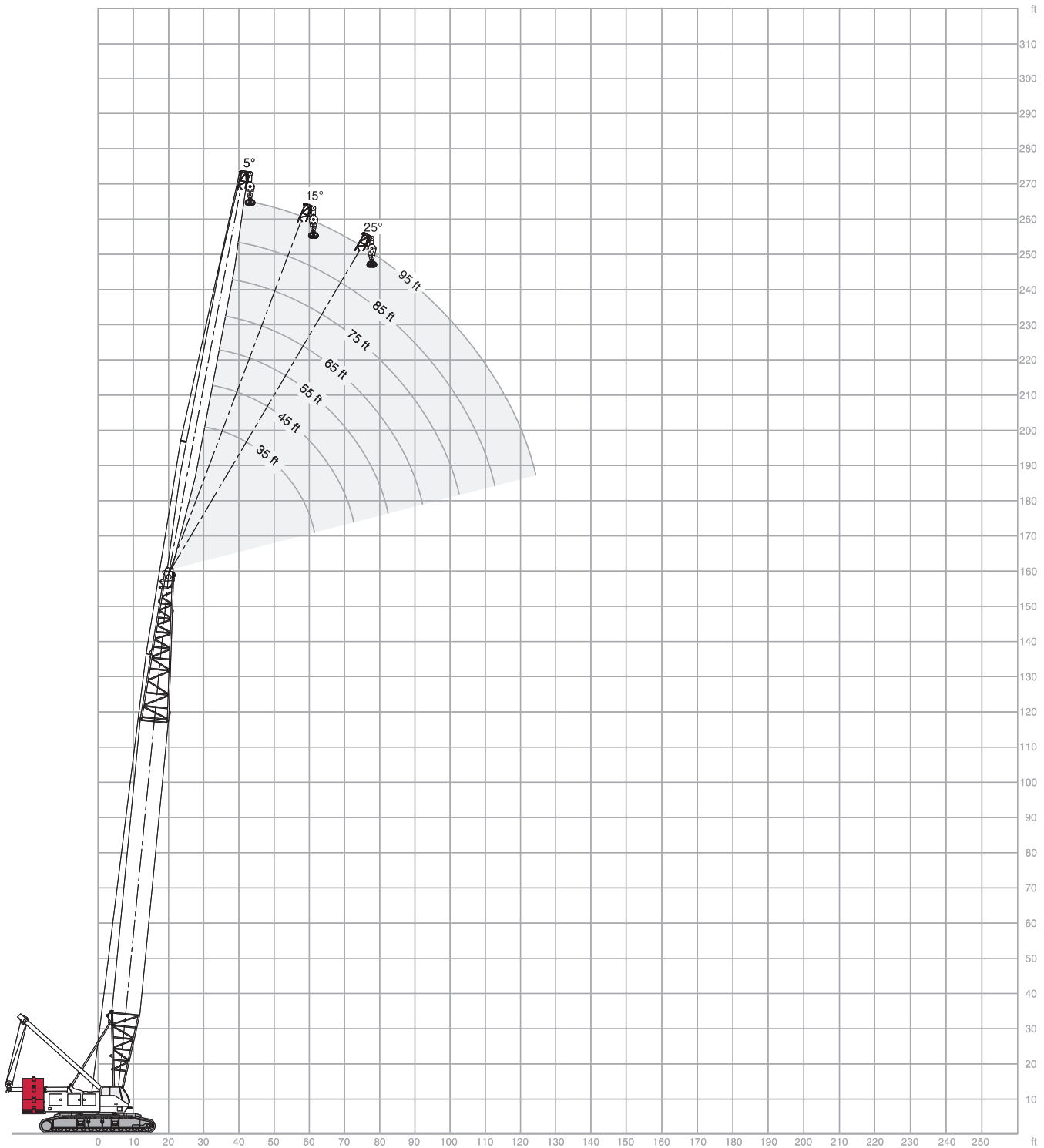

WITH 92HI OFFSET TIP BOOM, # 30 JIB

195,000 lb + 64,000 lb CB

360°

ANSI B 30.5

35' (10.7 m) Jib length

Boom length	Jib Radius (Feet)	5.0 Deg offset		15.0 Deg offset		25.0 Deg offset	
		Boom Angle	Rating (Pounds)	Boom Angle	Rating (Pounds)	Boom Angle	Rating (Pounds)
	27	81.6	60,000*	-	-	-	-
	30	80.2	60,000*	-	-	-	-
	35	77.9	60,000*	80.6	60,000*	-	-
	40	75.6	60,000*	78.2	60,000*	80.7	60,000*
90' (27.4 m)	50	70.9	60,000*	73.5	60,000*	75.9	54,780*
	60	65.9	60,000*	68.5	60,000*	70.9	48,790*
	70	60.8	60,000*	63.4	57,480*	65.6	44,090*
	80	55.4	60,000*	57.9	51,220*	60.1	40,500*
	90	49.6	54,310*	52.1	46,420*	54.1	40,500*

	28	81.8	60,000*	-	-	-	-
	30	81.0	60,000*	-	-	-	-
	35	78.8	60,000*	81.3	60,000*	-	-
	40	76.7	60,000*	79.1	60,000*	81.4	60,000*
100' (30.5 m)	50	72.3	60,000*	74.7	60,000*	77.0	57,490*
	60	67.8	60,000*	70.2	60,000*	72.4	51,390*
	70	63.2	60,000*	65.5	60,000*	67.7	46,570*
	80	58.3	60,000*	60.6	55,050*	62.7	42,660*
	90	53.2	57,900*	55.4	49,710*	57.4	40,590*
	100	47.6	52,440*	49.8	45,540*	51.7	40,470*

	29	82.0	60,000*	-	-	-	-
	30	81.6	60,000*	-	-	-	-
	35	79.6	60,000*	81.9	60,000*	-	-
	40	77.6	60,000*	79.9	60,000*	-	-
110' (33.5 m)	50	73.6	60,000*	75.8	60,000*	77.9	59,740*
	60	69.4	60,000*	71.7	60,000*	73.7	53,610*
	70	65.1	60,000*	67.4	60,000*	69.4	48,670*
	80	60.7	60,000*	62.9	57,340*	64.8	44,800*
	90	56.1	60,000*	58.2	52,700*	60.1	41,640*
	100	51.2	55,730*	53.3	48,500*	55.0	40,580*
	110	45.8	50,180	47.9	44,930*	49.5	40,570*

	31	81.7	60,000*	-	-	-	-
	35	80.3	60,000*	-	-	-	-
	40	78.4	60,000*	80.5	60,000*	-	-
	50	74.6	60,000*	76.8	60,000*	78.7	59,980*
120' (36.6 m)	60	70.8	60,000*	72.9	60,000*	74.8	55,680*
	70	66.8	60,000*	68.9	60,000*	70.8	50,810*
	80	62.8	60,000*	64.8	59,790*	66.7	46,830*
	90	58.5	60,000*	60.6	54,840*	62.3	43,490*
	100	54.1	56,360	56.1	50,840*	57.8	40,660*
	110	49.3	49,620	51.3	47,470*	52.9	40,440*
	120	44.2	44,120	46.1	44,120	47.6	40,440*

	32	81.9	60,000*	-	-	-	-
	35	80.9	60,000*	-	-	-	-
	40	79.1	60,000*	81.1	60,000*	-	-
	50	75.6	60,000*	77.6	60,000*	79.4	59,930*
130' (39.6 m)	60	72.0	60,000*	74.0	60,000*	75.8	57,570*
	70	68.3	60,000*	70.3	60,000*	72.1	52,530*
	80	64.5	60,000*	66.5	60,000*	68.2	48,500*
	90	60.6	60,000*	62.5	56,870*	64.2	45,100*
	100	56.6	56,170	58.4	52,750*	60.1	42,420*
	110	52.3	49,430	54.1	49,430*	55.7	40,540*
	120	47.7	43,920	49.5	43,920	51.0	40,510*
	130	42.8	39,590	44.5	39,590	45.9	39,600

Boom length	Jib Radius (Feet)	5.0 Deg offset		15.0 Deg offset		25.0 Deg offset	
		Boom Angle	Rating (Pounds)	Boom Angle	Rating (Pounds)	Boom Angle	Rating (Pounds)
	34	81.7	60,000*	-	-	-	-
	35	81.4	60,000*	-	-	-	-
	40	79.7	60,000*	81.6	60,000*	-	-
	50	76.4	60,000*	78.3	60,000*	80.1	59,880*
	60	73.0	60,000*	74.9	60,000*	76.6	59,120*
	70	69.6	60,000*	71.5	60,000*	73.2	54,310*
140' (42.7 m)	80	66.1	60,000*	67.9	60,000*	69.6	50,140*
	90	62.5	60,000*	64.3	58,990*	65.9	46,770*
	100	58.7	55,630	60.5	54,650*	62.1	43,920*
	110	54.8	48,890	56.5	48,890	58.0	41,540*
	120	50.6	43,380	52.4	43,380	53.8	40,500*
	130	46.2	39,080	47.9	39,080	49.3	39,090
	140	41.5	35,180	43.1	35,190	44.4	35,190

	35	81.8	60,000*	-	-	-	-
	40	80.3	60,000*	-	-	-	-
	50	77.2	60,000*	78.9	60,000*	80.6	59,830*
	60	74.0	60,000*	75.8	60,000*	77.4	59,830*
	70	70.7	60,000*	72.5	60,000*	74.1	55,810*
	80	67.4	60,000*	69.2	60,000*	70.8	51,710*
150' (45.7 m)	90	64.1	60,000*	65.8	60,000*	67.3	48,280*
	100	60.6	55,040	62.3	55,050	63.8	45,280*
	110	56.9	48,290	58.6	48,300	60.1	42,810*
	120	53.2	42,780	54.8	42,780	56.2	40,680*
	130	49.2	38,500	50.8	38,510	52.1	38,510
	140	44.9	34,610	46.5	34,610	47.7	34,620
	150	40.3	31,270	41.8	31,280	43.0	31,280

	36	82.0	60,000*	-	-	-	-
	40	80.8	60,000*	-	-	-	-
	50	77.8	60,000*	79.5	60,000*	81.1	59,790*
	60	74.8	60,000*	76.5	60,000*	78.1	59,790*
	70	71.8	60,000*	73.4	60,000*	75.0	57,170*
	80	68.7	60,000*	70.3	60,000*	71.8	53,180*
160' (48.8 m)	90	65.5	60,000*	67.1	60,000*	68.6	49,740*
	100	62.2	54,500	63.8	54,500	65.3	46,770*
	110	58.8	47,750	60.4	47,750	61.8	44,080*
	120	55.3	42,230	56.9	42,230	58.3	42,020*
	130	51.7	37,980	53.2	37,990	54.5	37,990
	140	47.8	34,080	49.3	34,090	50.6	34,090
	150	43.7	30,740	45.1	30,740	46.3	30,750
	160	39.2	27,850	40.6	27,850	41.7	27,860

	38	81.8	60,000*	-	-	-	-
	40	81.2	60,000*	-	-	-	-
	50	78.4	60,000*	80.0	60,000*	81.6	59,740*
	60	75.6	60,000*	77.2	60,000*	78.7	59,740*
	70	72.7	60,000*	74.3	60,000*	75.7	58,720*
	80	69.7	60,000*	71.3	60,000*	72.8	54,390*
170' (51.8 m)	90	66.7	60,000*	68.3	60,000*	69.7	50,960*
	100	63.7	53,950	65.2	53,960	66.6	48,100*
	110	60.5	47,190	62.0	47,200	63.4	45,420*
	120	57.2	41,670	58.8	41,670	60.1	41,680
	130	53.8	37,450	55.3	37,460	56.6	37,460
	140	50.3	33,540	51.8	33,550	53.0	33,550
	150	46.5	30,200	48.0	30,210	49.1	30,210
	160	42.5	27,310	43.9	27,310	45.0	27,320
	170	38.2	24,780	39.5	24,780	40.5	24,790

3

WITH 92HI OFFSET TIP BOOM, #30 JIB

195,000 lb + 64,000 lb CB

360°

ANSI B 30.5

35' (10.7 m) Jib length

Boom length	Jib Radius (Feet)	5.0 Deg offset		15.0 Deg offset		25.0 Deg offset	
		Boom Angle	Rating (Pounds)	Boom Angle	Rating (Pounds)	Boom Angle	Rating (Pounds)
	39	81.9	60,000*	-	-	-	-
	40	81.6	60,000*	-	-	-	-
	50	79.0	60,000*	80.5	60,000*	82.0	59,690*
	60	76.2	60,000*	77.8	60,000*	79.2	59,690*
	70	73.5	60,000*	75.0	60,000*	76.4	59,690*
	80	70.7	60,000*	72.2	60,000*	73.6	55,740*
180' (54.9 m)	90	67.9	60,000*	69.4	60,000*	70.7	52,200*
	100	65.0	53,670	66.5	53,680	67.8	49,170*
	110	62.0	46,910	63.5	46,910	64.8	46,550*
	120	58.9	41,380	60.4	41,390	61.7	41,400
	130	55.8	37,200	57.2	37,200	58.4	37,200
	140	52.5	33,290	53.9	33,300	55.1	33,300
	150	49.0	29,950	50.4	29,960	51.5	29,960
	160	45.4	27,050	46.7	27,060	47.8	27,060
	170	41.5	24,520	42.8	24,520	43.8	24,530
	180	37.2	22,290	38.5	22,290	39.4	22,300

	41	81.8	60,000*	-	-	-	-
	50	79.5	60,000*	80.9	60,000*	-	-
	60	76.9	60,000*	78.3	60,000*	79.7	59,650*
	70	74.3	60,000*	75.7	60,000*	77.1	59,650*
	80	71.6	60,000*	73.0	60,000*	74.4	56,860*
	90	68.9	60,000*	70.3	60,000*	71.6	53,380*
190' (57.9 m)	100	66.2	53,140	67.6	53,140	68.9	50,340*
	110	63.3	46,380	64.8	46,390	66.0	46,400
	120	60.5	40,850	61.9	40,850	63.1	40,860
	130	57.5	36,690	58.9	36,690	60.1	36,690
	140	54.4	32,780	55.8	32,790	56.9	32,790
	150	51.2	29,440	52.5	29,440	53.7	29,450
	160	47.8	26,540	49.2	26,540	50.2	26,550
	170	44.3	24,010	45.6	24,010	46.6	24,010
	180	40.5	21,770	41.7	21,780	42.7	21,780
	190	36.3	19,790	37.5	19,800	38.4	19,800

	42	81.9	60,000*	-	-	-	-
	50	79.9	60,000*	81.3	60,000*	-	-
	60	77.4	60,000*	78.8	60,000*	80.2	59,610*
	70	74.9	60,000*	76.3	60,000*	77.6	59,610*
	80	72.4	60,000*	73.8	60,000*	75.1	58,090*
	90	69.8	60,000*	71.2	60,000*	72.5	54,450*
	100	67.2	52,580	68.6	52,580	69.8	51,420*
	110	64.6	45,810	65.9	45,820	67.1	45,820
200' (61.0 m)	120	61.8	40,280	63.2	40,280	64.4	40,290
	130	59.0	36,140	60.4	36,140	61.5	36,150
	140	56.1	32,230	57.5	32,240	58.6	32,240
	150	53.1	28,880	54.4	28,880	55.5	28,890
	160	50.0	25,980	51.3	25,980	52.3	25,990
	170	46.8	23,440	48.0	23,450	49.0	23,450
	180	43.3	21,210	44.5	21,210	45.4	21,220
	190	39.6	19,220	40.8	19,230	41.6	19,230
	200	35.5	17,460	36.7	17,460	37.4	17,470

Boom length	Jib Radius (Feet)	5.0 Deg offset		15.0 Deg offset		25.0 Deg offset	
		Boom Angle	Rating (Pounds)	Boom Angle	Rating (Pounds)	Boom Angle	Rating (Pounds)
	43	82.0	60,000*	-	-	-	-
	50	80.3	60,000*	81.7	60,000*	-	-
	60	78.0	60,000*	79.3	60,000*	80.6	59,560*
	70	75.6	60,000*	76.9	60,000*	78.2	59,560*
	80	73.1	60,000*	74.5	60,000*	75.7	59,040*
	90	70.7	60,000*	72.0	60,000*	73.2	55,630*
	100	68.2	52,040	69.5	52,040	70.7	52,050
	110	65.7	45,270	67.0	45,270	68.1	45,280
210' (64.0 m)	120	63.1	40,240	64.4	40,240	65.5	40,250
	130	60.4	35,620	61.7	35,620	62.8	35,630
	140	57.7	31,710	59.0	31,710	60.1	31,710
	150	54.9	28,360	56.1	28,360	57.2	28,370
	160	52.0	25,460	53.2	25,460	54.2	25,470
	170	48.9	22,920	50.1	22,920	51.1	22,930
	180	45.7	20,680	46.9	20,690	47.9	20,690
	190	42.3	18,700	43.5	18,700	44.4	18,710
	200	38.7	16,920	39.8	16,920	40.7	16,930
	210	34.8	15,330	35.8	15,330	36.6	15,340

	45	81.8	60,000*	-	-	-	-
	50	80.7	60,000*	-	-	-	-
	60	78.4	60,000*	79.7	60,000*	80.9	59,510*
	70	76.1	60,000*	77.4	60,000*	78.6	59,510*
	80	73.8	60,000*	75.1	60,000*	76.3	59,510*
	90	71.5	59,980	72.8	59,980	73.9	56,550*
	100	69.1	51,510	70.4	51,510	71.5	51,520
	110	66.7	44,730	67.9	44,730	69.1	44,740
220' (67.1 m)	120	64.2	39,720	65.5	39,720	66.6	39,730
	130	61.7	35,090	62.9	35,100	64.0	35,100
	140	59.1	31,180	60.3	31,180	61.4	31,190
	150	56.5	27,830	57.7	27,840	58.7	27,840
	160	53.7	24,930	54.9	24,930	55.9	24,940
	170	50.9	22,390	52.0	22,390	53.0	22,400
	180	47.9	20,150	49.0	20,150	50.0	20,160
	190	44.8	18,160	45.9	18,170	46.8	18,170
	200	41.5	16,390	42.6	16,390	43.4	16,400
	210	37.9	14,790	39.0	14,790	39.7	14,800
	220	34.0	13,350	35.1	13,350	35.7	13,360

	46	81.9	60,000*	-	-	-	-
	50	81.1	60,000*	-	-	-	-
	60	78.9	60,000*	80.1	60,000*	81.3	59,460*
	70	76.7	60,000*	77.9	60,000*	79.1	59,460*
	80	74.4	60,000*	75.7	60,000*	76.8	59,460*
	90	72.2	59,650	73.4	59,660	74.6	57,630*
	100	69.9	51,170	71.1	51,170	72.2	51,180
	110	67.6	44,400	68.8	44,400	69.9	44,410
230' (70.1 m)	120	65.3	39,410	66.5	39,410	67.5	39,410
	130	62.9	34,790	64.0	34,790	65.1	34,800
	140	60.4	30,870	61.6	30,870	62.6	30,880
	150	57.9	27,530	59.0	27,530	60.0	27,530
	160	55.3	24,620	56.4	24,620	57.4	24,630
	170	52.6	22,080	53.7	22,080	54.7	22,090
	180	49.8	19,850	50.9	19,850	51.9	19,860
	190	46.9	17,860	48.0	17,860	48.9	17,870
	200	43.9	16,080	44.9	16,090	45.8	16,090
	210	40.6	14,480	41.7	14,480	42.5	14,490
	220	37.1	13,040	38.2	13,040	38.9	13,050
	230	33.4	11,730	34.3	11,740	35.0	11,750

WITH 92HI OFFSET TIP BOOM, # 30 JIB

195,000 lb + 64,000 lb CB

360°

ANSI B 30.5

35' (10.7 m) Jib length

Boom length	Jib Radius (Feet)	5.0 Deg offset		15.0 Deg offset		25.0 Deg offset	
		Boom Angle	Rating (Pounds)	Boom Angle	Rating (Pounds)	Boom Angle	Rating (Pounds)
	48	81.8	60,000*	-	-	-	-
	50	81.4	60,000*	-	-	-	-
	60	79.3	60,000*	80.5	60,000*	81.6	59,410*
	70	77.2	60,000*	78.4	60,000*	79.5	59,410*
	80	75.0	60,000*	76.2	60,000*	77.3	59,410*
	90	72.9	59,140	74.0	59,150	75.1	58,430*
	100	70.7	50,650	71.9	50,650	72.9	50,660
	110	68.5	43,870	69.6	43,870	70.7	43,880
	120	66.2	38,910	67.4	38,910	68.4	38,920
	130	63.9	34,280	65.1	34,280	66.1	34,290
240' (73.2 m)	140	61.6	30,360	62.7	30,370	63.7	30,370
	150	59.2	27,020	60.3	27,020	61.3	27,030
	160	56.7	24,110	57.8	24,120	58.8	24,120
	170	54.2	21,570	55.3	21,570	56.2	21,580
	180	51.6	19,330	52.7	19,330	53.6	19,340
	190	48.8	17,340	49.9	17,340	50.8	17,350
	200	46.0	15,560	47.1	15,560	47.9	15,570
	210	43.0	13,960	44.1	13,970	44.8	13,970
	220	39.8	12,520	40.9	12,520	41.6	12,530
	230	36.4	11,210	37.4	11,220	38.1	11,220
	240	32.7	10,020	33.7	10,020	34.3	10,030

	49	81.9	60,000*	-	-	-	-
	50	81.7	60,000*	-	-	-	-
	60	79.7	60,000*	80.8	60,000*	81.9	59,370*
	70	77.6	60,000*	78.8	60,000*	79.9	59,370*
	80	75.6	60,000*	76.7	60,000*	77.8	59,370*
	90	73.5	58,590	74.6	58,600	75.7	58,610
	100	71.4	50,110	72.5	50,110	73.6	50,120
	110	69.2	43,320	70.4	43,320	71.4	43,330
	120	67.1	38,370	68.2	38,380	69.2	38,380
	130	64.9	33,750	66.0	33,750	67.0	33,750
250' (76.2 m)	140	62.7	29,830	63.8	29,830	64.7	29,830
	150	60.4	26,470	61.5	26,470	62.4	26,480
	160	58.0	23,560	59.1	23,570	60.0	23,570
	170	55.6	21,020	56.7	21,020	57.6	21,030
	180	53.1	18,780	54.2	18,780	55.1	18,790
	190	50.6	16,790	51.6	16,790	52.5	16,800
	200	47.9	15,010	49.0	15,010	49.8	15,020
	210	45.1	13,410	46.2	13,410	46.9	13,420
	220	42.2	11,970	43.2	11,970	44.0	11,980
	230	39.1	10,650	40.1	10,660	40.8	10,660
	240	35.8	9,450	36.7	9,460	37.3	9,470
	250	32.1	8,370	33.0	8,370	33.6	8,380

Boom length	Jib Radius (Feet)	5.0 Deg offset		15.0 Deg offset		25.0 Deg offset	
		Boom Angle	Rating (Pounds)	Boom Angle	Rating (Pounds)	Boom Angle	Rating (Pounds)
	50	82.0	60,000*	-	-	-	-
	60	80.0	60,000*	81.1	60,000*	-	-
	70	78.0	60,000*	79.2	60,000*	80.2	55,290*
	80	76.1	60,000*	77.2	59,240*	78.2	53,860*
	90	74.1	58,070	75.2	56,620*	76.2	52,050*
	100	72.0	49,580	73.1	49,580	74.1	49,590
	110	70.0	42,780	71.1	42,790	72.1	42,800
	120	67.9	37,870	69.0	37,870	70.0	37,880
	130	65.8	33,230	66.9	33,230	67.8	33,240
	140	63.7	29,310	64.7	29,310	65.7	29,320
260' (79.2 m)	150	61.5	25,950	62.5	25,960	63.5	25,960
	160	59.2	23,050	60.3	23,050	61.2	23,050
	170	56.9	20,500	58.0	20,500	58.9	20,510
	180	54.6	18,260	55.6	18,260	56.5	18,270
	190	52.2	16,270	53.2	16,270	54.0	16,270
	200	49.7	14,490	50.7	14,490	51.5	14,490
	210	47.0	12,880	48.0	12,880	48.8	12,890
	220	44.3	11,430	45.3	11,430	46.0	11,440
	230	41.4	10,120	42.4	10,120	43.1	10,130
	240	38.4	8,930	39.3	8,930	40.0	8,940
	250	35.1	7,840	36.0	7,840	36.6	7,850
	260	31.5	6,830	32.4	6,840	32.9	6,850

	52	81.8	60,000*	-	-	-	-
	60	80.3	60,000*	81.4	57,380*	-	-
	70	78.4	60,000*	79.5	54,860*	80.5	49,420*
	80	76.5	57,190*	77.6	52,360*	78.6	47,740*
	90	74.6	54,310*	75.7	50,160*	76.7	46,120*
	100	72.6	49,050	73.7	47,880*	74.7	44,480*
	110	70.7	42,250	71.7	42,250	72.7	42,260
	120	68.7	37,350	69.7	37,360	70.7	37,360
	130	66.6	32,710	67.7	32,720	68.6	32,720
	140	64.6	28,790	65.6	28,800	66.5	28,800
270' (82.3 m)	150	62.5	25,430	63.5	25,430	64.4	25,430
	160	60.3	22,520	61.4	22,520	62.3	22,530
	170	58.2	19,970	59.2	19,980	60.0	19,980
	180	55.9	17,730	56.9	17,730	57.8	17,740
	190	53.6	15,740	54.6	15,740	55.4	15,750
	200	51.2	13,960	52.2	13,960	53.0	13,960
	210	48.8	12,350	49.7	12,350	50.5	12,350
	220	46.2	10,900	47.2	10,900	47.9	10,910
	230	43.5	9,590	44.5	9,590	45.2	9,600
	240	40.7	8,390	41.6	8,390	42.3	8,400
	250	37.7	7,300	38.6	7,300	39.3	7,310
	260	34.5	6,290	35.4	6,290	35.9	6,300
	270	31.0	5,260*	31.8	5,370	32.3	5,380

3

WITH 92HI OFFSET TIP BOOM, #30 JIB

195,000 lb + 64,000 lb CB

360°

ANSI B 30.5

45' (13.7 m) Jib length

Boom length	Jib Radius (Feet)	5.0 Deg offset		15.0 Deg offset		25.0 Deg offset	
		Boom Angle	Rating (Pounds)	Boom Angle	Rating (Pounds)	Boom Angle	Rating (Pounds)
	33	81.9	60,000*	-	-	-	-
	35	81.2	60,000*	-	-	-	-
	40	79.4	60,000*	-	-	-	-
	50	75.9	60,000*	78.5	60,000*	80.9	46,910*
120' (36.6 m)	60	72.3	60,000*	74.8	60,000*	77.2	44,510*
	70	68.6	60,000*	71.1	55,020*	73.5	40,630*
	80	64.8	60,000*	67.3	49,340*	69.6	40,350*
	90	60.9	55,330*	63.4	44,790*	65.6	39,130*
	100	56.9	50,040*	59.3	41,060*	61.5	36,220*
	110	52.6	45,790*	55.0	40,210*	57.1	33,990*
	120	48.0	42,120*	50.4	37,680*	52.3	32,040*

	34	82.0	60,000*	-	-	-	-
	35	81.7	60,000*	-	-	-	-
	40	80.0	60,000*	-	-	-	-
	50	76.7	60,000*	79.1	60,000*	81.4	46,860*
130' (39.6 m)	60	73.3	60,000*	75.7	60,000*	78.0	45,890*
	70	69.9	60,000*	72.3	57,350*	74.5	41,970*
	80	66.4	60,000*	68.7	51,500*	70.9	40,450*
	90	62.7	58,140*	65.1	46,780*	67.2	40,380*
	100	59.0	52,630*	61.3	42,900*	63.4	37,690*
	110	55.1	48,180*	57.3	40,450*	59.3	35,290*
	120	50.9	44,190	53.2	39,230*	55.1	33,380*
	130	46.5	39,890	48.7	36,970*	50.5	31,670*

	36	81.8	60,000*	-	-	-	-
	40	80.6	60,000*	-	-	-	-
	50	77.4	60,000*	79.7	60,000*	81.9	46,810*
	60	74.2	60,000*	76.5	60,000*	78.7	46,810*
140' (42.7 m)	70	71.0	60,000*	73.3	58,830*	75.4	43,110*
	80	67.7	60,000*	70.0	53,760*	72.0	40,370*
	90	64.3	60,000*	66.6	48,740*	68.6	40,370*
	100	60.8	55,100*	63.0	44,870*	65.0	39,110*
	110	57.2	49,140	59.4	41,530*	61.3	36,730*
	120	53.4	43,630	55.6	40,450*	57.4	34,610*
	130	49.4	39,360	51.5	38,330*	53.3	32,820*
	140	45.2	35,470	47.2	35,470	48.9	31,400*

	37	81.9	60,000*	-	-	-	-
	40	81.0	60,000*	-	-	-	-
	50	78.1	60,000*	80.3	60,000*	-	-
	60	75.1	60,000*	77.2	60,000*	79.3	46,780*
	70	72.0	60,000*	74.2	60,000*	76.2	44,210*
	80	68.9	60,000*	71.0	55,400*	73.0	40,860*
150' (45.7 m)	90	65.7	60,000*	67.8	50,630*	69.8	40,410*
	100	62.5	55,300	64.6	46,580*	66.4	40,350*
	110	59.1	48,550	61.2	43,130*	63.0	37,990*
	120	55.6	43,040	57.6	40,360*	59.4	35,890*
	130	51.9	38,790	53.9	38,800	55.6	33,940*
	140	48.0	34,890	50.0	34,900	51.7	32,410*
	150	43.9	31,560	45.8	31,560	47.4	31,130*

Boom length	Jib Radius (Feet)	5.0 Deg offset		15.0 Deg offset		25.0 Deg offset	
		Boom Angle	Rating (Pounds)	Boom Angle	Rating (Pounds)	Boom Angle	Rating (Pounds)
	39	81.8	60,000*	-	-	-	-
	40	81.5	60,000*	-	-	-	-
	50	78.7	60,000*	80.7	60,000*	-	-
	60	75.8	60,000*	77.9	60,000*	79.8	46,730*
	70	72.9	60,000*	75.0	60,000*	76.9	45,130*
	80	70.0	60,000*	72.0	56,820*	73.9	41,960*
160' (48.8 m)	90	67.0	60,000*	69.0	52,310*	70.8	40,390*
	100	63.9	54,750	65.9	48,260*	67.7	40,390*
	110	60.7	48,000	62.7	44,840*	64.5	39,200*
	120	57.5	42,470	59.4	41,820*	61.2	36,990*
	130	54.1	38,260	56.0	38,270	57.7	35,120*
	140	50.5	34,360	52.4	34,370	54.0	33,430*
	150	46.8	31,010	48.6	31,020	50.2	31,020
	160	42.8	28,120	44.6	28,120	46.0	28,130

	40	81.9	60,000*	-	-	-	-
	50	79.2	60,000*	81.2	60,000*	-	-
	60	76.5	60,000*	78.5	60,000*	80.3	46,680*
	70	73.7	60,000*	75.7	60,000*	77.5	46,060*
	80	70.9	60,000*	72.9	58,190*	74.7	42,830*
	90	68.1	60,000*	70.0	53,790*	71.8	40,130*
170' (51.8 m)	100	65.2	54,200	67.1	50,020*	68.9	40,130*
	110	62.2	47,440	64.1	46,330*	65.8	40,130*
	120	59.2	41,910	61.0	41,920	62.7	38,080*
	130	56.0	37,730	57.9	37,730	59.5	36,220*
	140	52.7	33,820	54.5	33,830	56.1	33,830
	150	49.3	30,480	51.1	30,490	52.5	30,490
	160	45.6	27,580	47.4	27,590	48.8	27,600
	170	41.7	25,050	43.4	25,050	44.7	25,060

	41	82.0	60,000*	-	-	-	-
	50	79.7	60,000*	81.6	60,000*	-	-
	60	77.1	60,000*	79.0	60,000*	80.8	46,630*
	70	74.5	60,000*	76.4	60,000*	78.1	46,630*
	80	71.8	60,000*	73.7	59,400*	75.4	43,800*
	90	69.1	60,000*	71.0	54,990*	72.7	41,060*
180' (54.9 m)	100	66.4	53,900	68.2	51,240*	69.9	40,250*
	110	63.6	47,140	65.4	47,150	67.0	40,250*
	120	60.7	41,620	62.5	41,630	64.1	39,120*
	130	57.7	37,460	59.5	37,460	61.0	37,130*
	140	54.6	33,550	56.4	33,560	57.9	33,560
	150	51.4	30,210	53.2	30,210	54.6	30,220
	160	48.1	27,310	49.8	27,320	51.2	27,320
	170	44.5	24,790	46.2	24,790	47.5	24,800
	180	40.7	22,550	42.3	22,560	43.6	22,560

	43	81.8	60,000*	-	-	-	-
	50	80.1	60,000*	81.9	60,000*	-	-
	60	77.6	60,000*	79.5	60,000*	81.2	46,580*
	70	75.1	60,000*	77.0	60,000*	78.6	46,580*
	80	72.6	60,000*	74.4	60,000*	76.1	44,560*
	90	70.0	60,000*	71.8	56,360*	73.5	41,830*
190' (57.9 m)	100	67.4	53,370	69.2	52,600*	70.8	40,230*
	110	64.8	46,600	66.5	46,610	68.1	40,230*
	120	62.0	41,080	63.8	41,080	65.3	40,020*
	130	59.2	36,940	61.0	36,940	62.5	36,950
	140	56.4	33,030	58.0	33,040	59.5	33,040
	150	53.4	29,690	55.0	29,690	56.5	29,700
	160	50.2	26,790	51.9	26,790	53.3	26,800
	170	47.0	24,260	48.6	24,270	49.9	24,270
	180	43.5	22,030	45.1	22,030	46.3	22,040
	190	39.8	20,040	41.3	20,050	42.5	20,060

WITH 92HI OFFSET TIP BOOM, #30 JIB

195,000 lb + 64,000 lb CB

360°

ANSI B 30.5

45' (13.7 m) Jib length

Boom length	Jib Radius (Feet)	5.0 Deg offset		15.0 Deg offset		25.0 Deg offset	
		Boom Angle	Rating (Pounds)	Boom Angle	Rating (Pounds)	Boom Angle	Rating (Pounds)
	44	81.9	60,000*	-	-	-	-
	50	80.5	60,000*	-	-	-	-
	60	78.2	60,000*	79.9	60,000*	81.5	46,540*
	70	75.8	60,000*	77.5	60,000*	79.1	46,540*
	80	73.3	60,000*	75.1	60,000*	76.7	45,340*
	90	70.9	60,000*	72.6	57,410*	74.2	42,660*
	100	68.4	52,810	70.1	52,810	71.6	40,320*
	110	65.9	46,030	67.6	46,030	69.1	40,200*
200' (61.0 m)	120	63.3	40,500	64.9	40,510	66.4	40,200*
	130	60.6	36,390	62.3	36,390	63.7	36,400
	140	57.9	32,480	59.5	32,480	61.0	32,490
	150	55.1	29,130	56.7	29,140	58.1	29,140
	160	52.2	26,230	53.8	26,230	55.1	26,240
	170	49.1	23,700	50.7	23,700	52.0	23,710
	180	45.9	21,460	47.5	21,470	48.7	21,470
	190	42.5	19,480	44.0	19,480	45.2	19,490
	200	38.9	17,710	40.4	17,710	41.5	17,720

	46	81.8	60,000*	-	-	-	-
	50	80.9	60,000*	-	-	-	-
	60	78.6	60,000*	80.3	60,000*	81.9	46,490*
	70	76.3	60,000*	78.0	60,000*	79.6	46,490*
	80	74.0	60,000*	75.7	60,000*	77.2	46,060*
	90	71.7	60,000*	73.3	58,610*	74.8	43,360*
	100	69.3	52,270	70.9	52,270	72.4	40,960*
	110	66.9	45,490	68.5	45,490	70.0	40,300*
210' (64.0 m)	120	64.4	39,950	66.0	39,960	67.5	40,220*
	130	61.9	35,860	63.5	35,870	64.9	35,870
	140	59.3	31,960	60.9	31,960	62.3	31,970
	150	56.6	28,600	58.2	28,610	59.6	28,610
	160	53.9	25,700	55.4	25,700	56.8	25,710
	170	51.1	23,170	52.6	23,170	53.8	23,180
	180	48.1	20,930	49.6	20,930	50.8	20,940
	190	45.0	18,940	46.4	18,950	47.6	18,950
	200	41.6	17,170	43.1	17,170	44.2	17,180
	210	38.1	15,580	39.5	15,580	40.5	15,590

	47	81.9	60,000*	-	-	-	-
	50	81.2	60,000*	-	-	-	-
	60	79.1	60,000*	80.7	60,000*	-	-
	70	76.9	60,000*	78.5	60,000*	80.0	46,450*
	80	74.6	60,000*	76.2	60,000*	77.7	46,450*
	90	72.4	60,000*	74.0	59,670*	75.4	44,170*
	100	70.1	51,730	71.7	51,730	73.1	41,710*
	110	67.8	44,950	69.4	44,950	70.8	40,180*
220' (67.1 m)	120	65.4	39,970	67.0	39,970	68.4	39,980
	130	63.0	35,340	64.6	35,340	65.9	35,350
	140	60.6	31,430	62.1	31,430	63.4	31,440
	150	58.1	28,080	59.6	28,080	60.9	28,080
	160	55.5	25,170	57.0	25,170	58.2	25,180
	170	52.8	22,630	54.3	22,630	55.5	22,640
	180	50.0	20,400	51.5	20,400	52.7	20,410
	190	47.1	18,410	48.5	18,410	49.7	18,420
	200	44.0	16,630	45.5	16,640	46.6	16,650
	210	40.8	15,030	42.2	15,030	43.2	15,040
	220	37.3	13,590	38.7	13,590	39.6	13,600

Boom length	Jib Radius (Feet)	5.0 Deg offset		15.0 Deg offset		25.0 Deg offset	
		Boom Angle	Rating (Pounds)	Boom Angle	Rating (Pounds)	Boom Angle	Rating (Pounds)
	48	82.0	60,000*	-	-	-	-
	50	81.6	60,000*	-	-	-	-
	60	79.5	60,000*	81.0	60,000*	-	-
	70	77.3	60,000*	78.9	60,000*	80.3	46,400*
	80	75.2	60,000*	76.7	60,000*	78.2	46,400*
	90	73.0	59,860	74.6	59,870	76.0	44,690*
	100	70.9	51,380	72.4	51,380	73.8	42,380*
	110	68.6	44,610	70.1	44,610	71.5	40,240*
230' (70.1 m)	120	66.4	39,640	67.9	39,640	69.2	39,650
	130	64.1	35,020	65.6	35,020	66.9	35,030
	140	61.7	31,100	63.2	31,110	64.5	31,110
	150	59.4	27,760	60.8	27,760	62.1	27,770
	160	56.9	24,850	58.3	24,860	59.6	24,860
	170	54.4	22,320	55.8	22,320	57.0	22,330
	180	51.7	20,080	53.2	20,080	54.3	20,090
	190	49.0	18,090	50.4	18,090	51.6	18,100
	200	46.2	16,310	47.6	16,310	48.6	16,320
	210	43.2	14,710	44.5	14,720	45.6	14,730
	220	40.0	13,270	41.3	13,280	42.3	13,280
	230	36.6	11,970	37.9	11,980	38.8	11,990

	50	81.9	60,000*	-	-	-	-
	60	79.8	60,000*	81.3	60,000*	-	-
	70	77.8	60,000*	79.3	60,000*	80.7	46,350*
	80	75.7	60,000*	77.2	60,000*	78.6	46,350*
	90	73.7	59,340	75.1	59,350	76.5	45,450*
	100	71.5	50,860	73.0	50,860	74.4	42,990*
	110	69.4	44,080	70.9	44,080	72.2	40,940*
	120	67.3	39,130	68.7	39,140	70.0	39,140
240' (73.2 m)	130	65.1	34,520	66.5	34,520	67.8	34,520
	140	62.8	30,600	64.3	30,600	65.5	30,610
	150	60.5	27,240	62.0	27,240	63.2	27,250
	160	58.2	24,350	59.6	24,350	60.8	24,350
	170	55.8	21,800	57.2	21,800	58.4	21,810
	180	53.3	19,560	54.7	19,560	55.8	19,570
	190	50.8	17,570	52.1	17,570	53.2	17,580
	200	48.1	15,800	49.4	15,800	50.5	15,810
	210	45.3	14,190	46.6	14,190	47.7	14,200
	220	42.4	12,760	43.7	12,760	44.7	12,770
	230	39.3	11,440	40.5	11,450	41.5	11,460
	240	35.9	10,250	37.2	10,260	38.0	10,270

	51	81.9	60,000*	-	-	-	-
	60	80.2	60,000*	81.6	60,000*	-	-
	70	78.2	60,000*	79.7	60,000*	81.0	46,310*
	80	76.2	60,000*	77.7	60,000*	79.0	46,310*
	90	74.2	58,800	75.7	58,810	77.0	46,090*
	100	72.2	50,310	73.6	50,310	74.9	43,690*
	110	70.1	43,530	71.6	43,530	72.9	41,630*
	120	68.1	38,610	69.5	38,610	70.7	38,620
	130	66.0	33,980	67.4	33,980	68.6	33,990
	140	63.8	30,060	65.2	30,060	66.4	30,070
250' (76.2 m)	150	61.6	26,700	63.0	26,710	64.2	26,710
	160	59.4	23,800	60.8	23,800	61.9	23,810
	170	57.1	21,250	58.5	21,260	59.6	21,260
	180	54.8	19,010	56.1	19,010	57.2	19,020
	190	52.3	17,020	53.7	17,020	54.8	17,030
	200	49.8	15,240	51.1	15,240	52.2	15,250
	210	47.2	13,640	48.5	13,640	49.5	13,650
	220	44.5	12,190	45.7	12,190	46.7	12,200
	230	41.6	10,890	42.9	10,890	43.8	10,900
	240	38.6	9,690	39.8	9,690	40.6	9,700
	250	35.3	8,600	36.5	8,600	37.3	8,610

3

WITH 92HI OFFSET TIP BOOM, #30 JIB
195,000 lb + 64,000 lb CB
360°
ANSI B 30.5
45' (13.7 m) Jib length

Boom length	Jib Radius (Feet)	5.0 Deg offset		15.0 Deg offset		25.0 Deg offset	
		Boom Angle	Rating (Pounds)	Boom Angle	Rating (Pounds)	Boom Angle	Rating (Pounds)
	53	81.8	60,000*	-	-	-	-
	60	80.5	60,000*	81.9	59,180*	-	-
	70	78.6	60,000*	80.0	57,220*	81.3	46,260*
	80	76.7	60,000*	78.1	55,010*	79.4	46,260*
	90	74.7	58,280	76.1	52,960*	77.4	46,260*
	100	72.8	49,780	74.2	49,780	75.4	44,170*
	110	70.8	42,990	72.2	42,990	73.4	42,140*
	120	68.8	38,090	70.2	38,100	71.4	38,100
	130	66.8	33,460	68.2	33,470	69.4	33,470
	140	64.7	29,540	66.1	29,550	67.3	29,550
260' (79.2 m)	150	62.6	26,180	64.0	26,180	65.2	26,190
	160	60.5	23,270	61.8	23,270	63.0	23,280
	170	58.3	20,720	59.6	20,730	60.8	20,730
	180	56.1	18,490	57.4	18,490	58.5	18,500
	190	53.8	16,500	55.1	16,500	56.1	16,510
	200	51.4	14,720	52.7	14,720	53.7	14,730
	210	48.9	13,120	50.2	13,120	51.2	13,130
	220	46.4	11,670	47.6	11,670	48.6	11,680
	230	43.7	10,350	44.9	10,360	45.9	10,360
	240	40.9	9,160	42.1	9,160	43.0	9,170
	250	37.9	8,060	39.1	8,060	39.9	8,070
	260	34.7	7,060	35.8	7,070	36.6	7,080

	54	81.9	60,000*	-	-	-	-
	60	80.8	60,000*	-	-	-	-
	70	79.0	57,650*	80.3	50,910*	81.6	44,680*
	80	77.1	54,570*	78.5	48,880*	79.7	43,530*
	90	75.2	51,710*	76.6	46,870*	77.8	42,160*
	100	73.4	49,080*	74.7	44,870*	75.9	40,770*
	110	71.5	42,460	72.8	42,460	74.0	38,430*
	120	69.5	37,580	70.8	37,580	72.0	37,030*
	130	67.6	32,940	68.9	32,940	70.1	32,950
	140	65.6	29,020	66.9	29,020	68.1	29,030
270' (82.3 m)	150	63.6	25,660	64.9	25,660	66.0	25,670
	160	61.5	22,740	62.8	22,750	63.9	22,750
	170	59.4	20,200	60.7	20,200	61.8	20,210
	180	57.3	17,950	58.6	17,950	59.6	17,960
	190	55.1	15,960	56.4	15,960	57.4	15,970
	200	52.8	14,180	54.1	14,180	55.1	14,190
	210	50.5	12,570	51.7	12,580	52.7	12,590
	220	48.1	11,130	49.3	11,130	50.3	11,140
	230	45.6	9,820	46.8	9,820	47.7	9,830
	240	43.0	8,620	44.1	8,630	45.0	8,630
	250	40.2	7,520	41.3	7,520	42.2	7,530
	260	37.3	6,520	38.4	6,520	39.2	6,530
	270	34.1	5,590	35.2	5,600	35.9	5,610

Boom length	Jib Radius (Feet)	5.0 Deg offset		15.0 Deg offset		25.0 Deg offset	
		Boom Angle	Rating (Pounds)	Boom Angle	Rating (Pounds)	Boom Angle	Rating (Pounds)
	55	82.0	52,150*	-	-	-	-
	60	81.1	50,620*	-	-	-	-
	70	79.3	47,470*	80.6	42,110*	81.9	35,710*
	80	77.5	44,590*	78.8	40,190*	80.0	34,600*
	90	75.7	42,060*	77.0	36,820*	78.2	33,560*
	100	73.9	38,230*	75.2	35,270*	76.4	32,410*
	110	72.0	36,200*	73.3	33,710*	74.5	31,240*
	120	70.2	34,350*	71.5	32,150*	72.6	29,940*
	130	68.3	32,590	69.6	30,720*	70.7	28,760*
	140	66.4	28,670	67.7	28,680	68.8	27,580*
280' (85.3 m)	150	64.5	25,300	65.7	25,310	66.8	25,310
	160	62.5	22,400	63.7	22,400	64.8	22,410
	170	60.5	19,850	61.7	19,850	62.8	19,860
	180	58.4	17,600	59.7	17,610	60.7	17,610
	190	56.3	15,620	57.5	15,620	58.6	15,630
	200	54.2	13,840	55.4	13,840	56.4	13,850
	210	52.0	12,230	53.2	12,240	54.1	12,240
	220	49.7	10,780	50.9	10,790	51.8	10,790
	230	47.3	9,470	48.5	9,470	49.4	9,480
	240	44.8	8,270	46.0	8,270	46.9	8,280
	250	42.3	7,170	43.4	7,180	44.2	7,190
	260	39.5	6,170	40.6	6,180	41.4	6,180
	270	36.6	5,240	37.7	5,250	38.5	5,260
	280	33.5	4,060*	34.6	4,360*	35.3	4,400

WITH 92HI OFFSET TIP BOOM, # 30 JIB

195,000 lb + 64,000 lb CB

360°

ANSI B 30.5

55' (16.8 m) Jib length

Boom length	Jib Radius (Feet)	5.0 Deg offset		15.0 Deg offset		25.0 Deg offset	
		Boom Angle	Rating (Pounds)	Boom Angle	Rating (Pounds)	Boom Angle	Rating (Pounds)
	38	81.9	60,000*	-	-	-	-
	40	81.3	60,000*	-	-	-	-
	50	78.3	60,000*	81.0	60,000*	-	-
	60	75.3	60,000*	78.0	56,160*	80.5	38,790*
140' (42.7 m)	70	72.3	60,000*	74.9	49,980*	77.4	38,790*
	80	69.2	59,210*	71.8	44,930*	74.2	37,500*
	90	66.0	53,090*	68.6	40,920*	71.0	34,640*
	100	62.7	47,920*	65.3	40,110*	67.6	32,290*
	110	59.3	43,890*	61.9	37,330*	64.2	30,260*
	120	55.8	40,250*	58.4	35,040*	60.6	28,400*
	130	52.2	37,680*	54.7	33,020*	56.8	26,930*
	140	48.3	35,020*	50.7	31,220*	52.8	25,650*

	39	82.0	60,000*	-	-	-	-
	40	81.7	60,000*	-	-	-	-
	50	78.9	60,000*	81.5	60,000*	-	-
	60	76.0	60,000*	78.6	57,750*	81.0	38,760*
	70	73.2	60,000*	75.7	51,650*	78.1	38,760*
	80	70.2	60,000*	72.7	46,410*	75.1	38,600*
150' (45.7 m)	90	67.2	55,290*	69.7	42,440*	72.0	35,720*
	100	64.1	50,120*	66.6	40,350*	68.9	33,270*
	110	61.0	45,660*	63.4	38,560*	65.6	31,150*
	120	57.7	42,000*	60.1	36,040*	62.3	29,330*
	130	54.3	39,080	56.7	34,050*	58.8	27,890*
	140	50.8	35,180	53.1	32,240*	55.1	26,490*
	150	47.0	31,840	49.3	30,550*	51.2	25,330*

	41	81.8	60,000*	-	-	-	-
	50	79.4	60,000*	81.9	60,000*	-	-
	60	76.7	60,000*	79.1	59,090*	81.4	38,740*
	70	74.0	60,000*	76.4	53,090*	78.6	38,740*
	80	71.2	60,000*	73.6	47,970*	75.8	38,740*
	90	68.3	57,470*	70.7	43,790*	72.9	36,670*
160' (48.8 m)	100	65.4	52,160*	67.8	40,280*	69.9	34,240*
	110	62.5	47,650*	64.8	39,570*	66.9	32,120*
	120	59.4	42,730	61.7	37,160*	63.8	30,250*
	130	56.2	38,550	58.5	35,090*	60.5	28,700*
	140	52.9	34,640	55.2	33,250*	57.1	27,310*
	150	49.5	31,300	51.7	31,310	53.6	26,150*
	160	45.8	28,410	48.0	28,420	49.8	25,120*

	42	81.9	60,000*	-	-	-	-
	50	79.9	60,000*	-	-	-	-
	60	77.3	60,000*	79.6	60,000*	81.8	38,710*
	70	74.7	60,000*	77.0	54,510*	79.2	38,710*
	80	72.0	60,000*	74.3	49,300*	76.5	38,710*
	90	69.3	59,620*	71.6	45,030*	73.7	37,580*
170' (51.8 m)	100	66.6	54,020*	68.9	41,500*	70.9	35,020*
	110	63.8	47,690	66.0	40,340*	68.0	32,900*
	120	60.9	42,170	63.1	38,200*	65.1	31,110*
	130	57.9	38,010	60.1	36,040*	62.1	29,560*
	140	54.8	34,100	57.0	34,110	58.9	28,160*
	150	51.6	30,760	53.8	30,770	55.6	26,880*
	160	48.3	27,870	50.4	27,880	52.1	25,810*
	170	44.7	25,340	46.8	25,340	48.5	24,890*

Boom length	Jib Radius (Feet)	5.0 Deg offset		15.0 Deg offset		25.0 Deg offset	
		Boom Angle	Rating (Pounds)	Boom Angle	Rating (Pounds)	Boom Angle	Rating (Pounds)
	44	81.8	60,000*	-	-	-	-
	50	80.3	60,000*	-	-	-	-
	60	77.9	60,000*	80.1	60,000*	-	-
	70	75.4	60,000*	77.6	55,610*	79.6	38,700*
	80	72.8	60,000*	75.0	50,740*	77.1	38,700*
	90	70.3	60,000*	72.4	46,410*	74.5	38,360*
180' (54.9 m)	100	67.6	54,140	69.8	42,710*	71.8	35,900*
	110	65.0	47,380	67.1	40,250*	69.1	33,790*
	120	62.3	41,860	64.4	39,200*	66.3	31,870*
	130	59.4	37,730	61.6	37,090*	63.4	30,310*
	140	56.6	33,820	58.6	33,830	60.5	28,900*
	150	53.6	30,480	55.6	30,490	57.4	27,610*
	160	50.4	27,580	52.5	27,580	54.2	26,540*
	170	47.2	25,050	49.2	25,060	50.8	25,060
	180	43.7	22,830	45.7	22,830	47.2	22,840

	45	81.9	60,000*	-	-	-	-
	50	80.7	60,000*	-	-	-	-
	60	78.4	60,000*	80.5	60,000*	-	-
	70	76.0	60,000*	78.1	56,540*	80.1	38,670*
	80	73.5	60,000*	75.7	51,980*	77.6	38,670*
	90	71.1	60,000*	73.2	47,590*	75.1	38,670*
190' (57.9 m)	100	68.6	53,610	70.7	44,070*	72.6	36,760*
	110	66.1	46,850	68.1	40,850*	70.0	34,480*
	120	63.5	41,320	65.5	40,240*	67.4	32,630*
	130	60.8	37,210	62.9	37,220	64.7	31,070*
	140	58.1	33,310	60.1	33,310	61.9	29,640*
	150	55.3	29,960	57.3	29,970	59.0	28,350*
	160	52.4	27,060	54.3	27,060	56.0	27,070
	170	49.3	24,530	51.3	24,530	52.9	24,540
	180	46.1	22,290	48.0	22,300	49.6	22,310
	190	42.7	20,320	44.6	20,320	46.1	20,330

	46	82.0	60,000*	-	-	-	-
	50	81.1	60,000*	-	-	-	-
	60	78.8	60,000*	80.9	60,000*	-	-
	70	76.5	60,000*	78.6	57,610*	80.5	38,650*
	80	74.2	60,000*	76.2	53,150*	78.1	38,650*
	90	71.9	60,000*	73.9	48,800*	75.8	38,650*
	100	69.5	53,050	71.5	45,100*	73.3	37,380*
	110	67.1	46,280	69.1	42,010*	70.9	35,230*
200' (61.0 m)	120	64.6	40,740	66.6	40,210*	68.4	33,390*
	130	62.1	36,650	64.0	36,660	65.8	31,830*
	140	59.5	32,750	61.4	32,750	63.1	30,270*
	150	56.8	29,400	58.8	29,410	60.4	28,980*
	160	54.1	26,500	56.0	26,500	57.6	26,510
	170	51.2	23,970	53.1	23,970	54.7	23,980
	180	48.3	21,730	50.1	21,730	51.6	21,740
	190	45.1	19,750	47.0	19,760	48.4	19,770
	200	41.8	17,980	43.6	17,980	45.0	17,990

3

WITH 92HI OFFSET TIP BOOM, #30 JIB

195,000 lb + 64,000 lb CB

360°

ANSI B 30.5

55' (16.8 m) Jib length

Boom length	Jib Radius (Feet)	5.0 Deg offset		15.0 Deg offset		25.0 Deg offset	
		Boom Angle	Rating (Pounds)	Boom Angle	Rating (Pounds)	Boom Angle	Rating (Pounds)
	48	81.9	60,000*	-	-	-	-
	50	81.4	60,000*	-	-	-	-
	60	79.2	60,000*	81.2	60,000*	-	-
	70	77.0	60,000*	79.0	58,560*	80.9	38,620*
	80	74.8	60,000*	76.8	54,070*	78.6	38,620*
	90	72.6	60,000*	74.5	49,850*	76.3	38,620*
	100	70.3	52,510	72.2	46,150*	74.0	38,120*
	110	68.0	45,740	69.9	43,040*	71.6	36,060*
210' (64.0 m)	120	65.6	40,200	67.5	40,200	69.3	34,160*
	130	63.2	36,140	65.1	36,140	66.8	32,460*
	140	60.8	32,220	62.6	32,220	64.3	31,030*
	150	58.2	28,880	60.1	28,880	61.7	28,890
	160	55.7	25,970	57.5	25,980	59.1	25,980
	170	53.0	23,440	54.8	23,440	56.3	23,450
	180	50.2	21,200	52.0	21,200	53.5	21,210
	190	47.3	19,210	49.1	19,210	50.5	19,220
	200	44.2	17,440	46.0	17,450	47.3	17,460
	210	41.0	15,840	42.7	15,840	44.0	15,850

	49	81.9	60,000*	-	-	-	-
	50	81.7	60,000*	-	-	-	-
	60	79.6	60,000*	81.5	60,000*	-	-
	70	77.5	60,000*	79.4	59,320*	81.2	38,600*
	80	75.4	60,000*	77.3	54,890*	79.0	38,600*
	90	73.2	60,000*	75.1	51,040*	76.8	38,600*
	100	71.0	51,970	72.9	47,230*	74.6	38,600*
	110	68.8	45,190	70.7	44,090*	72.4	36,670*
220' (67.1 m)	120	66.6	40,230	68.4	40,230	70.1	34,780*
	130	64.3	35,600	66.1	35,610	67.7	33,080*
	140	61.9	31,690	63.7	31,700	65.4	31,660*
	150	59.5	28,340	61.3	28,340	62.9	28,350
	160	57.1	25,440	58.9	25,450	60.4	25,450
	170	54.5	22,900	56.3	22,900	57.8	22,910
	180	51.9	20,660	53.7	20,660	55.1	20,670
	190	49.2	18,680	50.9	18,680	52.3	18,690
	200	46.4	16,900	48.0	16,900	49.4	16,910
	210	43.4	15,300	45.0	15,310	46.3	15,320
	220	40.2	13,860	41.8	13,870	43.0	13,880

	51	81.8	60,000*	-	-	-	-
	60	80.0	60,000*	81.8	60,000*	-	-
	70	78.0	60,000*	79.8	60,000*	81.5	38,580*
	80	75.9	60,000*	77.7	55,800*	79.4	38,580*
	90	73.8	60,000*	75.6	51,930*	77.3	38,580*
	100	71.7	51,620	73.5	48,370*	75.2	38,580*
	110	69.6	44,840	71.4	44,840	73.0	37,420*
	120	67.4	39,900	69.2	39,910	70.8	35,390*
230' (70.1 m)	130	65.2	35,280	67.0	35,280	68.6	33,700*
	140	63.0	31,370	64.8	31,370	66.3	31,380
	150	60.7	28,020	62.5	28,020	64.0	28,030
	160	58.4	25,120	60.1	25,120	61.6	25,130
	170	56.0	22,570	57.7	22,570	59.1	22,580
	180	53.5	20,340	55.2	20,340	56.6	20,350
	190	50.9	18,350	52.6	18,350	54.0	18,360
	200	48.3	16,580	49.9	16,580	51.3	16,590
	210	45.5	14,980	47.1	14,980	48.4	14,990
	220	42.5	13,540	44.1	13,540	45.4	13,550
	230	39.4	12,220	41.0	12,230	42.2	12,240

Boom length	Jib Radius (Feet)	5.0 Deg offset		15.0 Deg offset		25.0 Deg offset	
		Boom Angle	Rating (Pounds)	Boom Angle	Rating (Pounds)	Boom Angle	Rating (Pounds)
	52	81.9	60,000*	-	-	-	-
	60	80.3	60,000*	-	-	-	-
	70	78.4	60,000*	80.1	60,000*	81.8	38,550*
	80	76.4	60,000*	78.2	56,670*	79.8	38,550*
	90	74.4	59,580	76.1	52,800*	77.8	38,550*
	100	72.4	51,090	74.1	49,270*	75.7	38,550*
	110	70.3	44,310	72.0	44,310	73.6	38,010*
	120	68.2	39,400*	70.0	39,400*	71.5	36,000*
240' (73.2 m)	130	66.1	34,770	67.8	34,770	69.4	34,310*
	140	64.0	30,850	65.7	30,850	67.2	30,860
	150	61.8	27,500	63.5	27,510	65.0	27,510
	160	59.6	24,600	61.2	24,600	62.7	24,610
	170	57.3	22,060	58.9	22,070	60.4	22,070
	180	54.9	19,820	56.6	19,820	58.0	19,830
	190	52.5	17,830	54.1	17,830	55.5	17,840
	200	50.0	16,050	51.6	16,050	52.9	16,060
	210	47.4	14,460	49.0	14,460	50.2	14,470
	220	44.6	13,010	46.2	13,020	47.4	13,020
	230	41.8	11,700	43.3	11,700	44.5	11,710
	240	38.7	10,510	40.2	10,510	41.3	10,520

	53	82.0	60,000*	-	-	-	-
	60	80.7	60,000*	-	-	-	-
	70	78.8	60,000*	80.5	59,630*	-	-
	80	76.8	60,000*	78.6	57,290*	80.2	38,530*
	90	74.9	59,030	76.6	53,640*	78.2	38,530*
	100	73.0	50,540	74.6	50,270*	76.2	38,530*
	110	71.0	43,760	72.7	43,760	74.2	38,530*
	120	69.0	38,860	70.7	38,870	72.2	36,600*
	130	67.0	34,230	68.6	34,240	70.1	34,240
	140	64.9	30,320	66.5	30,320	68.0	30,330
250' (76.2 m)	150	62.8	26,960	64.4	26,960	65.9	26,970
	160	60.7	24,050	62.3	24,050	63.7	24,060
	170	58.5	21,510	60.1	21,520	61.5	21,530
	180	56.2	19,270	57.8	19,270	59.2	19,280
	190	53.9	17,280	55.5	17,280	56.9	17,290
	200	51.6	15,500	53.1	15,500	54.4	15,510
	210	49.1	13,900	50.6	13,900	51.9	13,910
	220	46.5	12,460	48.1	12,460	49.3	12,470
	230	43.9	11,140	45.4	11,150	46.5	11,160
	240	41.0	9,950	42.5	9,950	43.6	9,960
	250	38.0	8,860	39.5	8,860	40.5	8,870

WITH 92HI OFFSET TIP BOOM, #30 JIB

195,000 lb + 64,000 lb CB

360°

ANSI B 30.5

55' (16.8 m) Jib length

Boom length	Jib Radius (Feet)	5.0 Deg offset Boom Angle	5.0 Deg offset Rating (Pounds)	15.0 Deg offset Boom Angle	15.0 Deg offset Rating (Pounds)	25.0 Deg offset Boom Angle	25.0 Deg offset Rating (Pounds)
	55	81.9	60,000*	-	-	-	-
	60	81.0	60,000*	-	-	-	-
	70	79.1	60,000*	80.8	53,180*	-	-
	80	77.3	58,460*	78.9	51,530*	80.5	38,510*
	90	75.4	55,580*	77.0	49,570*	78.6	38,510*
	100	73.5	50,010	75.2	47,680*	76.7	38,510*
	110	71.6	43,220	73.2	43,220	74.7	38,510*
	120	69.7	38,350	71.3	38,350	72.8	37,180*
	130	67.7	33,720	69.3	33,720	70.8	33,730
	140	65.7	29,800	67.4	29,800	68.8	29,810
260' (79.2 m)	150	63.7	26,440	65.3	26,440	66.7	26,450
	160	61.7	23,530	63.3	23,540	64.7	23,540
	170	59.6	20,990	61.2	20,990	62.5	21,000
	180	57.4	18,740	59.0	18,750	60.3	18,750
	190	55.3	16,750	56.8	16,750	58.1	16,760
	200	53.0	14,970	54.5	14,970	55.8	14,980
	210	50.7	13,360	52.2	13,370	53.4	13,380
	220	48.3	11,930	49.7	11,930	51.0	11,940
	230	45.7	10,610	47.2	10,610	48.4	10,620
	240	43.1	9,410	44.6	9,420	45.7	9,430
	250	40.3	8,320	41.8	8,320	42.8	8,330
	260	37.4	7,320	38.8	7,330	39.8	7,340

	56	81.9	59,530*	-	-	-	-
	60	81.2	58,160*	-	-	-	-
	70	79.5	54,860*	81.1	47,450*	-	-
	80	77.7	52,000*	79.3	45,640*	80.8	38,490*
	90	75.9	49,220*	77.5	44,000*	78.9	37,670*
	100	74.0	46,730*	75.6	42,190*	77.1	36,690*
	110	72.2	42,690	73.8	40,390*	75.2	35,770*
	120	70.3	37,830	71.9	37,780*	73.3	34,650*
	130	68.5	33,190	70.0	33,200	71.4	33,200
	140	66.5	29,270	68.1	29,280	69.5	29,280
270' (82.3 m)	150	64.6	25,910	66.1	25,920	67.5	25,930
	160	62.6	23,010	64.2	23,010	65.5	23,020
	170	60.6	20,460	62.1	20,460	63.5	20,470
	180	58.6	18,210	60.1	18,220	61.4	18,230
	190	56.5	16,220	58.0	16,220	59.3	16,230
	200	54.3	14,440	55.8	14,440	57.1	14,450
	210	52.1	12,830	53.6	12,840	54.8	12,850
	220	49.8	11,380	51.3	11,390	52.5	11,400
	230	47.5	10,080	48.9	10,080	50.0	10,090
	240	45.0	8,880	46.4	8,880	47.5	8,890
	250	42.4	7,780	43.8	7,790	44.9	7,800
	260	39.7	6,770	41.0	6,780	42.1	6,790
	270	36.8	5,850	38.1	5,860	39.1	5,870

Boom length	Jib Radius (Feet)	5.0 Deg offset Boom Angle	5.0 Deg offset Rating (Pounds)	15.0 Deg offset Boom Angle	15.0 Deg offset Rating (Pounds)	25.0 Deg offset Boom Angle	25.0 Deg offset Rating (Pounds)
	58	81.8	48,830*	-	-	-	-
	60	81.5	48,350*	-	-	-	-
	70	79.8	45,380*	81.3	37,580*	-	-
	80	78.0	42,620*	79.6	36,270*	81.1	31,890*
	90	76.3	40,170*	77.8	34,690*	79.3	31,030*
	100	74.5	36,650*	76.1	33,260*	77.5	30,030*
	110	72.7	34,750*	74.3	31,860*	75.7	29,010*
	120	70.9	32,910*	72.5	30,440*	73.9	27,960*
	130	69.1	31,220*	70.6	29,150*	72.0	26,980*
	140	67.3	28,920	68.8	27,860*	70.2	25,920*
280' (85.3 m)	150	65.4	25,560	66.9	25,560	68.3	24,860*
	160	63.5	22,650	65.0	22,650	66.3	22,660
	170	61.6	20,100	63.1	20,110	64.4	20,110
	180	59.6	17,860	61.1	17,860	62.4	17,870
	190	57.6	15,860	59.1	15,870	60.3	15,870
	200	55.5	14,090	57.0	14,090	58.2	14,100
	210	53.4	12,480	54.9	12,490	56.1	12,500
	220	51.3	11,030	52.7	11,040	53.9	11,050
	230	49.0	9,710	50.4	9,720	51.6	9,730
	240	46.7	8,520	48.1	8,520	49.2	8,530
	250	44.3	7,420	45.6	7,420	46.7	7,430
	260	41.7	6,410	43.1	6,420	44.1	6,430
	270	39.1	5,490	40.4	5,500	41.3	5,510
	280	36.2	4,480*	37.5	4,640	38.4	4,650

3

WITH 92HI OFFSET TIP BOOM, #30 JIB

195,000 lb + 64,000 lb CB

360°

ANSI B 30.5

65' (19.8 m) Jib length

Boom length	Jib Radius (Feet)	5.0 Deg offset		15.0 Deg offset		25.0 Deg offset	
		Boom Angle	Rating (Pounds)	Boom Angle	Rating (Pounds)	Boom Angle	Rating (Pounds)
	45	81.8	55,300*	-	-	-	-
	50	80.5	54,350*	-	-	-	-
	60	78.1	52,480*	80.7	47,400*	-	-
	70	75.6	50,780*	78.2	46,300*	80.7	32,810*
	80	73.0	49,330*	75.6	42,120*	78.1	32,810*
	90	70.5	47,820*	73.1	39,560*	75.5	31,490*
170' (51.8 m)	100	67.9	46,420*	70.4	38,510*	72.8	29,380*
	110	65.2	43,830*	67.7	35,980*	70.1	27,670*
	120	62.5	39,520*	65.0	33,670*	67.3	26,050*
	130	59.7	37,870*	62.2	31,740*	64.4	24,680*
	140	56.8	34,300	59.3	29,790*	61.4	23,550*
	150	53.8	30,960	56.2	28,030*	58.4	22,430*
	160	50.6	28,060	53.1	26,540*	55.1	21,500*
	170	47.4	25,530	49.8	25,170*	51.8	20,660*

	46	81.9	54,770*	-	-	-	-
	50	80.9	54,180*	-	-	-	-
	60	78.6	52,460*	81.1	47,220*	-	-
	70	76.2	51,020*	78.7	46,270*	81.1	32,780*
	80	73.7	49,390*	76.3	43,270*	78.6	32,780*
	90	71.3	47,960*	73.8	39,680*	76.1	32,150*
180' (54.9 m)	100	68.8	46,770*	71.3	38,840*	73.6	30,040*
	110	66.3	45,340*	68.7	36,800*	71.0	28,260*
	120	63.7	41,540*	66.1	34,560*	68.3	26,670*
	130	61.0	37,910	63.4	32,640*	65.6	25,390*
	140	58.3	34,010	60.7	30,820*	62.8	24,150*
	150	55.5	30,660	57.9	29,000*	59.9	23,020*
	160	52.6	27,770	54.9	27,370*	56.9	22,090*
	170	49.5	25,240	51.8	25,240	53.8	21,230*
	180	46.3	23,000	48.6	23,010	50.5	20,470*

	47	82.0	54,660*	-	-	-	-
	50	81.3	54,120*	-	-	-	-
	60	79.0	52,590*	81.4	47,250*	-	-
	70	76.7	51,110*	79.1	46,110*	81.4	32,760*
	80	74.4	49,680*	76.8	44,270*	79.1	32,760*
	90	72.1	48,310*	74.5	40,450*	76.7	32,760*
190' (57.9 m)	100	69.7	46,910*	72.1	39,020*	74.3	30,730*
	110	67.3	45,730*	69.6	37,710*	71.8	28,940*
	120	64.8	41,470	67.1	35,320*	69.3	27,290*
	130	62.3	37,390	64.6	33,400*	66.7	25,900*
	140	59.7	33,490	62.0	31,570*	64.1	24,640*
	150	57.0	30,140	59.3	29,910*	61.3	23,610*
	160	54.3	27,240	56.5	27,240	58.5	22,580*
	170	51.4	24,710	53.7	24,710	55.6	21,710*
	180	48.5	22,480	50.7	22,480	52.5	20,960*
	190	45.3	20,490	47.5	20,500	49.3	20,300*

Boom length	Jib Radius (Feet)	5.0 Deg offset		15.0 Deg offset		25.0 Deg offset	
		Boom Angle	Rating (Pounds)	Boom Angle	Rating (Pounds)	Boom Angle	Rating (Pounds)
	49	81.8	54,500*	-	-	-	-
	50	81.6	54,280*	-	-	-	-
	60	79.4	52,920*	81.8	47,270*	-	-
	70	77.2	51,380*	79.6	46,320*	81.8	32,730*
	80	75.0	49,940*	77.3	45,200*	79.5	32,730*
	90	72.8	48,680*	75.1	41,450*	77.2	32,730*
	100	70.5	47,450*	72.8	39,160*	74.9	31,280*
	110	68.2	46,240*	70.4	38,370*	72.5	29,420*
200' (61.0 m)	120	65.8	40,900	68.1	36,220*	70.1	27,910*
	130	63.4	36,840	65.7	34,160*	67.7	26,510*
	140	60.9	32,930	63.2	32,330*	65.2	25,240*
	150	58.4	29,590	60.6	29,590	62.6	24,110*
	160	55.8	26,690	58.0	26,700	59.9	23,170*
	170	53.2	24,150	55.3	24,150	57.2	22,290*
	180	50.4	21,920	52.5	21,920	54.3	21,450*
	190	47.5	19,930	49.6	19,930	51.3	19,940
	200	44.4	18,160	46.5	18,170	48.2	18,180

	50	81.9	54,220*	-	-	-	-
	60	79.8	52,820*	-	-	-	-
	70	77.7	51,470*	79.9	46,350*	-	-
	80	75.6	50,010*	77.8	45,420*	79.9	32,720*
	90	73.4	48,880*	75.6	42,310*	77.7	32,720*
	100	71.2	47,530*	73.4	39,310*	75.5	31,790*
	110	69.0	45,900	71.2	38,690*	73.2	30,060*
	120	66.7	40,360	68.9	36,970*	70.9	28,410*
210' (64.0 m)	130	64.4	36,320	66.6	34,920*	68.6	27,040*
	140	62.1	32,400	64.3	32,410	66.2	25,740*
	150	59.7	29,060	61.8	29,060	63.7	24,700*
	160	57.2	26,150	59.4	26,160	61.2	23,670*
	170	54.7	23,620	56.8	23,620	58.6	22,780*
	180	52.1	21,390	54.2	21,390	55.9	21,400
	190	49.4	19,400	51.4	19,400	53.1	19,410
	200	46.5	17,620	48.5	17,630	50.2	17,630
	210	43.5	16,020	45.5	16,030	47.1	16,040

	51	82.0	54,030*	-	-	-	-
	60	80.2	52,740*	-	-	-	-
	70	78.1	51,550*	80.3	46,300*	-	-
	80	76.1	50,270*	78.2	45,430*	80.3	32,690*
	90	74.0	48,900*	76.1	43,240*	78.2	32,690*
	100	71.9	47,770*	74.0	40,010*	76.0	32,380*
	110	69.8	45,350	71.9	38,660*	73.9	30,560*
	120	67.6	39,800	69.7	37,730*	71.7	28,980*
220' (67.1 m)	130	65.4	35,790	67.5	35,690*	69.4	27,560*
	140	63.2	31,880	65.3	31,880	67.1	26,260*
	150	60.9	28,530	63.0	28,530	64.8	25,200*
	160	58.5	25,630	60.6	25,630	62.4	24,160*
	170	56.1	23,080	58.2	23,090	59.9	23,090
	180	53.7	20,850	55.7	20,850	57.4	20,860
	190	51.1	18,860	53.1	18,860	54.8	18,870
	200	48.4	17,090	50.4	17,090	52.0	17,100
	210	45.6	15,490	47.6	15,500	49.2	15,510
	220	42.7	14,050	44.6	14,050	46.1	14,060

WITH 92HI OFFSET TIP BOOM, #30 JIB

195,000 lb + 64,000 lb CB

360°

ANSI B 30.5

65' (19.8 m) Jib length

Boom length	Jib Radius (Feet)	5.0 Deg offset Boom Angle	5.0 Deg offset Rating (Pounds)	15.0 Deg offset Boom Angle	15.0 Deg offset Rating (Pounds)	25.0 Deg offset Boom Angle	25.0 Deg offset Rating (Pounds)
	53	81.9	53,220*	-	-	-	-
	60	80.5	52,420*	-	-	-	-
	70	78.5	51,160*	80.6	45,890*	-	-
	80	76.6	49,870*	78.6	45,000*	80.6	32,670*
	90	74.6	48,810*	76.6	44,010*	78.6	32,670*
	100	72.5	47,620*	74.6	40,750*	76.5	32,670*
	110	70.5	44,990	72.5	38,640*	74.4	31,050*
	120	68.4	40,080	70.5	38,020*	72.3	29,490*
230' (70.1 m)	130	66.3	35,450	68.3	35,450	70.2	28,070*
	140	64.1	31,540	66.2	31,550	68.0	26,780*
	150	62.0	28,190	64.0	28,200	65.8	25,590*
	160	59.7	25,290	61.7	25,290	63.5	24,560*
	170	57.4	22,750	59.4	22,760	61.1	22,770
	180	55.1	20,510	57.0	20,510	58.7	20,520
	190	52.7	18,530	54.6	18,530	56.2	18,540
	200	50.1	16,750	52.1	16,750	53.7	16,760
	210	47.5	15,160	49.4	15,160	51.0	15,170
	220	44.8	13,710	46.7	13,720	48.2	13,730
	230	41.9	12,410	43.8	12,410	45.2	12,420

	54	82.0	52,810*	-	-	-	-
	60	80.8	52,150*	-	-	-	-
	70	78.9	51,040*	81.0	45,690*	-	-
	80	77.0	49,920*	79.0	44,910*	80.9	32,640*
	90	75.1	48,840*	77.1	44,220*	79.0	32,640*
	100	73.1	47,670*	75.1	41,540*	77.0	32,640*
	110	71.1	44,460	73.1	38,770*	75.0	31,550*
	120	69.1	39,570	71.1	38,150*	72.9	29,990*
240' (73.2 m)	130	67.1	34,940	69.1	34,950	70.9	28,460*
	140	65.1	31,040	67.0	31,040	68.8	27,290*
	150	63.0	27,680	64.9	27,680	66.6	26,110*
	160	60.8	24,770	62.8	24,770	64.5	24,780
	170	58.6	22,230	60.6	22,240	62.2	22,250
	180	56.4	19,990	58.3	19,990	59.9	20,000
	190	54.1	18,010	56.0	18,010	57.6	18,020
	200	51.7	16,230	53.6	16,230	55.1	16,240
	210	49.3	14,630	51.1	14,630	52.6	14,640
	220	46.7	13,190	48.5	13,190	50.0	13,200
	230	44.0	11,870	45.8	11,880	47.2	11,890
	240	41.2	10,680	43.0	10,680	44.3	10,700

	56	81.8	52,570*	-	-	-	-
	60	81.1	52,180*	-	-	-	-
	70	79.3	51,090*	81.2	45,560*	-	-
	80	77.4	49,940*	79.4	44,910*	81.2	32,620*
	90	75.6	48,860*	77.5	44,210*	79.3	32,620*
	100	73.7	47,980*	75.6	39,450*	77.4	32,620*
	110	71.8	43,910	73.7	38,880*	75.5	31,920*
	120	69.8	39,040	71.8	38,280*	73.5	30,370*
	130	67.9	34,410	69.8	34,410	71.5	28,960*
	140	65.9	30,490	67.8	30,490	69.5	27,680*
250' (76.2 m)	150	63.9	27,130	65.8	27,130	67.5	26,520*
	160	61.8	24,230	63.7	24,240	65.4	24,250
	170	59.7	21,690	61.6	21,690	63.2	21,700
	180	57.6	19,440	59.5	19,450	61.1	19,450
	190	55.4	17,460	57.2	17,460	58.8	17,470
	200	53.1	15,680	55.0	15,680	56.5	15,690
	210	50.8	14,070	52.6	14,080	54.1	14,090
	220	48.4	12,630	50.2	12,630	51.6	12,640
	230	45.9	11,320	47.6	11,320	49.1	11,330
	240	43.3	10,120	45.0	10,130	46.3	10,140
	250	40.5	9,030	42.2	9,040	43.5	9,050

Boom length	Jib Radius (Feet)	5.0 Deg offset Boom Angle	5.0 Deg offset Rating (Pounds)	15.0 Deg offset Boom Angle	15.0 Deg offset Rating (Pounds)	25.0 Deg offset Boom Angle	25.0 Deg offset Rating (Pounds)
	57	81.9	52,170*	-	-	-	-
	60	81.4	51,920*	-	-	-	-
	70	79.6	50,830*	81.5	45,210*	-	-
	80	77.8	49,740*	79.7	44,540*	81.5	32,600*
	90	76.0	48,810*	77.9	43,950*	79.7	32,600*
	100	74.2	47,780*	76.1	43,140*	77.8	32,600*
	110	72.3	43,370	74.2	38,720*	76.0	32,420*
	120	70.5	38,520	72.4	38,250*	74.1	30,850*
260' (79.2 m)	130	68.6	33,890	70.5	33,900	72.2	29,420*
	140	66.7	29,970	68.5	29,980	70.2	28,120*
	150	64.8	26,610	66.6	26,620	68.2	26,630
	160	62.8	23,710	64.6	23,710	66.2	23,720
	170	60.8	21,160	62.6	21,160	64.2	21,170
	180	58.7	18,920	60.5	18,930	62.1	18,940
	190	56.6	16,930	58.4	16,930	59.9	16,940
	200	54.5	15,150	56.2	15,150	57.7	15,160
	210	52.3	13,540	54.0	13,550	55.5	13,560
	220	50.0	12,090	51.7	12,100	53.1	12,110
	230	47.6	10,790	49.3	10,790	50.7	10,800
	240	45.1	9,590	46.8	9,590	48.2	9,600
	250	42.6	8,490	44.2	8,500	45.5	8,510
	260	39.8	7,490	41.5	7,500	42.7	7,510

	58	82.0	51,540*	-	-	-	-
	60	81.6	51,350*	-	-	-	-
	70	79.9	50,370*	81.8	44,310*	-	-
	80	78.2	49,430*	80.0	42,850*	81.8	32,570*
	90	76.4	47,160*	78.3	41,210*	80.0	32,570*
	100	74.7	44,580*	76.5	38,370*	78.2	32,570*
	110	72.9	42,330*	74.7	36,970*	76.4	32,570*
	120	71.1	38,010	72.9	35,590*	74.6	31,220*
270' (82.3 m)	130	69.3	33,380	71.1	33,380	72.7	29,800*
	140	67.4	29,450	69.2	29,450	70.9	28,510*
	150	65.6	26,090	67.3	26,090	69.0	26,100
	160	63.7	23,180	65.4	23,180	67.0	23,190
	170	61.7	20,630	63.5	20,640	65.1	20,650
	180	59.8	18,390	61.5	18,390	63.0	18,400
	190	57.7	16,390	59.5	16,400	61.0	16,400
	200	55.7	14,620	57.4	14,620	58.9	14,630
	210	53.6	13,010	55.3	13,020	56.7	13,030
	220	51.4	11,560	53.1	11,570	54.5	11,580
	230	49.2	10,250	50.8	10,260	52.2	10,270
	240	46.8	9,060	48.5	9,060	49.8	9,070
	250	44.4	7,960	46.0	7,960	47.3	7,980
	260	41.9	6,940	43.5	6,950	44.7	6,960
	270	39.2	6,020	40.8	6,030	41.9	6,040

3

WITH 92HI OFFSET TIP BOOM, #30 JIB

195,000 lb + 64,000 lb CB

360°

ANSI B 30.5

65' (19.8 m) Jib length

Boom length	Jib Radius (Feet)	5.0 Deg offset		15.0 Deg offset		25.0 Deg offset	
		Boom Angle	Rating (Pounds)	Boom Angle	Rating (Pounds)	Boom Angle	Rating (Pounds)
	60	81.9	46,040*	-	-	-	-
	70	80.2	43,270*	-	-	-	-
	80	78.5	40,730*	80.3	34,030*	-	-
	90	76.8	36,990*	78.6	32,710*	80.3	28,640*
	100	75.1	35,070*	76.9	31,430*	78.6	27,810*
	110	73.4	33,240*	75.2	30,130*	76.8	26,940*
	120	71.7	31,570*	73.4	28,820*	75.0	26,090*
	130	69.9	29,890*	71.7	27,510*	73.3	25,130*
	140	68.1	28,480*	69.9	26,310*	71.4	24,300*
	150	66.3	25,730	68.0	25,240*	69.6	23,370*
280' (85.3 m)	160	64.5	22,810	66.2	22,820	67.8	22,430*
	170	62.6	20,280	64.3	20,280	65.9	20,290
	180	60.7	18,030	62.4	18,030	63.9	18,040
	190	58.8	16,030	60.5	16,040	62.0	16,050
	200	56.8	14,250	58.5	14,250	60.0	14,260
	210	54.8	12,660	56.5	12,660	57.9	12,670
	220	52.7	11,200	54.4	11,210	55.8	11,220
	230	50.6	9,890	52.2	9,900	53.6	9,910
	240	48.4	8,690	50.0	8,700	51.3	8,710
	250	46.1	7,600	47.7	7,600	49.0	7,610
	260	43.7	6,590	45.3	6,600	46.5	6,610
	270	41.2	5,670	42.8	5,670	43.9	5,680
	280	38.6	4,740*	40.1	4,810	41.2	4,820

75' (22.9 m) Jib length

Boom length	Jib Radius (Feet)	5.0 Deg offset		15.0 Deg offset		25.0 Deg offset	
		Boom Angle	Rating (Pounds)	Boom Angle	Rating (Pounds)	Boom Angle	Rating (Pounds)
	50	81.8	42,120*	-	-	-	-
	60	79.6	36,150*	-	-	-	-
	70	77.4	35,050*	80.1	31,710*	-	-
	80	75.2	33,980*	77.9	30,930*	80.4	28,010*
	90	72.9	32,970*	75.6	30,010*	78.1	27,230*
	100	70.7	32,130*	73.3	29,180*	75.8	26,310*
190' (57.9 m)	110	68.3	31,330*	71.0	28,270*	73.4	24,710*
	120	66.0	30,210*	68.6	27,480*	71.0	23,350*
	130	63.6	29,320*	66.2	26,840*	68.6	22,140*
	140	61.1	28,390*	63.7	26,200*	66.1	21,120*
	150	58.6	27,630*	61.2	25,560*	63.5	20,100*
	160	56.0	26,880*	58.6	24,330*	60.8	19,250*
	170	53.3	24,870	55.9	23,080*	58.0	18,460*
	180	50.6	22,630	53.0	21,970*	55.2	17,780*
	190	47.6	20,650	50.1	20,660	52.2	17,170*

	51	81.9	42,160*	-	-	-	-
	60	80.0	36,290*	-	-	-	-
	70	77.9	35,250*	80.5	31,790*	-	-
	80	75.7	34,200*	78.3	31,060*	80.8	28,120*
	90	73.6	33,250*	76.2	30,210*	78.6	27,440*
	100	71.4	32,450*	74.0	29,350*	76.4	26,780*
200' (61.0 m)	110	69.2	31,600*	71.7	28,580*	74.1	25,170*
	120	66.9	30,710*	69.5	27,760*	71.8	23,840*
	130	64.6	29,660*	67.1	27,040*	69.4	22,620*
	140	62.3	28,780*	64.8	26,390*	67.0	21,530*
	150	59.9	28,020*	62.4	25,750*	64.6	20,590*
	160	57.4	26,840	59.9	25,030*	62.1	19,660*
	170	54.9	24,310	57.3	23,800*	59.5	18,900*
	180	52.3	22,080	54.7	22,080	56.8	18,220*
	190	49.5	20,090	51.9	20,090	54.0	17,600*
	200	46.7	18,320	49.1	18,330	51.0	17,020*

Boom length	Jib Radius (Feet)	5.0 Deg offset		15.0 Deg offset		25.0 Deg offset	
		Boom Angle	Rating (Pounds)	Boom Angle	Rating (Pounds)	Boom Angle	Rating (Pounds)
	52	82.0	42,170*	-	-	-	-
	60	80.3	36,440*	-	-	-	-
	70	78.3	35,310*	80.8	31,800*	-	-
	80	76.2	34,380*	78.8	31,060*	81.1	28,240*
	90	74.2	33,470*	76.7	30,480*	79.0	27,550*
	100	72.1	32,540*	74.5	29,540*	76.9	26,900*
	110	69.9	31,720*	72.4	28,720*	74.7	25,680*
	120	67.8	30,940*	70.2	27,960*	72.5	24,230*
210' (64.0 m)	130	65.6	30,040*	68.0	27,330*	70.2	23,070*
	140	63.3	29,160*	65.8	26,690*	67.9	21,940*
	150	61.1	28,340*	63.5	26,050*	65.6	21,000*
	160	58.7	26,320	61.1	25,520*	63.2	20,150*
	170	56.3	23,780	58.7	23,790	60.7	19,290*
	180	53.8	21,540	56.2	21,540	58.2	18,580*
	190	51.3	19,560	53.6	19,560	55.6	17,970*
	200	48.6	17,780	50.9	17,780	52.8	17,380*
	210	45.8	16,180	48.1	16,190	49.9	16,200

WITH 92HI OFFSET TIP BOOM, # 30 JIB

195,000 lb + 64,000 lb CB

360°

ANSI B 30.5

75' (22.9 m) Jib length

Boom length	Jib Radius (Feet)	5.0 Deg offset		15.0 Deg offset		25.0 Deg offset	
		Boom Angle	Rating (Pounds)	Boom Angle	Rating (Pounds)	Boom Angle	Rating (Pounds)
	54	81.9	41,850*	-	-	-	-
	60	80.7	36,400*	-	-	-	-
	70	78.7	36,400*	81.1	31,850*	-	-
	80	76.7	34,550*	79.1	31,120*	81.4	28,230*
	90	74.7	33,680*	77.1	30,500*	79.4	27,650*
	100	72.7	32,760*	75.1	29,710*	77.3	27,010*
	110	70.6	31,950*	73.0	28,940*	75.2	26,100*
	120	68.6	31,180*	70.9	28,170*	73.1	24,730*
220' (67.1 m)	130	66.5	30,420*	68.8	27,530*	71.0	23,480*
	140	64.3	29,500*	66.7	26,880*	68.8	22,350*
	150	62.1	28,680*	64.5	26,240*	66.5	21,410*
	160	59.9	25,780*	62.2	25,710*	64.3	20,550*
	170	57.6	23,240*	59.9	23,250*	61.9	19,700*
	180	55.3	21,010*	57.5	21,010*	59.5	19,020*
	190	52.8	19,020*	55.1	19,020*	57.0	18,330*
	200	50.3	17,250*	52.5	17,250*	54.4	17,260*
	210	47.7	15,650*	49.9	15,650*	51.7	15,660*
	220	45.0	14,200*	47.1	14,210*	48.9	14,220*

	55	81.9	41,460*	-	-	-	-
	60	81.0	36,350*	-	-	-	-
	70	79.1	36,350*	81.4	31,700*	-	-
	80	77.2	34,540*	79.5	31,100*	81.7	28,290*
	90	75.2	33,730*	77.6	30,480*	79.8	27,710*
	100	73.3	32,830*	75.6	29,860*	77.8	27,090*
	110	71.3	32,060*	73.6	29,200*	75.8	26,500*
	120	69.3	31,290*	71.6	28,440*	73.7	25,120*
230' (70.1 m)	130	67.3	30,640*	69.6	27,690*	71.7	23,880*
	140	65.2	29,880*	67.5	27,060*	69.6	22,750*
	150	63.1	28,350*	65.4	26,540*	67.4	21,810*
	160	61.0	25,440*	63.2	25,440*	65.2	20,870*
	170	58.8	22,900*	61.0	22,910*	63.0	20,110*
	180	56.6	20,660*	58.8	20,670*	60.7	19,330*
	190	54.3	18,680*	56.4	18,680*	58.3	18,690*
	200	51.9	16,910*	54.0	16,910*	55.9	16,920*
	210	49.4	15,310*	51.6	15,310*	53.3	15,320*
	220	46.9	13,860*	49.0	13,860*	50.7	13,870*
	230	44.2	12,550*	46.3	12,560*	47.9	12,570*

	57	81.8	36,690*	-	-	-	-
	60	81.3	36,690*	-	-	-	-
	70	79.4	35,470*	81.7	31,730*	-	-
	80	77.6	34,600*	79.8	31,110*	82.0	28,270*
	90	75.7	33,790*	78.0	30,520*	80.1	27,820*
	100	73.8	33,040*	76.1	29,890*	78.2	27,220*
	110	71.9	32,170*	74.2	29,300*	76.2	26,590*
	120	70.0	31,520*	72.2	28,660*	74.3	25,510*
240' (73.2 m)	130	68.0	30,870*	70.3	27,900*	72.3	24,270*
	140	66.1	30,230*	68.3	27,260*	70.3	23,140*
	150	64.0	27,830*	66.2	26,730*	68.2	22,120*
	160	62.0	24,920*	64.2	24,930*	66.1	21,280*
	170	59.9	22,390*	62.1	22,390*	64.0	20,420*
	180	57.8	20,140*	59.9	20,150*	61.8	19,740*
	190	55.6	18,160*	57.7	18,160*	59.5	18,170*
	200	53.3	16,380*	55.4	16,380*	57.2	16,390*
	210	51.0	14,780*	53.1	14,790*	54.8	14,800*
	220	48.6	13,340*	50.6	13,340*	52.3	13,350*
	230	46.0	12,030*	48.1	12,030*	49.7	12,050*
	240	43.4	10,830*	45.4	10,840*	47.0	10,850*

Boom length	Jib Radius (Feet)	5.0 Deg offset		15.0 Deg offset		25.0 Deg offset	
		Boom Angle	Rating (Pounds)	Boom Angle	Rating (Pounds)	Boom Angle	Rating (Pounds)
	58	81.9	36,570*	-	-	-	-
	60	81.5	36,570*	-	-	-	-
	70	79.8	35,660*	82.0	31,770*	-	-
	80	78.0	34,770*	80.2	31,240*	-	-
	90	76.2	33,950*	78.4	30,660*	80.4	27,910*
	100	74.3	33,180*	76.5	30,030*	78.6	27,220*
	110	72.5	32,410*	74.7	29,520*	76.7	26,680*
	120	70.6	31,760*	72.8	28,750*	74.8	25,820*
	130	68.8	30,990*	70.9	28,110*	72.9	24,660*
	140	66.8	30,350*	69.0	27,460*	70.9	23,510*
250' (76.2 m)	150	64.9	27,280*	67.0	26,930*	69.0	22,520*
	160	62.9	24,390*	65.0	24,390*	66.9	21,590*
	170	60.9	21,840*	63.0	21,840*	64.9	20,830*
	180	58.9	19,590*	61.0	19,600*	62.8	19,610*
	190	56.8	17,610*	58.8	17,610*	60.6	17,620*
	200	54.6	15,830*	56.7	15,830*	58.4	15,840*
	210	52.4	14,220*	54.4	14,230*	56.2	14,240*
	220	50.1	12,780*	52.1	12,790*	53.8	12,800*
	230	47.7	11,480*	49.7	11,480*	51.4	11,490*
	240	45.3	10,280*	47.2	10,280*	48.8	10,300*
	250	42.7	9,180*	44.6	9,190*	46.2	9,200*

	59	82.0	40,950*	-	-	-	-
	60	81.8	40,880*	-	-	-	-
	70	80.1	35,560*	-	-	-	-
	80	78.3	34,830*	80.5	31,120*	-	-
	90	76.6	33,980*	78.7	30,580*	80.7	27,880*
	100	74.8	33,260*	76.9	30,020*	78.9	27,410*
	110	73.0	32,490*	75.1	29,490*	77.1	26,760*
	120	71.2	31,860*	73.3	29,020*	75.3	26,220*
	130	69.4	31,220*	71.5	28,260*	73.4	24,950*
	140	67.6	30,130*	69.7	27,740*	71.5	23,910*
260' (79.2 m)	150	65.7	26,770*	67.8	26,770*	69.6	22,870*
	160	63.8	23,860*	65.9	23,860*	67.7	21,930*
	170	61.9	21,310*	63.9	21,320*	65.7	21,150*
	180	59.9	19,080*	61.9	19,080*	63.7	19,090*
	190	57.9	17,080*	59.9	17,090*	61.7	17,100*
	200	55.8	15,300*	57.8	15,300*	59.6	15,310*
	210	53.7	13,690*	55.7	13,700*	57.4	13,710*
	220	51.5	12,250*	53.5	12,260*	55.2	12,270*
	230	49.3	10,940*	51.2	10,950*	52.9	10,960*
	240	47.0	9,750*	48.9	9,750*	50.5	9,760*
	250	44.6	8,650*	46.4	8,660*	48.0	8,670*
	260	42.0	7,650*	43.9	7,650*	45.3	7,660*

3

WITH 92HI OFFSET TIP BOOM, #30 JIB

195,000 lb + 64,000 lb CB

360°

ANSI B 30.5

75' (22.9 m) Jib length

Boom length	Jib Radius (Feet)	5.0 Deg offset		15.0 Deg offset		25.0 Deg offset	
		Boom Angle	Rating (Pounds)	Boom Angle	Rating (Pounds)	Boom Angle	Rating (Pounds)
	61	81.9	40,500*	-	-	-	-
	70	80.4	35,600*	-	-	-	-
	80	78.7	34,750*	80.7	31,080*	-	-
	90	77.0	34,000*	79.0	30,600*	81.0	27,750*
	100	75.3	33,230*	77.3	30,120*	79.3	27,390*
	110	73.5	32,600*	75.6	29,510*	77.5	26,940*
	120	71.8	31,970*	73.8	29,110*	75.7	26,410*
	130	70.0	31,190*	72.1	28,470*	73.9	25,340*
	140	68.3	29,600	70.3	27,830*	72.1	24,200*
	150	66.5	26,240	68.5	26,250	70.3	23,180*
270' (82.3 m)	160	64.6	23,330	66.6	23,340	68.4	22,330*
	170	62.8	20,790	64.7	20,790	66.5	20,800
	180	60.9	18,550	62.8	18,550	64.6	18,560
	190	58.9	16,550	60.9	16,560	62.6	16,570
	200	57.0	14,770	58.9	14,770	60.6	14,780
	210	54.9	13,170	56.9	13,170	58.5	13,180
	220	52.9	11,720	54.8	11,730	56.4	11,740
	230	50.7	10,400	52.6	10,410	54.2	10,420
	240	48.5	9,200	50.4	9,210	52.0	9,220
	250	46.2	8,110	48.1	8,110	49.6	8,120
260	43.9	7,100	45.7	7,110	47.1	7,120	
270	41.4	6,180	43.2	6,180	44.5	6,200	

85' (25.9 m) Jib length

Boom length	Jib Radius (Feet)	5.0 Deg offset		15.0 Deg offset		25.0 Deg offset	
		Boom Angle	Rating (Pounds)	Boom Angle	Rating (Pounds)	Boom Angle	Rating (Pounds)
	56	81.9	29,950*	-	-	-	-
	60	81.1	29,570*	-	-	-	-
	70	79.2	28,600*	81.9	25,320*	-	-
	80	77.3	27,700*	80.0	24,430*	-	-
	90	75.4	26,890*	78.0	23,680*	80.6	21,040*
	100	73.4	26,170*	76.1	22,920*	78.6	20,540*
	110	71.5	25,200*	74.1	22,190*	76.5	20,040*
	120	69.5	24,270*	72.1	21,590*	74.5	19,530*
220' (67.1 m)	130	67.4	23,540*	70.0	20,990*	72.4	19,080*
	140	65.4	22,740*	68.0	20,490*	70.3	18,700*
	150	63.3	22,040*	65.9	19,900*	68.2	18,310*
	160	61.1	21,380*	63.7	19,480*	66.0	17,860*
	170	59.0	20,780*	61.5	19,040*	63.7	17,160*
	180	56.7	20,190*	59.2	18,590*	61.4	16,500*
	190	54.4	19,210	56.9	18,210*	59.1	15,940*
	200	52.0	17,430	54.5	17,430	56.6	15,370*
	210	49.6	15,830	52.0	15,830	54.1	14,880*
	220	47.0	14,390	49.4	14,390	51.4	14,410

Boom length	Jib Radius (Feet)	5.0 Deg offset		15.0 Deg offset		25.0 Deg offset	
		Boom Angle	Rating (Pounds)	Boom Angle	Rating (Pounds)	Boom Angle	Rating (Pounds)
	57	82.0	29,730*	-	-	-	-
	60	81.4	29,540*	-	-	-	-
	70	79.6	28,640*	-	-	-	-
	80	77.7	27,810*	80.3	24,580*	-	-
	90	75.9	27,040*	78.4	23,770*	80.9	21,170*
	100	74.0	26,220*	76.5	23,050*	78.9	20,560*
	110	72.1	25,490*	74.6	22,350*	77.0	20,100*
	120	70.2	24,550*	72.7	21,750*	75.0	19,670*
230' (70.1 m)	130	68.2	23,740*	70.7	21,140*	73.0	19,240*
	140	66.2	22,990*	68.7	20,640*	71.0	18,830*
	150	64.2	22,290*	66.7	20,130*	69.0	18,450*
	160	62.2	21,690*	64.6	19,620*	66.9	18,070*
	170	60.1	21,010*	62.5	19,200*	64.7	17,530*
	180	57.9	20,510*	60.4	18,790*	62.5	16,860*
	190	55.7	18,860	58.1	18,420*	60.3	16,240*
	200	53.5	17,080	55.9	17,080	57.9	15,670*
	210	51.1	15,480	53.5	15,490	55.5	15,170*
	220	48.7	14,050	51.1	14,050	53.0	14,060
230	46.2	12,730	48.5	12,730	50.4	12,750	

WITH 92HI OFFSET TIP BOOM, # 30 JIB

195,000 lb + 64,000 lb CB

360°

ANSI B 30.5

85' (25.9 m) Jib length

Boom length	Jib Radius (Feet)	5.0 Deg offset		15.0 Deg offset		25.0 Deg offset	
		Boom Angle	Rating (Pounds)	Boom Angle	Rating (Pounds)	Boom Angle	Rating (Pounds)
	59	81.9	29,690*	-	-	-	-
	60	81.7	29,570*	-	-	-	-
	70	79.9	28,760*	-	-	-	-
	80	78.1	27,870*	80.6	24,670*	-	-
	90	76.3	27,090*	78.8	23,930*	81.2	21,170*
	100	74.5	26,380*	77.0	23,190*	79.3	20,690*
	110	72.6	25,690*	75.1	22,570*	77.4	20,160*
	120	70.8	24,850*	73.2	21,900*	75.5	19,730*
240' (73.2 m)	130	68.9	24,010*	71.3	21,300*	73.6	19,290*
	140	67.0	23,300*	69.4	20,780*	71.7	18,880*
	150	65.1	22,600*	67.5	20,270*	69.7	18,580*
	160	63.1	21,940*	65.5	19,840*	67.7	18,200*
	170	61.1	21,340*	63.5	19,360*	65.6	17,820*
	180	59.0	20,320	61.4	19,000*	63.5	17,120*
	190	56.9	18,340	59.3	18,340	61.4	16,530*
	200	54.8	16,560	57.1	16,560	59.1	15,970*
	210	52.6	14,960	54.9	14,970	56.9	14,980
	220	50.3	13,510	52.6	13,520	54.5	13,530
	230	47.9	12,210	50.2	12,210	52.1	12,220
	240	45.4	11,020	47.7	11,020	49.5	11,040

	60	81.9	29,610*	-	-	-	-
	70	80.2	28,870*	-	-	-	-
	80	78.5	28,010*	80.9	24,860*	-	-
	90	76.7	27,270*	79.1	24,060*	81.4	21,250*
	100	75.0	26,540*	77.4	23,360*	79.6	20,710*
	110	73.2	25,880*	75.6	22,640*	77.8	20,300*
	120	71.4	25,130*	73.8	22,030*	76.0	19,780*
	130	69.6	24,310*	71.9	21,520*	74.1	19,380*
250' (76.2 m)	140	67.7	23,500*	70.1	20,930*	72.3	19,010*
	150	65.9	22,860*	68.2	20,420*	70.3	18,630*
	160	64.0	22,160*	66.3	20,000*	68.4	18,330*
	170	62.0	21,560*	64.3	19,500*	66.4	18,030*
	180	60.1	19,790	62.4	19,160*	64.4	17,410*
	190	58.0	17,790	60.3	17,800	62.4	16,820*
	200	56.0	16,010	58.3	16,010	60.2	16,020
	210	53.9	14,410	56.1	14,420	58.1	14,430
	220	51.7	12,960	53.9	12,970	55.8	12,980
	230	49.5	11,650	51.7	11,660	53.5	11,670
	240	47.1	10,460	49.3	10,460	51.1	10,470
	250	44.7	9,370	46.9	9,380	48.6	9,390

Boom length	Jib Radius (Feet)	5.0 Deg offset		15.0 Deg offset		25.0 Deg offset	
		Boom Angle	Rating (Pounds)	Boom Angle	Rating (Pounds)	Boom Angle	Rating (Pounds)
	62	81.8	29,520*	-	-	-	-
	70	80.5	28,860*	-	-	-	-
	80	78.8	28,160*	81.2	24,880*	-	-
	90	77.1	27,400*	79.5	24,200*	81.7	21,320*
	100	75.4	26,610*	77.7	23,440*	80.0	20,790*
	110	73.7	25,960*	76.0	22,800*	78.2	20,370*
	120	71.9	25,320*	74.3	22,190*	76.4	19,860*
	130	70.2	24,490*	72.5	21,590*	74.6	19,520*
	140	68.4	23,770*	70.7	21,080*	72.8	19,090*
	150	66.6	23,060*	68.9	20,570*	71.0	18,760*
260' (79.2 m)	160	64.8	22,410*	67.0	20,150*	69.1	18,380*
	170	62.9	21,500	65.2	19,720*	67.2	18,080*
	180	61.0	19,260	63.3	19,260	65.3	17,700*
	190	59.1	17,260	61.3	17,270	63.3	17,080*
	200	57.1	15,490	59.3	15,490	61.3	15,510
	210	55.1	13,890	57.3	13,890	59.2	13,900
	220	53.0	12,430	55.2	12,440	57.1	12,450
	230	50.9	11,120	53.0	11,130	54.9	11,140
	240	48.7	9,920	50.8	9,930	52.6	9,940
	250	46.4	8,840	48.5	8,840	50.2	8,850
	260	44.0	7,830	46.1	7,840	47.8	7,850

	63	81.9	29,470*	-	-	-	-
	70	80.8	28,890*	-	-	-	-
	80	79.1	28,100*	81.4	24,780*	-	-
	90	77.5	27,400*	79.8	24,230*	81.9	21,340*
	100	75.8	26,690*	78.1	23,620*	80.2	20,850*
	110	74.2	26,050*	76.4	22,910*	78.5	20,430*
	120	72.5	25,500*	74.7	22,350*	76.8	20,010*
	130	70.8	24,780*	73.0	21,750*	75.1	19,580*
	140	69.0	24,060*	71.3	21,230*	73.3	19,150*
	150	67.3	23,330*	69.5	20,720*	71.6	18,810*
270' (82.3 m)	160	65.5	22,720*	67.7	20,290*	69.8	18,510*
	170	63.7	20,980	65.9	19,880*	67.9	18,210*
	180	61.9	18,730	64.1	18,740	66.1	17,920*
	190	60.0	16,740	62.2	16,740	64.2	16,750
	200	58.2	14,950	60.3	14,960	62.2	14,970
	210	56.2	13,360	58.4	13,360	60.2	13,370
	220	54.2	11,900	56.4	11,910	58.2	11,920
	230	52.2	10,590	54.3	10,600	56.1	10,610
	240	50.1	9,390	52.2	9,400	53.9	9,410
	250	47.9	8,290	50.0	8,300	51.7	8,310
	260	45.7	7,290	47.7	7,290	49.4	7,310
	270	43.3	6,360	45.3	6,370	47.0	6,380

3

WITH 92HI OFFSET TIP BOOM, #30 JIB

195,000 lb + 64,000 lb CB

360°

ANSI B 30.5

95' (29.0 m) Jib length

Boom length	Jib Radius (Feet)	5.0 Deg offset		15.0 Deg offset		25.0 Deg offset	
		Boom Angle	Rating (Pounds)	Boom Angle	Rating (Pounds)	Boom Angle	Rating (Pounds)
	61	81.9	24,720*	-	-	-	-
	70	80.4	23,920*	-	-	-	-
	80	78.6	23,200*	81.3	19,790*	-	-
	90	76.9	22,440*	79.6	19,150*	-	-
	100	75.1	21,540*	77.8	18,480*	80.4	16,260*
	110	73.3	20,730*	76.0	17,880*	78.5	15,830*
	120	71.5	19,960*	74.2	17,330*	76.7	15,450*
	130	69.7	19,250*	72.4	16,880*	74.8	15,060*
240' (73.2 m)	140	67.9	18,600*	70.5	16,360*	73.0	14,690*
	150	66.0	17,990*	68.6	15,910*	71.1	14,380*
	160	64.1	17,370*	66.7	15,540*	69.1	14,120*
	170	62.2	16,850*	64.8	15,160*	67.1	13,810*
	180	60.2	16,400*	62.8	14,790*	65.1	13,540*
	190	58.2	15,910*	60.8	14,420*	63.0	13,330*
	200	56.1	15,460*	58.7	14,110*	60.9	13,120*
	210	54.0	15,070*	56.5	13,860*	58.8	12,920*
	220	51.8	13,630*	54.4	13,540*	56.5	12,710*
	230	49.6	12,320*	52.1	12,330*	54.2	12,340*
	240	47.3	11,130*	49.7	11,130*	51.8	11,150*

	62	82.0	24,650*	-	-	-	-
	70	80.6	24,100*	-	-	-	-
	80	79.0	23,360*	81.6	19,870*	-	-
	90	77.3	22,650*	79.9	19,220*	-	-
	100	75.6	21,740*	78.2	18,630*	80.7	16,290*
	110	73.8	20,960*	76.4	18,010*	78.9	15,860*
	120	72.1	20,190*	74.7	17,480*	77.1	15,480*
	130	70.3	19,420*	72.9	17,000*	75.3	15,100*
250' (76.2 m)	140	68.5	18,810*	71.1	16,540*	73.5	14,790*
	150	66.7	18,190*	69.3	16,090*	71.7	14,480*
	160	64.9	17,590*	67.5	15,650*	69.8	14,160*
	170	63.0	17,070*	65.6	15,270*	67.9	13,900*
	180	61.2	16,580*	63.7	14,890*	65.9	13,620*
	190	59.2	16,140*	61.7	14,580*	64.0	13,420*
	200	57.2	15,690*	59.7	14,260*	61.9	13,200*
	210	55.2	14,530*	57.7	13,940*	59.9	13,000*
	220	53.2	13,080*	55.6	13,090*	57.7	12,790*
	230	51.0	11,770*	53.4	11,780*	55.5	11,790*
	240	48.8	10,570*	51.2	10,580*	53.2	10,590*
	250	46.5	9,480*	48.9	9,480*	50.9	9,500*

Boom length	Jib Radius (Feet)	5.0 Deg offset		15.0 Deg offset		25.0 Deg offset	
		Boom Angle	Rating (Pounds)	Boom Angle	Rating (Pounds)	Boom Angle	Rating (Pounds)
	64	81.9	24,540*	-	-	-	-
	70	80.9	24,100*	-	-	-	-
	80	79.3	23,430*	81.8	19,960*	-	-
	90	77.6	22,670*	80.2	19,300*	-	-
	100	76.0	21,960*	78.5	18,680*	80.9	16,360*
	110	74.3	21,110*	76.8	18,140*	79.2	15,970*
	120	72.6	20,340*	75.1	17,600*	77.5	15,590*
	130	70.9	19,650*	73.4	17,070*	75.8	15,210*
	140	69.2	18,970*	71.7	16,620*	74.0	14,830*
	150	67.4	18,410*	69.9	16,200*	72.2	14,570*
260' (79.2 m)	160	65.7	17,800*	68.1	15,750*	70.4	14,250*
	170	63.9	17,260*	66.3	15,370*	68.6	13,960*
	180	62.0	16,810*	64.5	15,050*	66.7	13,710*
	190	60.2	16,360*	62.6	14,690*	64.8	13,500*
	200	58.3	15,600*	60.7	14,380*	62.9	13,230*
	210	56.4	14,000*	58.8	14,000*	60.9	13,030*
	220	54.4	12,550*	56.8	12,550*	58.8	12,570*
	230	52.3	11,240*	54.7	11,250*	56.7	11,260*
	240	50.2	10,040*	52.6	10,050*	54.6	10,060*
	250	48.1	8,940*	50.4	8,950*	52.3	8,960*
	260	45.8	7,950*	48.1	7,950*	50.0	7,970*

	65	82.0	24,540*	-	-	-	-
	70	81.2	24,190*	-	-	-	-
	80	79.6	23,490*	-	-	-	-
	90	78.0	22,780*	80.5	19,370*	-	-
	100	76.4	22,120*	78.8	18,820*	81.2	16,400*
	110	74.7	21,260*	77.2	18,200*	79.5	16,020*
	120	73.1	20,570*	75.6	17,730*	77.9	15,630*
	130	71.4	19,890*	73.9	17,200*	76.2	15,250*
	140	69.8	19,190*	72.2	16,740*	74.5	14,930*
	150	68.1	18,620*	70.5	16,290*	72.8	14,610*
270' (82.3 m)	160	66.4	18,000*	68.8	15,910*	71.0	14,310*
	170	64.6	17,470*	67.0	15,540*	69.2	14,060*
	180	62.9	16,990*	65.3	15,160*	67.4	13,800*
	190	61.1	16,540*	63.5	14,850*	65.6	13,580*
	200	59.3	15,070*	61.6	14,540*	63.7	13,320*
	210	57.4	13,470*	59.8	13,470*	61.8	13,110*
	220	55.5	12,020*	57.8	12,030*	59.9	12,040*
	230	53.5	10,710*	55.9	10,720*	57.9	10,730*
	240	51.5	9,510*	53.8	9,520*	55.8	9,530*
	250	49.5	8,410*	51.8	8,420*	53.7	8,430*
	260	47.3	7,400*	49.6	7,410*	51.5	7,420*
	270	45.1	6,480*	47.4	6,480*	49.2	6,500*

NOTES TO LIFTING CAPACITY

Warning

This rating chart is invalid if the crane has been modified or altered by use of other than GENUINE AMERICAN PARTS as such modifications or alterations may affect its capacity or safe operation. See American Crane Corporation Service Bulletin #259.

Ratings in this chart are in POUNDS and do not exceed the percentage of tipping specified for this crane by ANSI B30.5. All ratings require that the crane be standing level on a firm uniformly supporting surface.

Do not lift loads in excess of those shown on this chart. Lifting loads in excess of those shown or operation not in accordance with good operating practice, including limitations shown on page 3499 of Operator's Manual, can cause tipping, structural damage or catastrophic failure.

Asterisk (*) areas on this chart indicate ratings which are limited by strength of material or factors other than stability (tipping).

„RADIUS IN FEET“ is the horizontal distance at ground level from the crane centerline of rotation to a vertical line through the center of gravity of the suspended load.

When using the main boom fall with jib in place, the main fall ratings must be reduced by the jib effective weight shown on the jib rating chart plus twice the weight of all suspended blocks, slings, rope, etc., at the jib fall. See Appendix A.

Blocks, slings, buckets and other load carrying devices are considered part of the load. The weight of standard hoisting ropes for the rating at a given radius has been calculated as part of the boom point load and need not be considered in determining net allowable loads. See Appendix A.

Ratings shown on this chart make no allowance for such factors as out of plumb loads, wind, poor soil conditions and dynamic effects due to excessive operating speeds. The user (operator) must exercise judgement to make allowance for these conditions. See page 3499 of Operator's Manual for detailed information.

No account is taken of the wind force on the load. This effect, which can be substantial for loads with large surface areas, must be considered by the user. In any wind it is strongly recommended that taglines be used to control the load.

Combinations of boom or boom and jib with a total length exceeding 350 ft (107 m) can be operated at full rated capacity only in wind speeds of 15 mph (24 km/h) or less. If lifts are to be performed in winds between 15 mph (24 km/h) and 25 mph (40 km/h), ratings must be reduced 10%. No operation of the above combinations should be attempted in wind speeds over 40 km/h (25 mph). The above limitations do not take into account loads with excessive surface area which are not restrained by tag lines.

BOOM HOIST LINE is 18 parts of 7/8 inch diameter 6 x 26, WS, FW, RAL, IWRC, EIPS wire rope with a minimum breaking strength of 79,600 pounds.

BOOM PENDANT SUSPENSION is 4 parts of 1-3/8 inch diameter EEIPS wire rope with a minimum breaking strength of 211,000 pounds.

JIB BACKSTAY LINE is 1.0 inch diameter wire rope with a minimum breaking strength of 115,000 pounds.

JIB FRONTSTAY PENDANT SUSPENSION is 2 parts of 1.0 inch diameter wire rope with a minimum breaking strength of 115,000 pounds.

WHIPLINE is 1-1/8 inch diameter 6 x 25, FW, RRL, IWRC, EEIPS wire rope with a minimum breaking strength of 143,000 pounds.

ERECTION

Erection „BLOCKED OVER THE END“ is with the boom over the idler end with idler tumbler blocked (See operator's manual for blocking instructions). Erection „OVER THE SIDE“ is with the boom 90° to the side frames. Blocks, slings and other load carrying devices must be on the ground during erection.

LOAD HOISTING INFORMATION - 1-1/8 inch diameter EEIPS wire rope			
MAXIMUM LIFTING CAPACITY - LBS.	MINIMUM PARTS OF LINE	MAXIMUM HOISTING DISTANCE - FEET	
		MAIN HOIST	AUX HOIST
60,000	2	655	655
40,850	1	1,310	1,310

92HI OFFSET TIP BOOM MAXIMUM BOOM & JIB SELF-ERECTION DATA		
	BOOM LENGTH (FEET)	JIB LENGTH
		#30 JIB (FEET)
BLOCKED OVER THE END	300	0
	290	0
	280	65
	270	95
OVER THE SIDE	280	0
	270	0
	260	35
	250	65
	240	95

BOOM COMPOSITION CHART - 92HI OFFSET TIP						
BOOM LENGTH (FEET)	BOOM SECTIONS					
	25' 92HI INNER	15' 92HT CENTER	20' 92HT CENTER	10' 92ST CENTER	50' 92ST CENTER	40' 92H OUTER
90	1	1	0	1	0	1
100	1	1	1	0	0	1
110	1	1	1	1	0	1
120	1	1	1	2	0	1
130	1	1	0	0	1	1
140	1	1	0	1	1	1
150	1	1	1	0	1	1
160	1	1	1	1	1	1
170	1	1	1	2	1	1
180	1	1	0	0	2	1
190	1	1	0	1	2	1
200	1	1	1	0	2	1
210	1	1	1	1	2	1
220	1	1	1	2	2	1
230	1	1	0	0	3	1
240	1	1	0	1	3	1
250	1	1	1	0	3	1
260	1	1	1	1	3	1
270	1	1	1	2	3	1
280	1	1	0	0	4	1

#30 JIB COMPOSITION CHART								
JIB LENGTH (FEET)	12.5' 32	10' 32	30' 32	12.5' 32	EFF. JIB WEIGHT (POUNDS)	JIB OFFSET "A" IN FEET		
	INNER	CENTER	CENTER	OUTER		5'	15'	25'
35	1	1	0	1	5,430	4.7	9.1	13.4
45	1	2	0	1	6,020	5.4	11.0	16.6
55	1	0	1	1	6,360	6.0	12.9	19.6
65	1	1	1	1	6,900	6.6	14.8	22.8
75	1	2	1	1	7,480	7.3	16.6	25.8
85	1	0	2	1	7,750	7.9	18.5	29.0
95	1	1	2	1	8,440	8.5	20.3	31.9

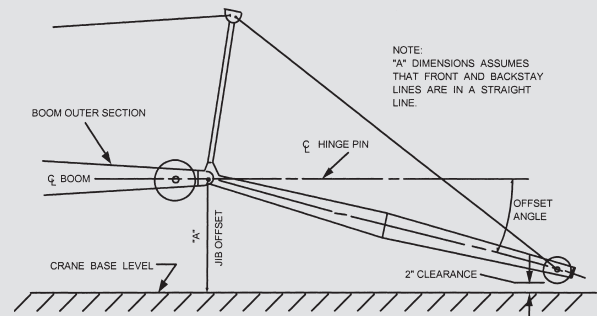

RANGE DIAGRAM, 16HL JIB

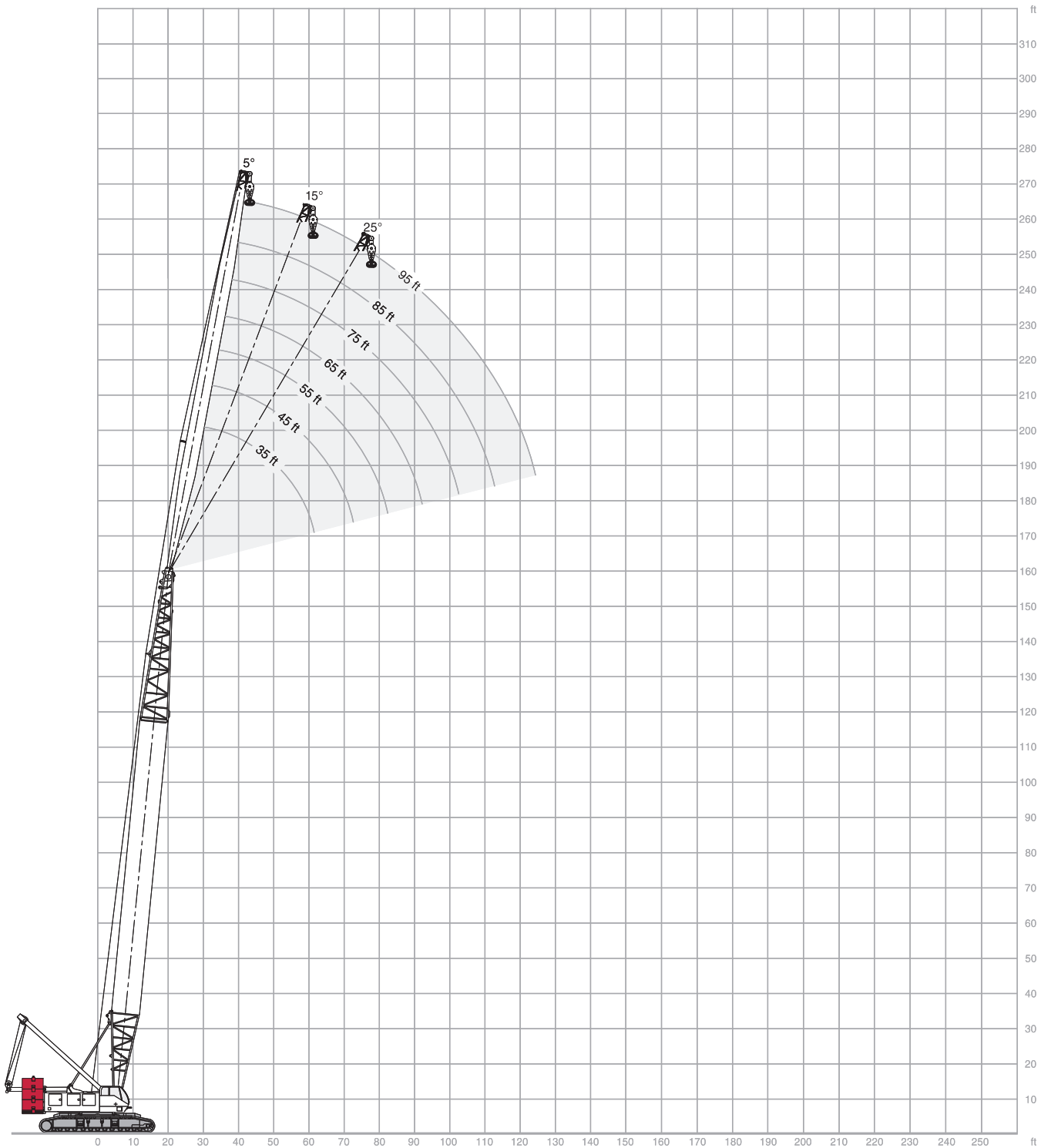

WITH 92HI OFFSET TIP BOOM, 16HL JIB

195,000 lb + 64,000 lb CB

360°

ANSI B 30.5

40' (12.2 m) Jib length

Boom length	Jib Radius (Feet)	5.0 Deg offset		15.0 Deg offset		25.0 Deg offset	
		Boom Angle	Rating (Pounds)	Boom Angle	Rating (Pounds)	Boom Angle	Rating (Pounds)
	28	82.0	32,000*	-	-	-	-
	30	81.2	32,000*	-	-	-	-
	35	79.1	32,000*	81.8	32,000*	-	-
	40	77.0	32,000*	79.7	32,000*	-	-
100' (30.5 m)	50	72.8	32,000*	75.5	32,000*	78.0	30,670*
	60	68.5	32,000*	71.2	32,000*	73.6	27,430*
	70	64.0	32,000*	66.7	32,000*	69.1	24,910*
	80	59.4	32,000*	62.0	29,470*	64.3	22,820*
	90	54.5	31,700*	57.0	26,670*	59.3	21,190*
	100	49.3	28,690*	51.8	24,440*	53.9	19,820*

	30	81.8	32,000*	-	-	-	-
	35	79.8	32,000*	-	-	-	-
	40	77.9	32,000*	80.4	32,000*	-	-
	50	74.0	32,000*	76.5	32,000*	78.9	31,340*
110' (33.5 m)	60	70.0	32,000*	72.5	32,000*	74.8	28,110*
	70	65.9	32,000*	68.3	32,000*	70.6	25,570*
	80	61.6	32,000*	64.1	30,800*	66.2	23,580*
	90	57.2	32,000*	59.6	27,890*	61.7	21,870*
	100	52.5	30,320*	54.8	25,620*	56.9	20,550*
	110	47.5	27,820*	49.8	23,760*	51.7	19,370*

	31	81.9	32,000*	-	-	-	-
	35	80.5	32,000*	-	-	-	-
	40	78.7	32,000*	81.0	32,000*	-	-
	50	75.0	32,000*	77.4	32,000*	79.6	31,870*
120' (36.6 m)	60	71.3	32,000*	73.6	32,000*	75.8	28,830*
	70	67.5	32,000*	69.8	32,000*	71.9	26,330*
	80	63.6	32,000*	65.8	32,000*	67.9	24,280*
	90	59.5	32,000*	61.7	29,170*	63.7	22,510*
	100	55.2	32,000*	57.4	26,840*	59.4	21,180*
	110	50.7	29,310*	52.9	24,830*	54.7	19,940*
	120	45.9	27,090*	48.0	23,210*	49.7	18,970*

	33	81.7	32,000*	-	-	-	-
	35	81.0	32,000*	-	-	-	-
	40	79.3	32,000*	81.6	32,000*	-	-
	50	75.9	32,000*	78.1	32,000*	80.2	32,000*
130' (39.6 m)	60	72.4	32,000*	74.6	32,000*	76.7	29,380*
	70	68.9	32,000*	71.0	32,000*	73.1	26,940*
	80	65.2	32,000*	67.4	32,000*	69.3	24,910*
	90	61.4	32,000*	63.6	30,420*	65.5	23,180*
	100	57.5	32,000*	59.6	27,890*	61.5	21,730*
	110	53.4	30,920*	55.5	25,900*	57.3	20,510*
	120	49.1	28,400*	51.1	24,090*	52.8	19,550*
	130	44.4	26,400*	46.4	22,670*	48.0	18,690*

	34	81.8	32,000*	-	-	-	-
	35	81.5	32,000*	-	-	-	-
	40	79.9	32,000*	-	-	-	-
	50	76.7	32,000*	78.8	32,000*	80.8	32,000*
	60	73.4	32,000*	75.5	32,000*	77.5	29,930*
	70	70.1	32,000*	72.2	32,000*	74.1	27,510*
140' (42.7 m)	80	66.7	32,000*	68.7	32,000*	70.6	25,480*
	90	63.2	32,000*	65.2	31,530*	67.0	23,770*
	100	59.5	32,000*	61.5	28,920*	63.3	22,360*
	110	55.8	32,000*	57.7	26,840*	59.4	21,100*
	120	51.8	29,900*	53.7	25,050*	55.4	20,060*
	130	47.6	27,730*	49.5	23,540*	51.1	19,140*
	140	43.1	25,860*	44.9	22,270*	46.4	18,380*

Boom length	Jib Radius (Feet)	5.0 Deg offset		15.0 Deg offset		25.0 Deg offset	
		Boom Angle	Rating (Pounds)	Boom Angle	Rating (Pounds)	Boom Angle	Rating (Pounds)
	35	82.0	32,000*	-	-	-	-
	40	80.5	32,000*	-	-	-	-
	50	77.4	32,000*	79.4	32,000*	81.3	32,000*
	60	74.3	32,000*	76.3	32,000*	78.1	30,460*
	70	71.2	32,000*	73.1	32,000*	74.9	28,070*
	80	68.0	32,000*	69.9	32,000*	71.7	26,030*
150' (45.7 m)	90	64.7	32,000*	66.6	32,000*	68.3	24,300*
	100	61.3	32,000*	63.2	30,030*	64.9	22,810*
	110	57.8	32,000*	59.7	27,810*	61.3	21,610*
	120	54.1	31,290*	56.0	25,990*	57.6	20,530*
	130	50.3	29,020*	52.1	24,460*	53.7	19,620*
	140	46.2	27,050*	48.0	23,100*	49.5	18,880*
	150	41.9	25,430*	43.6	21,930*	44.9	18,220*

	37	81.8	32,000*	-	-	-	-
	40	80.9	32,000*	-	-	-	-
	50	78.0	32,000*	79.9	32,000*	81.7	32,000*
	60	75.1	32,000*	77.0	32,000*	78.8	31,030*
	70	72.1	32,000*	74.0	32,000*	75.7	28,620*
	80	69.1	32,000*	71.0	32,000*	72.7	26,540*
160' (48.8 m)	90	66.0	32,000*	67.9	32,000*	69.5	24,790*
	100	62.9	32,000*	64.7	31,040*	66.3	23,340*
	110	59.6	32,000*	61.4	28,840*	63.0	22,150*
	120	56.2	32,000*	58.0	26,860*	59.5	21,030*
	130	52.7	30,320*	54.4	25,290*	55.9	20,090*
	140	48.9	28,300*	50.7	23,910*	52.1	19,270*
	150	45.0	26,570*	46.7	22,660*	48.0	18,610*
	160	40.8	25,050*	42.4	21,660*	43.6	18,040*

	38	81.9	32,000*	-	-	-	-
	40	81.4	32,000*	-	-	-	-
	50	78.6	32,000*	80.4	32,000*	-	-
	60	75.8	32,000*	77.6	32,000*	79.3	31,380*
	70	73.0	32,000*	74.8	32,000*	76.5	29,030*
	80	70.1	32,000*	71.9	32,000*	73.5	27,030*
170' (51.8 m)	90	67.2	32,000*	69.0	32,000*	70.6	25,360*
	100	64.2	32,000*	66.0	32,000*	67.5	23,860*
	110	61.2	32,000*	62.9	29,730*	64.4	22,550*
	120	58.0	32,000*	59.7	27,740*	61.2	21,480*
	130	54.7	31,490*	56.4	26,130*	57.8	20,560*
	140	51.3	29,460*	52.9	24,700*	54.3	19,710*
	150	47.7	27,650*	49.3	23,420*	50.6	18,960*
	160	43.9	26,030*	45.4	22,350*	46.7	18,370*
	170	39.7	24,710*	41.3	21,370*	42.4	17,880*

	40	81.8	32,000*	-	-	-	-
	50	79.1	32,000*	80.9	32,000*	-	-
	60	76.5	32,000*	78.2	32,000*	79.8	31,900*
	70	73.8	32,000*	75.5	32,000*	77.1	29,550*
	80	71.1	32,000*	72.8	32,000*	74.3	27,460*
	90	68.3	32,000*	70.0	32,000*	71.5	25,840*
180' (54.9 m)	100	65.5	32,000*	67.2	32,000*	68.6	24,340*
	110	62.6	32,000*	64.2	30,600*	65.7	23,050*
	120	59.6	32,000*	61.2	28,630*	62.7	21,920*
	130	56.5	32,000*	58.2	26,970*	59.5	20,990*
	140	53.4	30,580*	54.9	25,380*	56.3	20,060*
	150	50.0	28,800*	51.6	24,080*	52.9	19,330*
	160	46.5	27,160*	48.1	22,950*	49.3	18,690*
	170	42.8	25,310	44.3	22,010*	45.4	18,120*
	180	38.8	23,120	40.2	21,090*	41.3	17,720*

4

WITH 92HI OFFSET TIP BOOM, 16HL JIB

195,000 lb + 64,000 lb CB

360°

ANSI B 30.5

40' (12.2 m) Jib length

Boom length	Jib Radius (Feet)	5.0 Deg offset Boom Angle	5.0 Deg offset Rating (Pounds)	15.0 Deg offset Boom Angle	15.0 Deg offset Rating (Pounds)	25.0 Deg offset Boom Angle	25.0 Deg offset Rating (Pounds)
	41	81.9	32,000*	-	-	-	-
	50	79.6	32,000*	81.3	32,000*	-	-
	60	77.1	32,000*	78.7	32,000*	80.3	32,000*
	70	74.5	32,000*	76.2	32,000*	77.7	29,920*
	80	71.9	32,000*	73.6	32,000*	75.0	27,900*
	90	69.3	32,000*	70.9	32,000*	72.4	26,270*
190' (57.9 m)	100	66.6	32,000*	68.2	32,000*	69.7	24,770*
	110	63.9	32,000*	65.5	31,500*	66.9	23,470*
	120	61.1	32,000*	62.6	29,410*	64.0	22,360*
	130	58.2	32,000*	59.7	27,680*	61.1	21,370*
	140	55.2	31,780*	56.7	26,220*	58.0	20,480*
	150	52.1	29,840*	53.6	24,840*	54.9	19,720*
	160	48.9	27,270	50.3	23,620*	51.5	19,050*
	170	45.4	24,760	46.9	22,640*	48.0	18,490*
	180	41.8	22,560	43.2	21,730*	44.3	18,020*
	190	37.9	20,620	39.2	20,630	40.2	17,590*

	42	82.0	32,000*	-	-	-	-
	50	80.0	32,000*	81.6	32,000*	-	-
	60	77.6	32,000*	79.2	32,000*	80.7	32,000*
	70	75.2	32,000*	76.8	32,000*	78.2	30,350*
	80	72.7	32,000*	74.3	32,000*	75.7	28,360*
	90	70.2	32,000*	71.7	32,000*	73.2	26,650*
	100	67.6	32,000*	69.2	32,000*	70.6	25,160*
	110	65.0	32,000*	66.6	32,000*	67.9	23,930*
200' (61.0 m)	120	62.4	32,000*	63.9	30,230*	65.2	22,730*
	130	59.7	32,000*	61.1	28,480*	62.4	21,770*
	140	56.8	32,000*	58.3	26,890*	59.6	20,910*
	150	53.9	29,560	55.4	25,490*	56.6	20,090*
	160	50.9	26,690	52.3	24,300*	53.5	19,380*
	170	47.8	24,190	49.2	23,220*	50.3	18,800*
	180	44.4	21,980	45.8	21,980	46.9	18,260*
	190	40.9	20,030	42.2	20,030	43.2	17,810*
	200	37.0	18,290	38.3	18,300	39.3	17,450*

	44	81.8	32,000*	-	-	-	-
	50	80.4	32,000*	82.0	32,000*	-	-
	60	78.1	32,000*	79.6	32,000*	81.1	32,000*
	70	75.8	32,000*	77.3	32,000*	78.7	30,690*
	80	73.4	32,000*	74.9	32,000*	76.3	28,780*
	90	71.0	32,000*	72.5	32,000*	73.9	27,090*
	100	68.6	32,000*	70.1	32,000*	71.4	25,630*
	110	66.1	32,000*	67.6	32,000*	68.9	24,270*
210' (64.0 m)	120	63.6	32,000*	65.0	31,010*	66.3	23,180*
	130	61.0	32,000*	62.4	29,260*	63.7	22,170*
	140	58.3	32,000*	59.8	27,670*	61.0	21,300*
	150	55.6	29,020	57.0	26,200*	58.2	20,500*
	160	52.8	26,150	54.1	24,950*	55.3	19,740*
	170	49.8	23,640	51.2	23,640	52.3	19,130*
	180	46.7	21,430	48.1	21,440	49.1	18,550*
	190	43.5	19,470	44.8	19,470	45.8	18,080*
	200	40.0	17,730	41.3	17,740	42.2	17,720*
	210	36.2	16,170	37.5	16,180	38.3	16,200

Boom length	Jib Radius (Feet)	5.0 Deg offset Boom Angle	5.0 Deg offset Rating (Pounds)	15.0 Deg offset Boom Angle	15.0 Deg offset Rating (Pounds)	25.0 Deg offset Boom Angle	25.0 Deg offset Rating (Pounds)
	45	81.9	32,000*	-	-	-	-
	50	80.8	32,000*	-	-	-	-
	60	78.6	32,000*	80.1	32,000*	81.4	32,000
	70	76.3	32,000*	77.8	32,000*	79.1	31,000
	80	74.1	32,000*	75.5	32,000*	76.8	29,160
	90	71.8	32,000*	73.2	32,000*	74.5	27,440
	100	69.4	32,000*	70.9	32,000*	72.2	26,050
	110	67.1	32,000*	68.5	32,000*	69.8	24,670
220' (67.1 m)	120	64.7	32,000*	66.1	31,910*	67.3	23,520
	130	62.2	32,000*	63.6	29,980*	64.8	22,510
	140	59.7	31,800	61.1	28,360*	62.3	21,630
	150	57.1	28,480	58.4	26,850*	59.6	20,770
	160	54.4	25,600	55.8	25,600	56.9	20,070
	170	51.7	23,080	53.0	23,090	54.1	19,450
	180	48.8	20,860	50.1	20,870	51.1	18,910
	190	45.8	18,910	47.0	18,920	48.1	18,360
	200	42.6	17,170	43.8	17,180	44.8	17,190
	210	39.2	15,600	40.4	15,610	41.3	15,630
	220	35.5	14,200	36.7	14,210	37.5	14,220

	47	81.8	32,000*	-	-	-	-
	50	81.2	32,000*	-	-	-	-
	60	79.0	32,000*	80.4	32,000*	81.7	32,000
	70	76.9	32,000*	78.3	32,000*	79.6	31,380
	80	74.7	32,000*	76.1	32,000*	77.4	29,500
	90	72.5	32,000*	73.9	32,000*	75.1	27,790
	100	70.2	32,000*	71.6	32,000*	72.9	26,310
	110	68.0	32,000*	69.3	32,000*	70.6	25,090
230' (70.1 m)	120	65.7	32,000*	67.0	32,000*	68.2	23,870
	130	63.3	32,000*	64.7	30,760*	65.8	22,850
	140	60.9	31,470	62.2	29,060*	63.4	21,960
	150	58.5	28,140	59.8	27,570*	60.9	21,130
	160	55.9	25,260	57.2	25,270	58.3	20,400
	170	53.3	22,760	54.6	22,760	55.7	19,770
	180	50.6	20,540	51.9	20,550	52.9	19,160
	190	47.8	18,570	49.1	18,580	50.1	18,590
	200	44.9	16,830	46.1	16,840	47.0	16,850
	210	41.7	15,260	42.9	15,270	43.8	15,280
	220	38.4	13,860	39.6	13,870	40.4	13,880
	230	34.8	12,590	35.9	12,600	36.7	12,620

	48	81.9	32,000*	-	-	-	-
	50	81.5	32,000*	-	-	-	-
	60	79.4	32,000*	80.8	32,000*	-	-
	70	77.3	32,000*	78.7	32,000*	79.9	31,640
	80	75.2	32,000*	76.6	32,000*	77.8	29,840
	90	73.1	32,000*	74.4	32,000*	75.7	28,170
	100	71.0	32,000*	72.3	32,000*	73.5	26,690
	110	68.8	32,000*	70.1	32,000*	71.3	25,370
	120	66.6	32,000*	67.9	32,000*	69.1	24,250
	130	64.3	32,000*	65.6	31,430*	66.8	23,200
240' (73.2 m)	140	62.0	30,950	63.3	29,770*	64.5	22,320
	150	59.7	27,610	61.0	27,620	62.1	21,460
	160	57.3	24,730	58.6	24,740	59.6	20,770
	170	54.8	22,220	56.1	22,220	57.1	20,070
	180	52.3	20,000	53.5	20,010	54.5	19,440
	190	49.6	18,040	50.9	18,050	51.8	18,060
	200	46.9	16,280	48.1	16,290	49.0	16,300
	210	44.0	14,720	45.2	14,730	46.1	14,740
	220	40.9	13,300	42.1	13,310	43.0	13,330
	230	37.7	12,030	38.8	12,040	39.6	12,060
	240	34.2	10,880	35.2	10,890	36.0	10,910

WITH 92HI OFFSET TIP BOOM, 16HL JIB

195,000 lb + 64,000 lb CB

360°

ANSI B 30.5

40' (12.2 m) Jib length

Boom length	Jib Radius (Feet)	5.0 Deg offset Boom Angle	5.0 Deg offset Rating (Pounds)	15.0 Deg offset Boom Angle	15.0 Deg offset Rating (Pounds)	25.0 Deg offset Boom Angle	25.0 Deg offset Rating (Pounds)
	49	82.0	32,000*	-	-	-	-
	50	81.8	32,000*	-	-	-	-
	60	79.8	32,000*	81.1	32,000*	-	-
	70	77.8	32,000*	79.1	32,000*	80.3	32,000*
	80	75.7	32,000*	77.0	32,000*	78.3	30,190*
	90	73.7	32,000*	75.0	32,000*	76.2	28,550*
	100	71.6	32,000*	72.9	32,000*	74.1	27,060*
	110	69.6	32,000*	70.8	32,000*	72.0	25,740*
	120	67.4	32,000*	68.7	32,000*	69.8	24,560*
	130	65.3	32,000*	66.5	32,000*	67.7	23,590*
250' (76.2 m)	140	63.1	30,390	64.3	30,340*	65.4	22,600*
	150	60.9	27,050	62.1	27,060	63.2	21,770*
	160	58.6	24,170	59.8	24,170	60.8	21,050*
	170	56.2	21,650	57.4	21,660	58.5	20,400*
	180	53.8	19,430	55.0	19,440	56.0	19,450
	190	51.3	17,470	52.5	17,480	53.5	17,490
	200	48.7	15,710	49.9	15,720	50.8	15,730
	210	46.0	14,140	47.2	14,150	48.1	14,160
	220	43.2	12,720	44.3	12,730	45.2	12,740
	230	40.2	11,450	41.3	11,450	42.1	11,470
	240	37.0	10,290	38.1	10,300	38.8	10,310
	250	33.5	9,230	34.6	9,240	35.2	9,260

	51	81.9	32,000*	-	-	-	-
	60	80.1	32,000*	81.4	32,000*	-	-
	70	78.2	32,000*	79.4	32,000*	80.6	32,000*
	80	76.2	32,000*	77.5	32,000*	78.7	30,420*
	90	74.3	32,000*	75.5	32,000*	76.7	28,790*
	100	72.3	32,000*	73.5	32,000*	74.7	27,420*
	110	70.3	32,000*	71.5	32,000*	72.6	26,050*
	120	68.2	32,000*	69.5	32,000*	70.6	24,950*
	130	66.2	32,000*	67.4	32,000*	68.5	23,860*
	140	64.1	29,850	65.3	29,860	66.3	22,930*
260' (79.2 m)	150	61.9	26,520	63.1	26,520	64.2	22,100*
	160	59.7	23,630	60.9	23,640	61.9	21,370*
	170	57.5	21,110	58.7	21,120	59.7	20,660*
	180	55.2	18,890	56.4	18,890	57.3	18,900
	190	52.8	16,920	54.0	16,930	54.9	16,940
	200	50.4	15,170	51.5	15,170	52.4	15,190
	210	47.8	13,590	49.0	13,600	49.9	13,610
	220	45.2	12,170	46.3	12,180	47.2	12,200
	230	42.4	10,890	43.5	10,900	44.3	10,920
	240	39.5	9,730	40.5	9,740	41.3	9,750
	250	36.4	8,670	37.4	8,680	38.1	8,700
	260	33.0	7,710	33.9	7,720	34.6	7,740

Boom length	Jib Radius (Feet)	5.0 Deg offset Boom Angle	5.0 Deg offset Rating (Pounds)	15.0 Deg offset Boom Angle	15.0 Deg offset Rating (Pounds)	25.0 Deg offset Boom Angle	25.0 Deg offset Rating (Pounds)
	52	81.9	32,000*	-	-	-	-
	60	80.4	32,000*	81.7	32,000*	-	-
	70	78.6	32,000*	79.8	32,000*	80.9	32,000*
	80	76.7	32,000*	77.9	32,000*	79.0	30,770*
	90	74.8	32,000*	76.0	32,000*	77.1	29,160*
	100	72.9	32,000*	74.1	32,000*	75.2	27,660*
	110	70.9	32,000*	72.1	32,000*	73.2	26,420*
	120	69.0	32,000*	70.2	32,000*	71.2	25,190*
	130	67.0	32,000*	68.2	32,000*	69.2	24,180*
	140	64.9	29,310	66.1	29,320	67.2	23,310*
270' (82.3 m)	150	62.9	25,970	64.1	25,980	65.1	22,390*
	160	60.8	23,090	62.0	23,100	63.0	21,610*
	170	58.7	20,570	59.8	20,570	60.8	20,590
	180	56.5	18,350	57.6	18,350	58.6	18,370
	190	54.2	16,370	55.3	16,380	56.3	16,390
	200	51.9	14,620	53.0	14,620	53.9	14,640
	210	49.5	13,040	50.6	13,040	51.5	13,060
	220	47.0	11,620	48.1	11,630	48.9	11,640
	230	44.4	10,340	45.5	10,340	46.3	10,360
	240	41.7	9,170	42.7	9,170	43.5	9,190
	250	38.8	8,100	39.8	8,110	40.6	8,130
	260	35.7	7,140	36.7	7,150	37.4	7,160
	270	32.4	6,250	33.4	6,260	33.9	6,280

	54	81.8	32,000*	-	-	-	-
	60	80.7	32,000*	81.9	32,000*	-	-
	70	78.9	32,000*	80.1	32,000*	81.2	32,000*
	80	77.1	32,000*	78.3	32,000*	79.4	30,960*
	90	75.3	32,000*	76.4	32,000*	77.5	29,370*
	100	73.4	32,000*	74.6	32,000*	75.7	27,940*
	110	71.5	32,000*	72.7	32,000*	73.8	26,660*
	120	69.6	32,000*	70.8	32,000*	71.8	25,520*
	130	67.7	32,000*	68.9	32,000*	69.9	24,480*
	140	65.8	28,950	66.9	28,950	67.9	23,600*
280' (85.3 m)	150	63.8	25,610	64.9	25,620	65.9	22,670*
	160	61.8	22,730	62.9	22,730	63.9	21,970*
	170	59.7	20,200	60.9	20,210	61.8	20,220
	180	57.6	17,980	58.7	17,990	59.7	18,000
	190	55.5	16,010	56.6	16,020	57.5	16,030
	200	53.3	14,250	54.4	14,250	55.3	14,270
	210	51.0	12,680	52.1	12,680	53.0	12,690
	220	48.7	11,260	49.7	11,260	50.6	11,280
	230	46.2	9,970	47.3	9,980	48.1	9,990
	240	43.7	8,800	44.7	8,800	45.5	8,820
	250	41.0	7,730	42.0	7,740	42.7	7,750
	260	38.2	6,760	39.2	6,770	39.8	6,780
	270	35.1	5,870	36.1	5,880	36.7	5,900
	280	31.9	4,680*	32.8	4,940*	33.3	5,090

4

WITH 92HI OFFSET TIP BOOM, 16HL JIB

195,000 lb + 64,000 lb CB

360°

ANSI B 30.5

40' (12.2 m) Jib length

Boom length	Jib Radius (Feet)	5.0 Deg offset		15.0 Deg offset		25.0 Deg offset	
		Boom Angle	Rating (Pounds)	Boom Angle	Rating (Pounds)	Boom Angle	Rating (Pounds)
	55	81.9	32,000*	-	-	-	-
	60	81.0	32,000*	-	-	-	-
	70	79.3	32,000*	80.4	32,000*	81.5	32,000*
	80	77.5	32,000*	78.6	32,000*	79.7	31,320*
	90	75.7	32,000*	76.9	32,000*	77.9	29,730*
	100	73.9	32,000*	75.1	32,000*	76.1	28,280*
	110	72.1	32,000*	73.2	32,000*	74.3	26,990*
	120	70.3	32,000*	71.4	32,000*	72.4	25,780*
	130	68.4	32,000*	69.6	32,000*	70.6	24,810*
	140	66.6	28,430	67.7	28,430	68.7	23,830*
	150	64.7	25,090	65.8	25,090	66.7	22,970*
	160	62.7	22,200	63.8	22,210	64.8	22,210*
290' (88.4 m)	170	60.7	19,680	61.8	19,680	62.8	19,700
	180	58.7	17,450	59.8	17,450	60.7	17,460
	190	56.7	15,480	57.7	15,480	58.7	15,490
	200	54.6	13,720	55.6	13,730	56.5	13,740
	210	52.4	12,130	53.5	12,140	54.3	12,150
	220	50.2	10,710	51.2	10,720	52.1	10,730
	230	47.9	9,420	48.9	9,430	49.7	9,450
	240	45.5	8,250	46.5	8,260	47.3	8,270
	250	43.0	7,190	44.0	7,200	44.7	7,210
	260	40.3	6,210	41.3	6,220	42.0	6,240
	270	37.6	5,210*	38.5	5,330	39.2	5,350
	280	34.6	4,010*	35.5	4,270*	36.1	4,460*
	290	31.4	2,830*	32.2	3,080*	32.8	3,240*

Boom length	Jib Radius (Feet)	5.0 Deg offset		15.0 Deg offset		25.0 Deg offset	
		Boom Angle	Rating (Pounds)	Boom Angle	Rating (Pounds)	Boom Angle	Rating (Pounds)
	56	82.0	32,000*	-	-	-	-
	60	81.3	32,000*	-	-	-	-
	70	79.6	32,000*	80.7	32,000*	81.8	32,000*
	80	77.9	32,000*	79.0	32,000*	80.0	31,530*
	90	76.1	32,000*	77.3	32,000*	78.3	29,940*
	100	74.4	32,000*	75.5	32,000*	76.5	28,470*
	110	72.7	32,000*	73.8	32,000*	74.8	27,250*
	120	70.9	32,000*	72.0	32,000*	73.0	26,170*
	130	69.1	31,790	70.2	31,790	71.2	25,030*
	140	67.3	27,890	68.4	27,890	69.3	24,090*
	150	65.4	24,540	66.5	24,540	67.5	23,320*
	160	63.6	21,650	64.6	21,660	65.6	21,670
300' (91.4 m)	170	61.7	19,120	62.7	19,130	63.7	19,140
	180	59.8	16,890	60.8	16,900	61.7	16,910
	190	57.8	14,920	58.8	14,930	59.7	14,940
	200	55.8	13,150	56.8	13,160	57.7	13,170
	210	53.7	11,580	54.7	11,580	55.6	11,590
	220	51.6	10,150	52.6	10,160	53.4	10,170
	230	49.4	8,850	50.4	8,860	51.2	8,870
	240	47.1	7,680	48.1	7,690	48.9	7,710
	250	44.8	6,610	45.7	6,620	46.5	6,630
	260	42.3	5,560*	43.3	5,640	44.0	5,650
	270	39.7	4,360*	40.7	4,640*	41.3	4,760
	280	37.0	3,210*	37.9	3,480*	38.5	3,670*

50' (15.2 m) Jib length

Boom length	Jib Radius (Feet)	5.0 Deg offset		15.0 Deg offset		25.0 Deg offset	
		Boom Angle	Rating (Pounds)	Boom Angle	Rating (Pounds)	Boom Angle	Rating (Pounds)
	35	81.8	32,000*	-	-	-	-
	40	80.2	32,000*	-	-	-	-
	50	77.0	31,320*	79.6	28,880*	-	-
	60	73.7	30,180*	76.3	27,950*	78.8	25,020*
130' (39.6 m)	70	70.4	29,140*	73.0	27,200*	75.4	22,960*
	80	66.9	28,190*	69.5	26,560*	71.9	21,180*
	90	63.4	27,440*	66.0	25,820*	68.3	19,660*
	100	59.8	26,620*	62.3	23,700*	64.6	18,410*
	110	56.0	26,010*	58.5	21,930*	60.7	17,400*
	120	52.1	24,520*	54.5	20,470*	56.6	16,470*
	130	47.9	22,710*	50.3	19,200*	52.3	15,710*
	36	81.9	32,000*	-	-	-	-
	40	80.7	32,000*	-	-	-	-
	50	77.7	31,450*	80.2	28,930*	-	-
	60	74.6	30,350*	77.1	28,110*	79.4	25,490*
140' (42.7 m)	70	71.4	29,470*	73.9	27,330*	76.2	23,390*
	80	68.2	28,510*	70.7	26,690*	72.9	21,640*
	90	64.9	27,640*	67.4	26,040*	69.6	20,140*
	100	61.6	26,990*	63.9	24,490*	66.1	18,890*
	110	58.1	26,240*	60.4	22,680*	62.5	17,780*
	120	54.4	25,650*	56.7	21,180*	58.8	16,890*
	130	50.6	23,830*	52.9	19,910*	54.8	16,120*
	140	46.5	22,230*	48.8	18,780*	50.6	15,450*

Boom length	Jib Radius (Feet)	5.0 Deg offset		15.0 Deg offset		25.0 Deg offset	
		Boom Angle	Rating (Pounds)	Boom Angle	Rating (Pounds)	Boom Angle	Rating (Pounds)
	38	81.8	32,000*	-	-	-	-
	40	81.2	32,000*	-	-	-	-
	50	78.3	31,720*	80.7	29,000*	-	-
	60	75.4	30,630*	77.7	28,270*	80.0	25,820*
	70	72.4	29,660*	74.7	27,530*	76.9	23,800*
	80	69.4	28,820*	71.7	26,870*	73.8	22,000*
150' (45.7 m)	90	66.3	27,930*	68.6	26,290*	70.7	20,510*
	100	63.1	27,250*	65.4	25,310*	67.4	19,300*
	110	59.8	26,600*	62.1	23,480*	64.1	18,240*
	120	56.4	26,010*	58.7	21,900*	60.6	17,300*
	130	52.9	24,810*	55.1	20,570*	57.0	16,510*
	140	49.2	23,190*	51.4	19,400*	53.2	15,760*
	150	45.2	21,780*	47.4	18,400*	49.1	15,230*
	39	81.9	32,000*	-	-	-	-
	40	81.6	32,000*	-	-	-	-
	50	78.9	31,880*	81.1	29,090*	-	-
	60	76.1	30,800*	78.3	28,270*	80.5	26,160*
	70	73.2	29,820*	75.5	27,610*	77.6	24,160*
	80	70.4	29,050*	72.6	26,970*	74.7	22,430*
160' (48.8 m)	90	67.5	28,160*	69.7	26,430*	71.7	20,930*
	100	64.5	27,500*	66.7	25,900*	68.6	19,710*
	110	61.4	26,840*	63.6	24,200*	65.5	18,580*
	120	58.2	26,190*	60.4	22,630*	62.3	17,670*
	130	55.0	25,700*	57.1	21,260*	58.9	16,840*
	140	51.5	24,160*	53.6	20,050*	55.4	16,140*
	150	47.9	22,670*	50.0	18,980*	51.7	15,490*
	160	44.1	21,300*	46.1	18,100*	47.7	14,990*

WITH 92HI OFFSET TIP BOOM, 16HL JIB

195,000 lb + 64,000 lb CB

360°

ANSI B 30.5

50' (15.2 m) Jib length

Boom length	Jib Radius (Feet)	5.0 Deg offset		15.0 Deg offset		25.0 Deg offset	
		Boom Angle	Rating (Pounds)	Boom Angle	Rating (Pounds)	Boom Angle	Rating (Pounds)
	40	82.0	32,000*	-	-	-	-
	50	79.4	31,920*	81.5	29,150*	-	-
	60	76.7	30,970*	78.9	28,390*	80.9	26,390*
	70	74.0	30,100*	76.2	27,700*	78.2	24,420*
	80	71.3	29,230*	73.4	27,060*	75.4	22,790*
	90	68.5	28,430*	70.6	26,480*	72.6	21,300*
170' (51.8 m)	100	65.7	27,710*	67.8	26,010*	69.7	20,030*
	110	62.8	27,110*	64.9	24,930*	66.7	18,960*
	120	59.8	26,440*	61.9	23,300*	63.7	17,990*
	130	56.8	25,920*	58.8	21,900*	60.6	17,200*
	140	53.6	25,160*	55.6	20,710*	57.3	16,490*
	150	50.2	23,590*	52.2	19,620*	53.9	15,850*
	160	46.7	22,190*	48.7	18,650*	50.3	15,270*
	170	43.0	21,000*	44.9	17,830*	46.4	14,800*

	42	81.8	32,000*	-	-	-	-
	50	79.8	32,000*	81.9	29,100*	-	-
	60	77.3	31,060*	79.4	28,450*	81.3	26,390*
	70	74.7	30,240*	76.8	27,760*	78.7	24,750*
	80	72.1	29,390*	74.2	27,130*	76.1	23,150*
	90	69.5	28,580*	71.5	26,660*	73.4	21,650*
180' (54.9 m)	100	66.8	27,930*	68.8	26,120*	70.7	20,390*
	110	64.1	27,270*	66.1	25,670*	67.9	19,300*
	120	61.3	26,700*	63.3	23,980*	65.0	18,380*
	130	58.4	26,150*	60.3	22,510*	62.1	17,550*
	140	55.4	25,600*	57.3	21,300*	59.0	16,800*
	150	52.3	24,420*	54.2	20,190*	55.8	16,150*
	160	49.1	22,980*	50.9	19,200*	52.5	15,580*
	170	45.6	21,740*	47.5	18,350*	49.0	15,080*
	180	42.0	20,700*	43.8	17,610*	45.2	14,660*

	43	81.9	32,000*	-	-	-	-
	50	80.3	32,000*	-	-	-	-
	60	77.8	31,130*	79.8	28,510*	81.7	26,360*
	70	75.4	30,280*	77.4	27,860*	79.2	25,130*
	80	72.9	29,550*	74.9	27,230*	76.7	23,410*
	90	70.4	28,840*	72.3	26,730*	74.1	21,980*
190' (57.9 m)	100	67.8	28,150*	69.8	26,210*	71.5	20,720*
	110	65.2	27,510*	67.2	25,790*	68.9	19,640*
	120	62.6	26,880*	64.5	24,580*	66.2	18,720*
	130	59.9	26,300*	61.7	23,160*	63.4	17,830*
	140	57.0	25,890*	58.9	21,860*	60.5	17,100*
	150	54.1	25,320*	56.0	20,710*	57.5	16,410*
	160	51.1	23,860*	52.9	19,750*	54.4	15,870*
	170	48.0	22,550*	49.7	18,860*	51.2	15,330*
	180	44.6	21,370*	46.4	18,070*	47.8	14,890*
	190	41.1	20,380*	42.8	17,380*	44.1	14,540*

Boom length	Jib Radius (Feet)	5.0 Deg offset		15.0 Deg offset		25.0 Deg offset	
		Boom Angle	Rating (Pounds)	Boom Angle	Rating (Pounds)	Boom Angle	Rating (Pounds)
	45	81.8	32,000*	-	-	-	-
	50	80.6	32,000*	-	-	-	-
	60	78.3	31,310*	80.2	28,520*	-	-
	70	76.0	30,430*	77.9	27,950*	79.6	25,400*
	80	73.6	29,640*	75.5	27,320*	77.2	23,740*
	90	71.2	28,940*	73.1	26,770*	74.8	22,270*
	100	68.8	28,280*	70.6	26,380*	72.3	21,100*
	110	66.3	27,700*	68.1	25,870*	69.8	20,010*
200' (61.0 m)	120	63.8	27,040*	65.6	25,240*	67.2	19,010*
	130	61.2	26,570*	63.0	23,730*	64.6	18,130*
	140	58.5	26,100*	60.3	22,430*	61.9	17,410*
	150	55.8	25,620*	57.6	21,240*	59.1	16,730*
	160	53.0	24,640*	54.7	20,290*	56.2	16,160*
	170	50.0	23,340*	51.7	19,380*	53.2	15,600*
	180	46.9	22,100*	48.6	18,530*	50.0	15,150*
	190	43.7	20,350	45.3	17,840*	46.6	14,760*
	200	40.2	18,600	41.8	17,220*	43.0	14,400*

	46	81.9	32,000*	-	-	-	-
	50	81.0	32,000*	-	-	-	-
	60	78.8	31,360*	80.6	28,540*	-	-
	70	76.5	30,590*	78.4	27,920*	80.1	25,680*
	80	74.3	29,860*	76.1	27,450*	77.8	24,000*
	90	72.0	29,110*	73.8	26,880*	75.4	22,570*
	100	69.6	28,410*	71.4	26,440*	73.1	21,320*
	110	67.3	27,840*	69.0	25,970*	70.6	20,270*
210' (64.0 m)	120	64.9	27,250*	66.6	25,580*	68.2	19,290*
	130	62.4	26,690*	64.1	24,290*	65.7	18,480*
	140	59.9	26,230*	61.6	22,980*	63.1	17,690*
	150	57.3	25,750*	59.0	21,790*	60.5	17,030*
	160	54.6	25,390*	56.3	20,780*	57.7	16,420*
	170	51.8	23,950	53.5	19,830*	54.9	15,840*
	180	49.0	21,740	50.6	19,020*	52.0	15,360*
	190	45.9	19,790	47.6	18,270*	48.9	14,940*
	200	42.8	18,040	44.3	17,630*	45.6	14,580*
	210	39.4	16,480	40.9	16,490	42.1	14,290*

	47	82.0	32,000*	-	-	-	-
	50	81.3	32,000*	-	-	-	-
	60	79.2	31,420*	81.0	28,520*	-	-
	70	77.0	30,750*	78.8	27,970*	80.4	25,850*
	80	74.9	29,950*	76.6	27,480*	78.2	24,260*
	90	72.6	29,210*	74.4	26,920*	76.0	22,850*
	100	70.4	28,660*	72.1	26,510*	73.7	21,650*
	110	68.1	27,990*	69.9	26,050*	71.4	20,520*
220' (67.1 m)	120	65.8	27,450*	67.5	25,630*	69.1	19,620*
	130	63.5	26,900*	65.2	24,860*	66.7	18,700*
	140	61.1	26,370*	62.8	23,560*	64.2	17,920*
	150	58.6	26,000*	60.3	22,370*	61.7	17,300*
	160	56.1	25,530*	57.7	21,240*	59.2	16,690*
	170	53.5	23,410	55.1	20,330*	56.5	16,080*
	180	50.8	21,190	52.4	19,430*	53.7	15,620*
	190	48.0	19,220	49.6	18,700*	50.8	15,160*
	200	45.0	17,480	46.6	17,490	47.8	14,800*
	210	41.9	15,910	43.4	15,920	44.6	14,500*
	220	38.6	14,510	40.1	14,520	41.2	14,210*

4

WITH 92HI OFFSET TIP BOOM, 16HL JIB

195,000 lb + 64,000 lb CB

360°

ANSI B 30.5

50' (15.2 m) Jib length

Boom length	Jib Radius (Feet)	5.0 Deg offset Boom Angle	5.0 Deg offset Rating (Pounds)	15.0 Deg offset Boom Angle	15.0 Deg offset Rating (Pounds)	25.0 Deg offset Boom Angle	25.0 Deg offset Rating (Pounds)
	49	81.9	32,000*	-	-	-	-
	50	81.7	32,000*	-	-	-	-
	60	79.6	31,420*	81.3	28,460*	-	-
	70	77.5	30,750*	79.2	28,040*	80.8	25,860*
	80	75.4	30,010*	77.1	27,490*	78.7	24,490*
	90	73.3	29,290*	75.0	27,050*	76.5	23,100*
	100	71.1	28,680*	72.8	26,550*	74.3	21,880*
	110	69.0	28,150*	70.6	26,140*	72.1	20,850*
230' (70.1 m)	120	66.8	27,530*	68.4	25,750*	69.9	19,840*
	130	64.5	27,030*	66.1	25,340*	67.6	19,000*
	140	62.2	26,560*	63.8	24,060*	65.3	18,260*
	150	59.9	26,100*	61.5	22,870*	62.9	17,510*
	160	57.5	25,570	59.1	21,790*	60.4	16,940*
	170	55.0	23,070	56.6	20,810*	57.9	16,320*
	180	52.5	20,850	54.0	19,930*	55.3	15,820*
	190	49.8	18,890	51.3	18,900	52.6	15,380*
	200	47.1	17,130	48.6	17,140	49.8	15,010*
	210	44.2	15,570	45.7	15,580	46.8	14,650*
	220	41.1	14,160	42.6	14,170	43.7	14,190
	230	37.9	12,880	39.3	12,890	40.3	12,910

	50	81.9	32,000*	-	-	-	-
	60	79.9	31,500*	81.6	28,480*	-	-
	70	77.9	30,750*	79.6	28,030*	81.1	25,920*
	80	75.9	30,090*	77.5	27,510*	79.1	24,770*
	90	73.9	29,380*	75.5	27,080*	77.0	23,350*
	100	71.8	28,790*	73.4	26,580*	74.9	22,200*
	110	69.7	28,270*	71.3	26,200*	72.8	21,130*
	120	67.6	27,660*	69.2	25,820*	70.6	20,100*
240' (73.2 m)	130	65.4	27,230*	67.0	25,410*	68.4	19,260*
	140	63.3	26,730*	64.8	24,580*	66.2	18,470*
	150	61.0	26,220*	62.6	23,360*	63.9	17,790*
	160	58.7	25,050	60.3	22,300*	61.6	17,170*
	170	56.4	22,530	57.9	21,290*	59.2	16,560*
	180	54.0	20,310	55.5	20,320	56.8	16,050*
	190	51.5	18,350	53.0	18,360	54.2	15,600*
	200	48.9	16,600	50.4	16,610	51.6	15,230*
	210	46.2	15,020	47.6	15,030	48.8	14,840*
	220	43.4	13,610	44.8	13,620	45.9	13,640
	230	40.4	12,340	41.8	12,350	42.8	12,360
	240	37.2	11,180	38.5	11,190	39.5	11,210

	52	81.8	32,000*	-	-	-	-
	60	80.3	31,550*	81.9	28,510*	-	-
	70	78.3	30,930*	79.9	28,010*	81.4	25,860*
	80	76.4	30,140*	78.0	27,530*	79.4	25,010*
	90	74.4	29,570*	76.0	27,090*	77.5	23,660*
	100	72.4	28,990*	74.0	26,720*	75.4	22,400*
	110	70.4	28,370*	72.0	26,230*	73.4	21,340*
	120	68.4	27,810*	69.9	25,860*	71.3	20,400*
	130	66.3	27,330*	67.8	25,560*	69.2	19,510*
	140	64.2	26,900*	65.7	25,070*	67.1	18,700*
250' (76.2 m)	150	62.1	26,420*	63.6	23,860*	64.9	18,050*
	160	59.9	24,480	61.4	22,750*	62.7	17,400*
	170	57.6	21,960	59.1	21,710*	60.4	16,790*
	180	55.3	19,750	56.8	19,750	58.1	16,340*
	190	53.0	17,780	54.4	17,790	55.7	15,820*
	200	50.5	16,030	52.0	16,040	53.2	15,430*
	210	48.0	14,450	49.4	14,460	50.6	14,470
	220	45.4	13,040	46.7	13,040	47.8	13,060
	230	42.6	11,760	43.9	11,760	45.0	11,780
	240	39.6	10,590	41.0	10,600	42.0	10,620
	250	36.5	9,530	37.8	9,540	38.7	9,560

Boom length	Jib Radius (Feet)	5.0 Deg offset Boom Angle	5.0 Deg offset Rating (Pounds)	15.0 Deg offset Boom Angle	15.0 Deg offset Rating (Pounds)	25.0 Deg offset Boom Angle	25.0 Deg offset Rating (Pounds)
	53	81.9	32,000*	-	-	-	-
	60	80.6	31,550*	-	-	-	-
	70	78.7	30,900*	80.3	27,990*	81.7	25,870*
	80	76.8	30,200*	78.4	27,560*	79.8	25,250*
	90	74.9	29,650*	76.5	27,100*	77.9	23,870*
	100	73.0	28,990*	74.5	26,750*	75.9	22,670*
	110	71.1	28,450*	72.6	26,260*	74.0	21,570*
	120	69.1	27,890*	70.6	25,880*	72.0	20,630*
	130	67.1	27,430*	68.6	25,520*	69.9	19,800*
	140	65.1	27,030*	66.6	25,210*	67.9	18,990*
260' (79.2 m)	150	63.0	26,560*	64.5	24,390*	65.8	18,250*
	160	61.0	23,940	62.4	23,180*	63.7	17,610*
	170	58.8	21,420	60.3	21,420	61.5	17,080*
	180	56.6	19,200	58.0	19,210	59.3	16,490*
	190	54.4	17,230	55.8	17,240	57.0	16,030*
	200	52.0	15,480	53.4	15,490	54.6	15,500
	210	49.7	13,900	51.0	13,900	52.2	13,920
	220	47.2	12,480	48.5	12,490	49.6	12,500
	230	44.6	11,200	45.9	11,200	47.0	11,220
	240	41.8	10,030	43.2	10,040	44.2	10,050
	250	39.0	8,960	40.3	8,970	41.2	8,990
	260	35.9	8,000	37.1	8,010	38.0	8,030

	54	82.0	31,970*	-	-	-	-
	60	80.9	31,620*	-	-	-	-
	70	79.1	30,990*	80.6	27,980*	82.0	25,820*
	80	77.3	30,250*	78.7	27,580*	80.1	25,450*
	90	75.4	29,720*	76.9	27,100*	78.3	24,060*
	100	73.6	29,040*	75.0	26,760*	76.4	22,860*
	110	71.7	28,490*	73.2	26,290*	74.5	21,850*
	120	69.8	28,060*	71.2	25,990*	72.6	20,820*
	130	67.9	27,560*	69.3	25,640*	70.6	20,010*
	140	65.9	27,070*	67.4	25,270*	68.6	19,230*
270' (82.3 m)	150	64.0	26,290	65.4	24,770*	66.6	18,490*
	160	61.9	23,410	63.4	23,410	64.6	17,830*
	170	59.9	20,870	61.3	20,880	62.5	17,250*
	180	57.8	18,650	59.2	18,660	60.4	16,710*
	190	55.6	16,680	57.0	16,690	58.2	16,250*
	200	53.4	14,930	54.8	14,940	55.9	14,950
	210	51.2	13,350	52.5	13,350	53.6	13,370
	220	48.8	11,930	50.1	11,930	51.2	11,950
	230	46.4	10,640	47.7	10,650	48.7	10,660
	240	43.8	9,470	45.1	9,480	46.1	9,490
	250	41.2	8,400	42.4	8,410	43.4	8,430
	260	38.3	7,430	39.6	7,440	40.4	7,460
	270	35.3	6,540	36.5	6,550	37.3	6,570

WITH 92HI OFFSET TIP BOOM, 16HL JIB

195,000 lb + 64,000 lb CB

360°

ANSI B 30.5

50' (15.2 m) Jib length

Boom length	Jib Radius (Feet)	5.0 Deg offset		15.0 Deg offset		25.0 Deg offset	
		Boom Angle	Rating (Pounds)	Boom Angle	Rating (Pounds)	Boom Angle	Rating (Pounds)
	56	81.9	31,660*	-	-	-	-
	60	81.2	31,490*	-	-	-	-
	70	79.4	30,900*	80.9	27,920*	-	-
	80	77.7	30,240*	79.1	27,470*	80.4	25,370*
	90	75.9	29,630*	77.3	27,080*	78.6	24,320*
	100	74.1	29,080*	75.5	26,650*	76.8	23,150*
	110	72.3	28,540*	73.7	26,300*	75.0	22,050*
	120	70.4	28,010*	71.8	25,890*	73.1	21,120*
	130	68.6	27,510*	70.0	25,550*	71.3	20,180*
	140	66.7	27,090*	68.1	25,310*	69.3	19,470*
280' (85.3 m)	150	64.8	25,920	66.2	24,960*	67.4	18,750*
	160	62.9	23,030	64.2	23,040	65.5	18,070*
	170	60.9	20,510	62.3	20,520	63.4	17,460*
	180	58.9	18,290	60.2	18,290	61.4	16,920*
	190	56.8	16,320	58.2	16,320	59.3	16,340
	200	54.7	14,560	56.0	14,570	57.2	14,580
	210	52.6	12,980	53.9	12,980	55.0	13,000
	220	50.3	11,550	51.6	11,560	52.7	11,580
	230	48.0	10,260	49.3	10,270	50.3	10,290
	240	45.6	9,090	46.9	9,100	47.9	9,120
	250	43.1	8,030	44.4	8,040	45.3	8,060
	260	40.5	7,050	41.7	7,060	42.6	7,080
	270	37.7	6,160	38.9	6,170	39.7	6,190
	280	34.7	5,230*	35.9	5,360	36.7	5,380

	57	81.9	31,620*	-	-	-	-
	60	81.4	31,390*	-	-	-	-
	70	79.7	30,860*	81.1	27,830*	-	-
	80	78.0	30,160*	79.4	27,420*	80.7	25,250*
	90	76.3	29,590*	77.7	27,070*	79.0	24,510*
	100	74.6	29,120*	75.9	26,650*	77.2	23,320*
	110	72.8	28,570*	74.2	26,280*	75.4	22,250*
	120	71.0	28,030*	72.4	25,980*	73.7	21,260*
	130	69.2	27,550*	70.6	25,530*	71.8	20,470*
	140	67.4	27,100*	68.8	25,280*	70.0	19,640*
	150	65.6	25,400	66.9	24,930*	68.1	18,920*
	160	63.7	22,510	65.1	22,520	66.2	18,290*
290' (88.4 m)	170	61.8	19,990	63.2	19,990	64.3	17,670*
	180	59.9	17,750	61.2	17,760	62.4	17,160*
	190	57.9	15,780	59.2	15,790	60.4	15,800
	200	55.9	14,020	57.2	14,030	58.3	14,040
	210	53.8	12,440	55.1	12,440	56.2	12,460
	220	51.7	11,010	53.0	11,020	54.0	11,040
	230	49.5	9,720	50.8	9,730	51.8	9,750
	240	47.3	8,550	48.5	8,560	49.5	8,580
	250	44.9	7,480	46.1	7,490	47.1	7,510
	260	42.4	6,500	43.6	6,510	44.6	6,530
	270	39.9	5,610	41.0	5,620	41.9	5,640
	280	37.1	4,480*	38.3	4,800	39.1	4,820
	290	34.2	3,360*	35.3	3,670*	36.0	3,890*

Boom length	Jib Radius (Feet)	5.0 Deg offset		15.0 Deg offset		25.0 Deg offset	
		Boom Angle	Rating (Pounds)	Boom Angle	Rating (Pounds)	Boom Angle	Rating (Pounds)
	59	81.8	31,440*	-	-	-	-
	60	81.7	31,440*	-	-	-	-
	70	80.0	30,790*	81.4	27,880*	-	-
	80	78.4	30,320*	79.7	27,430*	81.0	25,220*
	90	76.7	29,690*	78.0	27,070*	79.3	24,680*
	100	75.0	29,120*	76.4	26,730*	77.6	23,480*
	110	73.3	28,710*	74.6	26,340*	75.9	22,480*
	120	71.6	28,190*	72.9	25,910*	74.1	21,500*
	130	69.9	27,730*	71.2	25,590*	72.4	20,620*
	140	68.1	27,280*	69.4	25,320*	70.6	19,860*
	150	66.3	24,850	67.6	24,850	68.8	19,180*
	160	64.5	21,960	65.8	21,960	67.0	18,500*
300' (91.4 m)	170	62.7	19,430	64.0	19,440	65.1	17,930*
	180	60.8	17,200	62.1	17,200	63.2	17,220
	190	58.9	15,230	60.2	15,230	61.3	15,250
	200	57.0	13,460	58.3	13,460	59.4	13,480
	210	55.0	11,880	56.3	11,890	57.3	11,900
	220	53.0	10,450	54.2	10,460	55.3	10,480
	230	50.9	9,160	52.1	9,170	53.2	9,180
	240	48.8	7,980	50.0	7,990	51.0	8,010
	250	46.5	6,900	47.7	6,910	48.7	6,930
	260	44.2	5,910*	45.4	5,940	46.3	5,960
	270	41.8	4,750*	43.0	5,040	43.8	5,060
	280	39.3	3,630*	40.4	3,970*	41.2	4,220*
	290	36.6	2,570*	37.7	2,890*	38.4	3,120*

WITH 92HI OFFSET TIP BOOM, 16HL JIB

195,000 lb + 64,000 lb CB

360°

ANSI B 30.5

60' (18.3 m) Jib length

Boom length	Jib Radius (Feet)	5.0 Deg offset		15.0 Deg offset		25.0 Deg offset	
		Boom Angle	Rating (Pounds)	Boom Angle	Rating (Pounds)	Boom Angle	Rating (Pounds)
	40	81.8	30,030*	-	-	-	-
	50	79.1	28,950*	81.8	26,180*	-	-
	60	76.3	27,870*	79.0	25,360*	81.6	22,670*
	70	73.5	26,880*	76.2	24,650*	78.7	20,790*
150' (45.7 m)	80	70.6	25,950*	73.3	24,000*	75.8	19,280*
	90	67.7	25,120*	70.4	23,320*	72.8	17,970*
	100	64.7	24,360*	67.3	22,130*	69.8	16,830*
	110	61.6	23,680*	64.2	20,490*	66.6	15,840*
	120	58.5	23,060*	61.1	19,080*	63.4	15,030*
	130	55.2	21,770*	57.7	17,920*	60.0	14,290*
	140	51.8	20,300*	54.3	16,860*	56.4	13,670*
	150	48.1	19,030*	50.6	15,990*	52.7	13,120*

	41	82.0	30,100*	-	-	-	-
	50	79.6	29,040*	-	-	-	-
	60	76.9	27,960*	79.5	25,480*	82.0	22,840*
	70	74.3	27,100*	76.8	24,710*	79.3	21,050*
	80	71.5	26,150*	74.1	24,050*	76.5	19,550*
	90	68.8	25,410*	71.3	23,490*	73.7	18,280*
160' (48.8 m)	100	65.9	24,630*	68.5	22,760*	70.8	17,160*
	110	63.0	23,910*	65.5	21,040*	67.8	16,160*
	120	60.1	23,340*	62.5	19,690*	64.8	15,350*
	130	57.0	22,620*	59.4	18,470*	61.6	14,590*
	140	53.8	21,100*	56.2	17,420*	58.3	13,930*
	150	50.5	19,730*	52.9	16,460*	54.9	13,370*
	160	47.0	18,600*	49.3	15,670*	51.3	12,920*

	43	81.8	29,870*	-	-	-	-
	50	80.0	29,150*	-	-	-	-
	60	77.5	28,190*	80.0	25,510*	-	-
	70	75.0	27,200*	77.4	24,870*	79.8	21,340*
	80	72.4	26,360*	74.8	24,190*	77.1	19,850*
	90	69.7	25,550*	72.2	23,560*	74.4	18,510*
170' (51.8 m)	100	67.0	24,870*	69.5	23,060*	71.7	17,410*
	110	64.3	24,190*	66.7	21,630*	68.9	16,440*
	120	61.5	23,520*	63.9	20,230*	66.0	15,590*
	130	58.6	23,020*	61.0	19,010*	63.0	14,900*
	140	55.6	21,950*	57.9	17,920*	60.0	14,210*
	150	52.5	20,520*	54.8	16,930*	56.8	13,670*
	160	49.3	19,280*	51.5	16,110*	53.4	13,150*
	170	45.9	18,220*	48.1	15,360*	49.9	12,700*

	44	81.9	29,770*	-	-	-	-
	50	80.5	29,210*	-	-	-	-
	60	78.0	28,160*	80.4	25,490*	-	-
	70	75.6	27,270*	78.0	24,890*	80.2	21,580*
	80	73.1	26,450*	75.5	24,310*	77.7	20,130*
	90	70.6	25,720*	72.9	23,710*	75.1	18,800*
180' (54.9 m)	100	68.1	25,010*	70.4	23,190*	72.5	17,680*
	110	65.5	24,340*	67.8	22,220*	69.9	16,710*
	120	62.8	23,770*	65.1	20,760*	67.1	15,880*
	130	60.1	23,170*	62.3	19,470*	64.3	15,140*
	140	57.2	22,710*	59.5	18,420*	61.5	14,480*
	150	54.3	21,240*	56.6	17,400*	58.5	13,920*
	160	51.3	19,970*	53.5	16,550*	55.4	13,380*
	170	48.2	18,880*	50.3	15,790*	52.1	12,920*
	180	44.8	17,910*	46.9	15,150*	48.7	12,530*

Boom length	Jib Radius (Feet)	5.0 Deg offset		15.0 Deg offset		25.0 Deg offset	
		Boom Angle	Rating (Pounds)	Boom Angle	Rating (Pounds)	Boom Angle	Rating (Pounds)
	45	82.0	29,710*	-	-	-	-
	50	80.8	29,210*	-	-	-	-
	60	78.5	28,290*	80.8	25,540*	-	-
	70	76.2	27,490*	78.5	24,940*	80.6	21,800*
	80	73.8	26,660*	76.1	24,350*	78.2	20,350*
	90	71.4	25,900*	73.7	23,770*	75.8	19,060*
190' (57.9 m)	100	69.0	25,230*	71.2	23,250*	73.3	17,920*
	110	66.5	24,580*	68.7	22,760*	70.7	16,970*
	120	64.0	23,950*	66.2	21,310*	68.2	16,120*
	130	61.4	23,410*	63.6	20,020*	65.5	15,390*
	140	58.7	22,870*	60.9	18,830*	62.8	14,750*
	150	56.0	22,030*	58.1	17,850*	60.0	14,150*
	160	53.1	20,690*	55.3	17,020*	57.1	13,650*
	170	50.2	19,520*	52.3	16,240*	54.0	13,160*
	180	47.1	18,550*	49.2	15,530*	50.9	12,750*
	190	43.9	17,640*	45.9	14,930*	47.5	12,400*

	47	81.9	29,610*	-	-	-	-
	50	81.2	29,340*	-	-	-	-
	60	79.0	28,400*	81.2	25,630*	-	-
	70	76.7	27,580*	78.9	24,990*	81.0	22,020*
	80	74.4	26,870*	76.6	24,380*	78.7	20,570*
	90	72.2	26,060*	74.3	23,910*	76.3	19,270*
	100	69.8	25,380*	72.0	23,380*	74.0	18,220*
	110	67.5	24,810*	69.6	22,900*	71.5	17,260*
200' (61.0 m)	120	65.0	24,210*	67.2	21,740*	69.1	16,370*
	130	62.6	23,600*	64.7	20,510*	66.6	15,670*
	140	60.1	23,100*	62.1	19,340*	64.0	14,970*
	150	57.5	22,600*	59.5	18,310*	61.3	14,390*
	160	54.8	21,440*	56.8	17,430*	58.6	13,840*
	170	52.0	20,240*	54.0	16,630*	55.8	13,390*
	180	49.1	19,140*	51.1	15,940*	52.8	12,950*
	190	46.1	18,260*	48.1	15,280*	49.7	12,580*
	200	42.9	17,400*	44.9	14,720*	46.4	12,300*

	48	82.0	29,500*	-	-	-	-
	50	81.5	29,340*	-	-	-	-
	60	79.4	28,510*	81.5	25,620*	-	-
	70	77.2	27,670*	79.3	25,030*	81.3	22,180*
	80	75.0	26,950*	77.1	24,420*	79.1	20,730*
	90	72.8	26,170*	74.9	23,920*	76.9	19,530*
	100	70.6	25,550*	72.7	23,500*	74.6	18,450*
	110	68.3	24,900*	70.4	22,980*	72.3	17,450*
210' (64.0 m)	120	66.0	24,340*	68.1	22,290*	69.9	16,640*
	130	63.7	23,830*	65.7	20,990*	67.5	15,870*
	140	61.3	23,340*	63.3	19,770*	65.1	15,180*
	150	58.8	22,830*	60.8	18,750*	62.6	14,610*
	160	56.3	22,070*	58.3	17,870*	60.0	14,070*
	170	53.7	20,860*	55.6	17,010*	57.3	13,590*
	180	51.0	19,790*	52.9	16,330*	54.5	13,170*
	190	48.2	18,770*	50.1	15,640*	51.6	12,790*
	200	45.2	17,900*	47.1	15,060*	48.6	12,450*
	210	42.1	16,770*	43.9	14,550*	45.4	12,170*

WITH 92HI OFFSET TIP BOOM, 16HL JIB

195,000 lb + 64,000 lb CB

360°

ANSI B 30.5

60' (18.3 m) Jib length

Boom length	Jib Radius (Feet)	5.0 Deg offset		15.0 Deg offset		25.0 Deg offset	
		Boom Angle	Rating (Pounds)	Boom Angle	Rating (Pounds)	Boom Angle	Rating (Pounds)
	50	81.8	29,370*	-	-	-	-
	60	79.8	28,600*	81.8	25,610*	-	-
	70	77.7	27,760*	79.7	25,090*	81.6	22,330*
	80	75.6	27,080*	77.6	24,560*	79.5	20,940*
	90	73.5	26,330*	75.5	24,050*	77.4	19,750*
	100	71.3	25,710*	73.3	23,500*	75.2	18,630*
	110	69.1	25,090*	71.1	23,090*	73.0	17,690*
	120	66.9	24,550*	68.9	22,630*	70.7	16,870*
220' (67.1 m)	130	64.7	23,970*	66.7	21,430*	68.4	16,100*
	140	62.4	23,420*	64.3	20,220*	66.1	15,410*
	150	60.1	22,950*	62.0	19,180*	63.7	14,850*
	160	57.6	22,580*	59.6	18,280*	61.2	14,260*
	170	55.2	21,460*	57.1	17,430*	58.7	13,800*
	180	52.6	20,380*	54.5	16,690*	56.1	13,350*
	190	50.0	19,380*	51.8	15,990*	53.4	12,950*
	200	47.2	17,780	49.1	15,410*	50.6	12,600*
	210	44.3	16,210	46.1	14,890*	47.6	12,310*
	220	41.3	14,800	43.0	14,400*	44.4	12,040*

	51	81.9	29,250*	-	-	-	-
	60	80.1	28,490*	-	-	-	-
	70	78.1	27,810*	80.1	25,000*	81.9	22,520*
	80	76.1	27,090*	78.1	24,460*	79.9	21,120*
	90	74.0	26,460*	76.0	24,010*	77.8	19,940*
	100	72.0	25,760*	73.9	23,590*	75.7	18,840*
	110	69.9	25,180*	71.8	23,110*	73.6	17,920*
	120	67.8	24,580*	69.7	22,700*	71.4	17,080*
230' (70.1 m)	130	65.6	24,050*	67.5	21,820*	69.2	16,340*
	140	63.4	23,600*	65.3	20,680*	67.0	15,610*
	150	61.2	23,140*	63.1	19,560*	64.7	15,000*
	160	58.9	22,700*	60.8	18,640*	62.4	14,450*
	170	56.5	22,130*	58.4	17,810*	60.0	13,970*
	180	54.1	21,000*	56.0	17,010*	57.5	13,560*
	190	51.6	19,180	53.4	16,350*	55.0	13,120*
	200	49.0	17,430	50.8	15,760*	52.3	12,760*
	210	46.3	15,860	48.1	15,170*	49.5	12,470*
	220	43.5	14,440	45.2	14,450	46.6	12,190*
	230	40.5	13,170	42.2	13,180	43.5	11,970*

	52	82.0	29,120*	-	-	-	-
	60	80.4	28,510*	-	-	-	-
	70	78.5	27,780*	80.4	24,980*	-	-
	80	76.6	27,120*	78.5	24,490*	80.2	21,330*
	90	74.6	26,490*	76.5	24,010*	78.2	20,080*
	100	72.6	25,920*	74.5	23,580*	76.2	19,070*
	110	70.6	25,240*	72.5	23,210*	74.2	18,130*
	120	68.6	24,700*	70.4	22,730*	72.1	17,290*
240' (73.2 m)	130	66.5	24,260*	68.3	22,300*	70.0	16,530*
	140	64.4	23,730*	66.2	21,070*	67.9	15,860*
	150	62.2	23,300*	64.1	20,030*	65.7	15,250*
	160	60.0	22,860*	61.9	19,040*	63.4	14,670*
	170	57.8	22,470*	59.6	18,140*	61.2	14,200*
	180	55.5	20,610	57.3	17,380*	58.8	13,710*
	190	53.1	18,640	54.9	16,700*	56.4	13,290*
	200	50.7	16,890	52.4	16,050*	53.9	12,920*
	210	48.2	15,320	49.9	15,330	51.3	12,630*
	220	45.5	13,910	47.2	13,910	48.6	12,350*
	230	42.7	12,630	44.4	12,640	45.7	12,070*
	240	39.8	11,460	41.4	11,470	42.6	11,490

Boom length	Jib Radius (Feet)	5.0 Deg offset		15.0 Deg offset		25.0 Deg offset	
		Boom Angle	Rating (Pounds)	Boom Angle	Rating (Pounds)	Boom Angle	Rating (Pounds)
	54	81.9	29,020*	-	-	-	-
	60	80.8	28,640*	-	-	-	-
	70	78.9	27,980*	80.7	25,040*	-	-
	80	77.0	27,240*	78.8	24,530*	80.6	21,440*
	90	75.1	26,610*	76.9	24,100*	78.6	20,320*
	100	73.2	26,030*	75.0	23,650*	76.7	19,270*
	110	71.2	25,480*	73.0	23,300*	74.7	18,300*
	120	69.3	24,840*	71.1	22,830*	72.7	17,450*
	130	67.3	24,380*	69.1	22,440*	70.7	16,710*
	140	65.3	23,930*	67.0	21,480*	68.6	16,070*
250' (76.2 m)	150	63.2	23,480*	65.0	20,450*	66.5	15,400*
	160	61.1	22,960*	62.9	19,440*	64.4	14,840*
	170	59.0	22,260	60.7	18,580*	62.2	14,360*
	180	56.8	20,040	58.5	17,740*	60.0	13,900*
	190	54.5	18,070	56.2	17,050*	57.7	13,460*
	200	52.2	16,320	53.9	16,330	55.3	13,100*
	210	49.8	14,750	51.5	14,760	52.9	12,790*
	220	47.3	13,320	49.0	13,330	50.3	12,500*
	230	44.7	12,040	46.3	12,050	47.6	12,070
	240	42.0	10,880	43.6	10,890	44.8	10,910
	250	39.1	9,810	40.7	9,830	41.8	9,850

	55	82.0	28,970*	-	-	-	-
	60	81.0	28,640*	-	-	-	-
	70	79.2	27,940*	81.0	24,990*	-	-
	80	77.4	27,360*	79.2	24,570*	80.9	21,650*
	90	75.6	26,720*	77.3	24,080*	79.0	20,430*
	100	73.7	26,060*	75.5	23,730*	77.1	19,470*
	110	71.8	25,510*	73.6	23,290*	75.2	18,470*
	120	70.0	24,980*	71.7	22,880*	73.3	17,630*
	130	68.0	24,520*	69.8	22,540*	71.3	16,920*
	140	66.1	24,000*	67.8	21,850*	69.4	16,260*
260' (79.2 m)	150	64.1	23,530*	65.8	20,830*	67.4	15,620*
	160	62.1	23,090*	63.8	19,810*	65.3	15,040*
	170	60.0	21,720	61.7	18,920*	63.2	14,510*
	180	57.9	19,500	59.6	18,100*	61.1	14,070*
	190	55.8	17,530	57.5	17,410*	58.9	13,630*
	200	53.6	15,770	55.2	15,780	56.6	13,260*
	210	51.3	14,200	52.9	14,200	54.3	12,900*
	220	49.0	12,780	50.6	12,790	51.9	12,600*
	230	46.5	11,490	48.1	11,500	49.4	11,520
	240	44.0	10,320	45.5	10,330	46.8	10,350
	250	41.3	9,250	42.8	9,260	44.0	9,280
	260	38.5	8,290	40.0	8,300	41.1	8,320

4

WITH 92HI OFFSET TIP BOOM, 16HL JIB

195,000 lb + 64,000 lb CB

360°

ANSI B 30.5

60' (18.3 m) Jib length

Boom length	Jib Radius (Feet)	5.0 Deg offset		15.0 Deg offset		25.0 Deg offset	
		Boom Angle	Rating (Pounds)	Boom Angle	Rating (Pounds)	Boom Angle	Rating (Pounds)
	57	81.8	28,790*	-	-	-	-
	60	81.3	28,660*	-	-	-	-
	70	79.6	28,010*	81.3	25,050*	-	-
	80	77.8	27,350*	79.5	24,580*	81.2	21,760*
	90	76.0	26,720*	77.7	24,160*	79.4	20,640*
	100	74.2	26,180*	75.9	23,690*	77.5	19,630*
	110	72.4	25,550*	74.1	23,360*	75.7	18,710*
	120	70.6	25,080*	72.3	22,950*	73.8	17,820*
	130	68.7	24,530*	70.4	22,610*	72.0	17,090*
	140	66.9	24,120*	68.5	22,270*	70.0	16,370*
270' (82.3 m)	150	65.0	23,700*	66.6	21,160*	68.1	15,810*
	160	63.0	23,240*	64.7	20,130*	66.1	15,210*
	170	61.0	21,180	62.7	19,280*	64.1	14,680*
	180	59.0	18,960	60.7	18,470*	62.1	14,230*
	190	57.0	16,980	58.6	16,990	60.0	13,820*
	200	54.9	15,220	56.5	15,230	57.8	13,440*
	210	52.7	13,650	54.3	13,650	55.6	13,070*
	220	50.5	12,210	52.0	12,220	53.3	12,240
	230	48.2	10,930	49.7	10,930	51.0	10,950
	240	45.8	9,760	47.3	9,770	48.5	9,790
	250	43.3	8,690	44.8	8,700	45.9	8,720
	260	40.6	7,710	42.1	7,720	43.2	7,750
	270	37.9	6,820	39.3	6,830	40.3	6,860

	58	81.9	28,640*	-	-	-	-
	60	81.6	28,480*	-	-	-	-
	70	79.9	27,810*	81.6	24,900*	-	-
	80	78.2	27,230*	79.8	24,450*	81.4	21,920*
	90	76.4	26,690*	78.1	24,100*	79.7	20,750*
	100	74.7	26,070*	76.4	23,630*	77.9	19,770*
	110	72.9	25,550*	74.6	23,260*	76.1	18,860*
	120	71.2	25,090*	72.8	22,930*	74.3	17,980*
	130	69.4	24,590*	71.0	22,600*	72.5	17,270*
	140	67.6	24,140*	69.2	22,190*	70.7	16,560*
280' (85.3 m)	150	65.7	23,670*	67.4	21,510*	68.8	16,000*
	160	63.9	23,280*	65.5	20,490*	66.9	15,370*
	170	62.0	20,810	63.6	19,650*	65.0	14,910*
	180	60.0	18,580	61.6	18,590	63.0	14,430*
	190	58.1	16,610	59.6	16,620	61.0	13,990*
	200	56.1	14,840	57.6	14,850	59.0	13,610*
	210	54.0	13,270	55.5	13,280	56.8	13,240*
	220	51.9	11,840	53.4	11,850	54.7	11,870
	230	49.7	10,550	51.2	10,560	52.4	10,580
	240	47.4	9,370	48.9	9,380	50.1	9,400
	250	45.0	8,310	46.5	8,320	47.7	8,340
	260	42.6	7,330	44.0	7,340	45.2	7,360
	270	40.0	6,440	41.4	6,450	42.5	6,470
	280	37.3	5,620	38.7	5,630	39.6	5,650

Boom length	Jib Radius (Feet)	5.0 Deg offset		15.0 Deg offset		25.0 Deg offset	
		Boom Angle	Rating (Pounds)	Boom Angle	Rating (Pounds)	Boom Angle	Rating (Pounds)
	59	82.0	28,420*	-	-	-	-
	60	81.8	28,400*	-	-	-	-
	70	80.2	27,820*	81.8	24,850*	-	-
	80	78.5	27,260*	80.1	24,460*	81.7	22,010*
	90	76.8	26,670*	78.5	24,010*	80.0	20,910*
	100	75.1	26,170*	76.8	23,690*	78.3	19,920*
	110	73.4	25,640*	75.1	23,230*	76.6	19,040*
	120	71.7	25,060*	73.3	22,890*	74.8	18,210*
	130	70.0	24,660*	71.6	22,550*	73.1	17,420*
	140	68.2	24,150*	69.8	22,200*	71.3	16,770*
	150	66.5	23,750*	68.1	21,870*	69.5	16,090*
	160	64.7	22,800	66.2	20,840*	67.6	15,590*
290' (88.4 m)	170	62.8	20,270	64.4	19,980*	65.8	15,050*
	180	61.0	18,050	62.5	18,060	63.9	14,600*
	190	59.1	16,080	60.6	16,080	62.0	14,150*
	200	57.2	14,320	58.7	14,320	60.0	13,740*
	210	55.2	12,730	56.7	12,740	58.0	12,750
	220	53.1	11,300	54.6	11,310	55.9	11,330
	230	51.1	10,010	52.5	10,020	53.8	10,040
	240	48.9	8,840	50.4	8,850	51.6	8,870
	250	46.7	7,760	48.1	7,770	49.3	7,790
	260	44.4	6,780	45.8	6,790	46.9	6,810
	270	41.9	5,890	43.3	5,900	44.4	5,930
	280	39.4	4,900*	40.8	5,070	41.8	5,090
	290	36.7	3,820*	38.0	4,190*	39.0	4,350

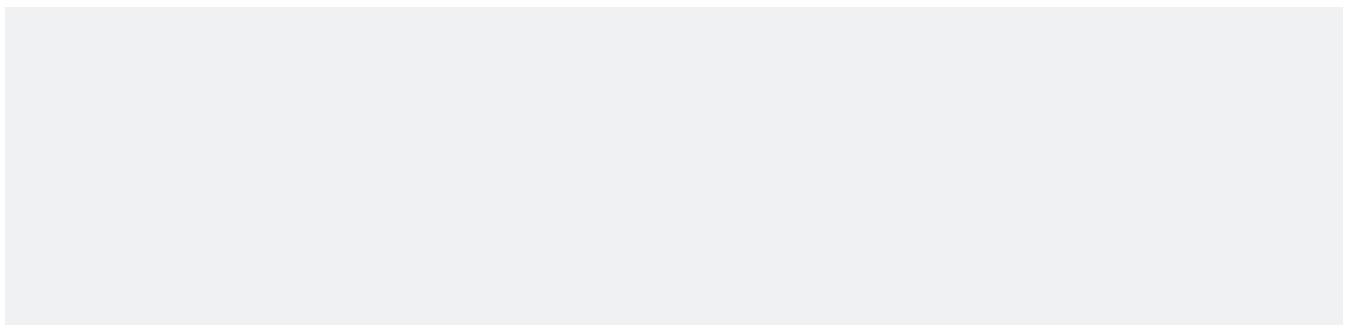

WITH 92HI OFFSET TIP BOOM, 16HL JIB

195,000 lb + 64,000 lb CB

360°

ANSI B 30.5

70' (21.3 m) Jib length

Boom length	Jib Radius (Feet)	5.0 Deg offset		15.0 Deg offset		25.0 Deg offset	
		Boom Angle	Rating (Pounds)	Boom Angle	Rating (Pounds)	Boom Angle	Rating (Pounds)
	46	82.0	22,290*	-	-	-	-
	50	81.0	21,900*	-	-	-	-
	60	78.7	21,140*	81.4	18,910*	-	-
	70	76.4	20,340*	79.0	18,320*	81.6	16,670*
	80	74.0	19,640*	76.7	17,790*	79.2	16,300*
	90	71.6	19,050*	74.2	17,290*	76.7	15,820*
180' (54.9 m)	100	69.2	18,450*	71.8	16,840*	74.2	15,430*
	110	66.7	17,890*	69.3	16,430*	71.7	14,570*
	120	64.2	17,410*	66.7	15,920*	69.1	13,830*
	130	61.6	16,930*	64.1	15,450*	66.4	13,170*
	140	58.9	16,440*	61.5	15,070*	63.7	12,590*
	150	56.2	15,870*	58.7	14,730*	60.9	12,040*
	160	53.3	15,460*	55.8	14,380*	58.0	11,560*
	170	50.4	15,000*	52.8	13,780*	54.9	11,160*
	180	47.3	14,660*	49.7	13,160*	51.7	10,800*

	48	81.8	22,170*	-	-	-	-
	50	81.4	21,960*	-	-	-	-
	60	79.2	21,160*	81.7	18,910*	-	-
	70	76.9	20,440*	79.5	18,380*	81.9	16,710*
	80	74.6	19,760*	77.2	17,850*	79.6	16,330*
	90	72.3	19,200*	74.9	17,390*	77.3	15,910*
190' (57.9 m)	100	70.0	18,590*	72.5	16,950*	74.9	15,440*
	110	67.6	18,060*	70.1	16,530*	72.5	14,820*
	120	65.2	17,540*	67.7	16,030*	70.0	14,060*
	130	62.8	17,090*	65.2	15,630*	67.5	13,360*
	140	60.2	16,600*	62.7	15,200*	64.9	12,780*
	150	57.7	16,120*	60.1	14,870*	62.2	12,250*
	160	55.0	15,670*	57.4	14,540*	59.5	11,750*
	170	52.2	15,220*	54.6	14,120*	56.6	11,360*
	180	49.3	14,840*	51.7	13,490*	53.7	11,000*
	190	46.3	14,550*	48.6	12,910*	50.5	10,660*

	49	81.9	22,090*	-	-	-	-
	50	81.7	22,010*	-	-	-	-
	60	79.6	21,260*	-	-	-	-
	70	77.4	20,610*	79.9	18,440*	-	-
	80	75.2	19,960*	77.7	17,910*	80.0	16,350*
	90	73.0	19,310*	75.5	17,470*	77.8	15,920*
	100	70.8	18,710*	73.2	17,040*	75.5	15,500*
	110	68.5	18,220*	70.9	16,630*	73.2	15,010*
200' (61.0 m)	120	66.2	17,680*	68.6	16,210*	70.8	14,210*
	130	63.9	17,250*	66.2	15,770*	68.4	13,560*
	140	61.5	16,770*	63.8	15,330*	65.9	12,990*
	150	59.0	16,360*	61.3	14,960*	63.4	12,410*
	160	56.5	15,870*	58.8	14,670*	60.8	11,970*
	170	53.9	15,470*	56.2	14,380*	58.2	11,540*
	180	51.2	15,060*	53.4	13,830*	55.4	11,140*
	190	48.3	14,720*	50.6	13,230*	52.5	10,820*
	200	45.4	14,420*	47.6	12,760*	49.4	10,510*

Boom length	Jib Radius (Feet)	5.0 Deg offset		15.0 Deg offset		25.0 Deg offset	
		Boom Angle	Rating (Pounds)	Boom Angle	Rating (Pounds)	Boom Angle	Rating (Pounds)
	51	81.8	22,020*	-	-	-	-
	60	79.9	21,370*	-	-	-	-
	70	77.9	20,620*	80.2	18,420*	-	-
	80	75.8	19,980*	78.1	17,980*	80.4	16,310*
	90	73.6	19,380*	76.0	17,520*	78.2	15,980*
	100	71.5	18,840*	73.8	17,050*	76.0	15,560*
	110	69.3	18,360*	71.7	16,650*	73.8	15,200*
	120	67.1	17,810*	69.4	16,260*	71.6	14,390*
210' (64.0 m)	130	64.9	17,390*	67.2	15,830*	69.3	13,750*
	140	62.6	16,980*	64.9	15,460*	66.9	13,120*
	150	60.2	16,570*	62.5	15,110*	64.5	12,610*
	160	57.8	16,050*	60.1	14,750*	62.1	12,130*
	170	55.4	15,620*	57.6	14,490*	59.5	11,680*
	180	52.8	15,240*	55.0	14,150*	56.9	11,290*
	190	50.2	14,880*	52.3	13,570*	54.2	10,960*
	200	47.4	14,580*	49.6	13,030*	51.3	10,680*
	210	44.5	14,280*	46.6	12,580*	48.3	10,400*

	52	81.9	21,920*	-	-	-	-
	60	80.3	21,390*	-	-	-	-
	70	78.3	20,720*	80.6	18,490*	-	-
	80	76.3	20,080*	78.6	17,990*	80.7	16,340*
	90	74.2	19,490*	76.5	17,520*	78.6	15,970*
	100	72.2	18,980*	74.4	17,120*	76.5	15,610*
	110	70.1	18,430*	72.3	16,740*	74.4	15,250*
	120	67.9	17,990*	70.2	16,360*	72.2	14,590*
220' (67.1 m)	130	65.8	17,510*	68.0	15,990*	70.0	13,900*
	140	63.6	17,050*	65.8	15,570*	67.8	13,350*
	150	61.4	16,670*	63.6	15,210*	65.5	12,780*
	160	59.1	16,300*	61.2	14,870*	63.2	12,290*
	170	56.7	15,810*	58.9	14,560*	60.8	11,830*
	180	54.3	15,410	56.4	14,310*	58.3	11,440*
	190	51.8	15,080*	53.9	13,850*	55.7	11,120*
	200	49.2	14,770*	51.3	13,320*	53.1	10,800*
	210	46.5	14,460*	48.6	12,840*	50.3	10,520*
	220	43.7	14,160*	45.7	12,400*	47.3	10,290*

	53	82.0	21,880*	-	-	-	-
	60	80.6	21,400*	-	-	-	-
	70	78.7	20,730*	80.9	18,420*	-	-
	80	76.7	20,160*	78.9	17,970*	81.0	16,270*
	90	74.8	19,580*	77.0	17,560*	79.0	16,010*
	100	72.8	19,080*	75.0	17,130*	77.0	15,650*
	110	70.8	18,530*	72.9	16,750*	75.0	15,300*
	120	68.7	18,110*	70.9	16,450*	72.9	14,740*
230' (70.1 m)	130	66.6	17,610*	68.8	16,080*	70.8	14,120*
	140	64.5	17,230*	66.7	15,660*	68.6	13,510*
	150	62.4	16,820*	64.5	15,290*	66.4	12,960*
	160	60.2	16,420*	62.3	14,990*	64.2	12,440*
	170	58.0	16,000*	60.1	14,660*	61.9	12,010*
	180	55.7	15,620*	57.8	14,390*	59.6	11,610*
	190	53.3	15,240*	55.4	14,140*	57.1	11,260*
	200	50.9	14,930*	52.9	13,600*	54.6	10,920*
	210	48.3	14,620*	50.3	13,070*	52.0	10,640*
	220	45.7	14,320*	47.7	12,660*	49.3	10,410*
	230	42.9	13,420	44.9	12,260*	46.4	10,180*



WITH 92HI OFFSET TIP BOOM, 16HL JIB

195,000 lb + 64,000 lb CB

360°

ANSI B 30.5

70' (21.3 m) Jib length

Boom length	Jib Radius (Feet)	5.0 Deg offset		15.0 Deg offset		25.0 Deg offset	
		Boom Angle	Rating (Pounds)	Boom Angle	Rating (Pounds)	Boom Angle	Rating (Pounds)
	55	81.9	21,730*	-	-	-	-
	60	80.9	21,430*	-	-	-	-
	70	79.0	20,850*	81.2	18,420*	-	-
	80	77.2	20,250*	79.3	18,050*	81.3	16,240*
	90	75.3	19,650*	77.4	17,560*	79.4	16,010*
	100	73.3	19,100*	75.5	17,180*	77.5	15,700*
	110	71.4	18,680*	73.5	16,840*	75.5	15,340*
	120	69.4	18,170*	71.5	16,510*	73.5	14,930*
240' (73.2 m)	130	67.4	17,700*	69.5	16,150*	71.5	14,280*
	140	65.4	17,350*	67.5	15,800*	69.4	13,630*
	150	63.4	16,890*	65.4	15,400*	67.3	13,090*
	160	61.3	16,570*	63.3	15,060*	65.1	12,590*
	170	59.1	16,210*	61.2	14,800*	63.0	12,160*
	180	56.9	15,770*	59.0	14,520*	60.7	11,740*
	190	54.7	15,390*	56.7	14,270*	58.4	11,380*
	200	52.4	15,080*	54.3	13,830*	56.0	11,090*
	210	50.0	14,780*	51.9	13,350*	53.6	10,760*
	220	47.5	14,150	49.4	12,870*	51.0	10,530*
	230	44.9	12,870	46.8	12,470*	48.3	10,300*
	240	42.2	11,710	44.0	11,720	45.5	10,080*

	56	81.9	21,800*	-	-	-	-
	60	81.2	21,540*	-	-	-	-
	70	79.4	20,870*	81.5	18,490*	-	-
	80	77.6	20,330*	79.7	18,070*	81.6	16,280*
	90	75.7	19,720*	77.8	17,630*	79.8	15,980*
	100	73.9	19,200*	75.9	17,230*	77.9	15,730*
	110	72.0	18,730*	74.1	16,900*	76.0	15,380*
	120	70.1	18,300*	72.1	16,540*	74.0	15,040*
	130	68.2	17,850*	70.2	16,180*	72.1	14,390*
	140	66.2	17,440*	68.3	15,870*	70.1	13,790*
250' (76.2 m)	150	64.3	17,070*	66.3	15,530*	68.1	13,270*
	160	62.2	16,650*	64.2	15,210*	66.0	12,750*
	170	60.2	16,360*	62.2	14,870*	63.9	12,330*
	180	58.1	15,990*	60.1	14,620*	61.8	11,900*
	190	56.0	15,600*	57.9	14,370*	59.6	11,550*
	200	53.7	15,220*	55.7	14,120*	57.3	11,210*
	210	51.5	14,910*	53.4	13,580*	55.0	10,890*
	220	49.1	13,580	51.0	13,160*	52.6	10,650*
	230	46.7	12,290	48.5	12,300	50.1	10,420*
	240	44.1	11,130	46.0	11,140	47.4	10,190*
	250	41.5	10,060	43.3	10,070	44.7	10,010*

Boom length	Jib Radius (Feet)	5.0 Deg offset		15.0 Deg offset		25.0 Deg offset	
		Boom Angle	Rating (Pounds)	Boom Angle	Rating (Pounds)	Boom Angle	Rating (Pounds)
	57	82.0	21,710*	-	-	-	-
	60	81.5	21,470*	-	-	-	-
	70	79.7	20,920*	81.7	18,480*	-	-
	80	77.9	20,330*	80.0	18,070*	81.9	16,270*
	90	76.2	19,800*	78.2	17,620*	80.1	15,950*
	100	74.4	19,330*	76.4	17,280*	78.3	15,700*
	110	72.6	18,850*	74.6	16,940*	76.4	15,410*
	120	70.7	18,370*	72.7	16,560*	74.5	15,130*
	130	68.9	17,910*	70.9	16,250*	72.7	14,530*
	140	67.0	17,570*	69.0	15,980*	70.8	13,920*
260' (79.2 m)	150	65.1	17,130*	67.0	15,610*	68.8	13,410*
	160	63.2	16,770*	65.1	15,270*	66.8	12,890*
	170	61.2	16,460*	63.1	14,950*	64.8	12,480*
	180	59.2	16,150*	61.1	14,690*	62.8	12,070*
	190	57.1	15,760*	59.0	14,440*	60.7	11,660*
	200	55.0	15,380*	56.9	14,190*	58.5	11,350*
	210	52.9	14,460	54.7	13,870*	56.3	11,010*
	220	50.6	13,020	52.5	13,030	54.0	10,770*
	230	48.3	11,740	50.1	11,750	51.6	10,490*
	240	45.9	10,570	47.7	10,580	49.2	10,300*
	250	43.4	9,500	45.2	9,510	46.6	9,530
	260	40.8	8,530	42.5	8,550	43.9	8,570

	59	81.9	21,570*	-	-	-	-
	60	81.7	21,480*	-	-	-	-
	70	80.0	20,930*	82.0	18,470*	-	-
	80	78.3	20,410*	80.3	18,060*	-	-
	90	76.6	19,870*	78.5	17,680*	80.4	15,980*
	100	74.8	19,360*	76.8	17,330*	78.6	15,660*
	110	73.1	18,870*	75.0	16,950*	76.8	15,440*
	120	71.3	18,480*	73.3	16,630*	75.0	15,130*
	130	69.5	18,040*	71.5	16,340*	73.2	14,720*
	140	67.7	17,620*	69.6	16,010*	71.4	14,120*
270' (82.3 m)	150	65.9	17,210*	67.8	15,730*	69.5	13,520*
	160	64.0	16,910*	65.9	15,390*	67.6	13,050*
	170	62.1	16,550*	64.0	15,090*	65.7	12,600*
	180	60.2	16,230*	62.0	14,770*	63.7	12,180*
	190	58.2	15,910*	60.1	14,540*	61.7	11,820*
	200	56.2	15,480	58.0	14,290*	59.6	11,470*
	210	54.1	13,900	55.9	13,910	57.5	11,170*
	220	52.0	12,470	53.8	12,480	55.3	10,850*
	230	49.8	11,180	51.6	11,190	53.1	10,610*
	240	47.5	10,020	49.3	10,030	50.7	10,050
	250	45.2	8,940	46.9	8,950	48.3	8,980
	260	42.7	7,970	44.4	7,980	45.8	8,010
	270	40.1	7,080	41.8	7,090	43.1	7,110

WITH 92HI OFFSET TIP BOOM, 16HL JIB

195,000 lb + 64,000 lb CB

360°

ANSI B 30.5

70' (21.3 m) Jib length

Boom length	Jib Radius (Feet)	5.0 Deg offset		15.0 Deg offset		25.0 Deg offset	
		Boom Angle	Rating (Pounds)	Boom Angle	Rating (Pounds)	Boom Angle	Rating (Pounds)
	60	82.0	21,460*	-	-	-	-
	70	80.3	20,900*	-	-	-	-
	80	78.6	20,400*	80.6	17,990*	-	-
	90	77.0	19,830*	78.9	17,630*	80.7	15,920*
	100	75.3	19,370*	77.2	17,280*	79.0	15,630*
	110	73.6	18,970*	75.5	16,950*	77.2	15,380*
	120	71.9	18,510*	73.8	16,590*	75.5	15,180*
	130	70.1	18,100*	72.0	16,290*	73.7	14,850*
	140	68.4	17,710*	70.2	16,060*	71.9	14,720*
	150	66.6	17,310*	68.5	15,730*	70.1	13,680*
280' (85.3 m)	160	64.8	16,950*	66.6	15,490*	68.3	13,180*
	170	63.0	16,640*	64.8	15,190*	66.4	12,720*
	180	61.1	16,310*	62.9	14,870*	64.5	12,290*
	190	59.2	15,990*	61.0	14,610*	62.6	11,930*
	200	57.3	15,110	59.1	14,360*	60.6	11,570*
	210	55.3	13,520	57.1	13,530	58.6	11,270*
	220	53.3	12,090	55.0	12,100	56.5	10,980*
	230	51.2	10,800	52.9	10,810	54.4	10,740*
	240	49.0	9,630	50.8	9,640	52.2	9,660
	250	46.8	8,560	48.5	8,570	49.9	8,590
	260	44.5	7,580	46.2	7,590	47.5	7,620
	270	42.1	6,680	43.7	6,700	45.0	6,720
	280	39.5	5,860	41.1	5,870	42.4	5,900

Boom length	Jib Radius (Feet)	5.0 Deg offset		15.0 Deg offset		25.0 Deg offset	
		Boom Angle	Rating (Pounds)	Boom Angle	Rating (Pounds)	Boom Angle	Rating (Pounds)
	62	81.9	21,310*	-	-	-	-
	70	80.6	20,880*	-	-	-	-
	80	79.0	20,400*	80.8	17,960*	-	-
	90	77.3	19,890*	79.2	17,600*	80.9	15,880*
	100	75.7	19,470*	77.5	17,250*	79.3	15,590*
	110	74.1	18,980*	75.9	16,950*	77.6	15,410*
	120	72.4	18,530*	74.2	16,620*	75.9	15,160*
	130	70.7	18,120*	72.5	16,360*	74.2	14,930*
	140	69.0	17,770*	70.8	16,050*	72.5	14,370*
	150	67.3	17,350*	69.1	15,780*	70.7	13,810*
290' (88.4 m)	160	65.6	17,030*	67.3	15,530*	69.0	13,340*
	170	63.8	16,710*	65.6	15,270*	67.2	12,840*
	180	62.0	16,400*	63.8	14,950*	65.3	12,460*
	190	60.2	16,080*	61.9	14,690*	63.5	12,040*
	200	58.3	14,570	60.1	14,460*	61.6	11,680*
	210	56.4	12,980	58.1	12,990	59.6	11,390*
	220	54.5	11,550	56.2	11,560	57.6	11,090*
	230	52.5	10,260	54.2	10,270	55.6	10,290
	240	50.4	9,090	52.1	9,100	53.5	9,120
	250	48.3	8,020	50.0	8,030	51.3	8,050
	260	46.1	7,040	47.8	7,050	49.1	7,070
	270	43.8	6,130	45.5	6,150	46.7	6,170
	280	41.4	5,230*	43.0	5,320	44.3	5,340
	290	38.9	4,190*	40.5	4,560	41.7	4,580

80' (24.4 m) Jib length

Boom length	Jib Radius (Feet)	5.0 Deg offset		15.0 Deg offset		25.0 Deg offset	
		Boom Angle	Rating (Pounds)	Boom Angle	Rating (Pounds)	Boom Angle	Rating (Pounds)
	51	82.0	17,300*	-	-	-	-
	60	80.1	16,660*	-	-	-	-
	70	78.0	16,040*	80.8	14,050*	-	-
	80	75.9	15,460*	78.7	13,640*	81.2	11,980*
	90	73.8	14,890*	76.5	13,120*	79.1	11,590*
	100	71.7	14,350*	74.4	12,670*	76.9	11,260*
	110	69.5	13,870*	72.2	12,210*	74.7	10,950*
	120	67.3	13,370*	69.9	11,790*	72.4	10,640*
200' (61.0 m)	130	65.0	12,860*	67.7	11,430*	70.1	10,370*
	140	62.7	12,410*	65.4	11,110*	67.8	10,150*
	150	60.4	11,950*	63.0	10,810*	65.4	9,950*
	160	58.0	11,560*	60.6	10,520*	62.9	9,760*
	170	55.5	11,190*	58.1	10,280*	60.3	9,620*
	180	53.0	10,880*	55.5	10,050*	57.7	9,470*
	190	50.3	10,600*	52.8	9,880*	55.0	9,380*
	200	47.6	10,370*	50.1	9,720*	52.1	9,230*

Boom length	Jib Radius (Feet)	5.0 Deg offset		15.0 Deg offset		25.0 Deg offset	
		Boom Angle	Rating (Pounds)	Boom Angle	Rating (Pounds)	Boom Angle	Rating (Pounds)
	53	81.9	17,240*	-	-	-	-
	60	80.5	16,770*	-	-	-	-
	70	78.5	16,130*	81.1	14,070*	-	-
	80	76.4	15,540*	79.1	13,640*	81.6	11,990*
	90	74.4	14,950*	77.0	13,180*	79.5	11,590*
	100	72.3	14,470*	74.9	12,700*	77.4	11,260*
	110	70.2	13,960*	72.8	12,290*	75.2	10,970*
	120	68.1	13,510*	70.7	11,900*	73.1	10,660*
210' (64.0 m)	130	66.0	13,000*	68.5	11,500*	70.9	10,420*
	140	63.8	12,550*	66.3	11,190*	68.6	10,210*
	150	61.5	12,100*	64.0	10,900*	66.3	9,980*
	160	59.2	11,710*	61.7	10,600*	64.0	9,800*
	170	56.9	11,340*	59.4	10,390*	61.6	9,630*
	180	54.5	11,020*	56.9	10,140*	59.1	9,520*
	190	52.0	10,730*	54.4	9,950*	56.5	9,370*
	200	49.4	10,490*	51.8	9,760*	53.8	9,290*
	210	46.7	10,250*	49.1	9,620*	51.0	9,090*



WITH 92HI OFFSET TIP BOOM, 16HL JIB

195,000 lb + 64,000 lb CB

360°

ANSI B 30.5

80' (24.4 m) Jib length

Boom length	Jib Radius (Feet)	5.0 Deg offset		15.0 Deg offset		25.0 Deg offset	
		Boom Angle	Rating (Pounds)	Boom Angle	Rating (Pounds)	Boom Angle	Rating (Pounds)
	54	81.9	17,180*	-	-	-	-
	60	80.8	16,820*	-	-	-	-
	70	78.8	16,150*	81.4	14,090*	-	-
	80	76.9	15,610*	79.4	13,650*	81.8	12,000*
	90	74.9	15,030*	77.5	13,250*	79.8	11,630*
	100	72.9	14,570*	75.5	12,770*	77.8	11,310*
	110	70.9	14,070*	73.4	12,340*	75.8	10,980*
	120	68.9	13,630*	71.4	11,940*	73.7	10,730*
220' (67.1 m)	130	66.8	13,160*	69.3	11,610*	71.6	10,460*
	140	64.7	12,720*	67.2	11,260*	69.4	10,220*
	150	62.6	12,290*	65.0	10,960*	67.2	10,040*
	160	60.4	11,880*	62.8	10,680*	65.0	9,850*
	170	58.1	11,530*	60.5	10,430*	62.7	9,670*
	180	55.8	11,170*	58.2	10,240*	60.3	9,550*
	190	53.5	10,900*	55.8	10,030*	57.9	9,400*
	200	51.0	10,610*	53.4	9,830*	55.4	9,310*
	210	48.5	10,380*	50.8	9,700*	52.7	9,190*
	220	45.8	10,140*	48.1	9,550*	50.0	8,990*

	56	81.8	17,090*	-	-	-	-
	60	81.1	16,820*	-	-	-	-
	70	79.2	16,210*	81.7	14,100*	-	-
	80	77.3	15,610*	79.8	13,690*	-	-
	90	75.4	15,110*	77.9	13,300*	80.2	11,620*
	100	73.5	14,610*	75.9	12,830*	78.2	11,300*
	110	71.6	14,180*	74.0	12,430*	76.2	11,020*
	120	69.6	13,750*	72.0	12,040*	74.2	10,760*
230' (70.1 m)	130	67.6	13,300*	70.0	11,670*	72.2	10,490*
	140	65.6	12,830*	68.0	11,340*	70.1	10,270*
	150	63.5	12,410*	65.9	11,060*	68.0	10,060*
	160	61.4	12,040*	63.8	10,760*	65.9	9,850*
	170	59.3	11,650*	61.6	10,520*	63.7	9,700*
	180	57.1	11,320*	59.4	10,290*	61.5	9,560*
	190	54.8	11,020*	57.1	10,060*	59.1	9,440*
	200	52.5	10,730*	54.8	9,920*	56.8	9,330*
	210	50.1	10,500*	52.4	9,730*	54.3	9,250*
	220	47.6	10,260*	49.9	9,580*	51.7	9,080*
230	45.0	10,040*	47.2	9,480*	49.0	8,880*	

	57	81.9	17,010*	-	-	-	-
	60	81.4	16,860*	-	-	-	-
	70	79.5	16,220*	81.9	14,060*	-	-
	80	77.7	15,680*	80.1	13,690*	-	-
	90	75.9	15,150*	78.3	13,300*	80.5	11,670*
	100	74.0	14,700*	76.4	12,900*	78.6	11,350*
	110	72.2	14,220*	74.5	12,470*	76.7	11,030*
	120	70.3	13,800*	72.6	12,130*	74.8	10,780*
240' (73.2 m)	130	68.3	13,430*	70.7	11,770*	72.8	10,520*
	140	66.4	13,010*	68.7	11,420*	70.8	10,300*
	150	64.4	12,530*	66.7	11,130*	68.8	10,080*
	160	62.4	12,170*	64.7	10,860*	66.8	9,880*
	170	60.4	11,780*	62.6	10,600*	64.7	9,730*
	180	58.3	11,440*	60.5	10,340*	62.5	9,580*
	190	56.1	11,120*	58.3	10,150*	60.3	9,460*
	200	53.9	10,870*	56.1	9,950*	58.0	9,320*
	210	51.6	10,580*	53.8	9,800*	55.7	9,230*
	220	49.3	10,340*	51.4	9,660*	53.3	9,150*
230	46.8	10,150*	49.0	9,510*	50.7	8,980*	
240	44.3	9,970*	46.4	9,420*	48.1	8,780*	

Boom length	Jib Radius (Feet)	5.0 Deg offset		15.0 Deg offset		25.0 Deg offset	
		Boom Angle	Rating (Pounds)	Boom Angle	Rating (Pounds)	Boom Angle	Rating (Pounds)
	58	82.0	17,000*	-	-	-	-
	60	81.6	16,900*	-	-	-	-
	70	79.9	16,300*	-	-	-	-
	80	78.1	15,750*	80.4	13,690*	-	-
	90	76.3	15,240*	78.6	13,360*	80.8	11,660*
	100	74.5	14,780*	76.8	12,970*	79.0	11,340*
	110	72.7	14,340*	75.0	12,560*	77.1	11,080*
	120	70.9	13,900*	73.2	12,150*	75.3	10,800*
	130	69.0	13,540*	71.3	11,820*	73.4	10,530*
	140	67.2	13,150*	69.4	11,510*	71.5	10,320*
250' (76.2 m)	150	65.2	12,680*	67.5	11,180*	69.5	10,140*
	160	63.3	12,310*	65.5	10,910*	67.5	9,910*
	170	61.3	11,910*	63.5	10,640*	65.5	9,760*
	180	59.3	11,590*	61.5	10,430*	63.5	9,610*
	190	57.3	11,240*	59.4	10,230*	61.4	9,470*
	200	55.2	10,990*	57.3	10,030*	59.2	9,350*
	210	53.0	10,700*	55.1	9,840*	57.0	9,250*
	220	50.8	10,460*	52.9	9,690*	54.7	9,170*
	230	48.5	10,270*	50.6	9,550*	52.3	9,040*
	240	46.1	10,040*	48.1	9,440*	49.8	8,840*
250	43.6	9,900*	45.6	9,360*	47.2	8,670*	

	60	81.9	16,900*	-	-	-	-
	70	80.2	16,300*	-	-	-	-
	80	78.5	15,810*	80.7	13,680*	-	-
	90	76.7	15,330*	79.0	13,350*	81.1	11,660*
	100	75.0	14,850*	77.2	13,000*	79.3	11,340*
	110	73.2	14,410*	75.5	12,630*	77.5	11,090*
	120	71.5	13,990*	73.7	12,210*	75.7	10,810*
	130	69.7	13,600*	71.9	11,890*	73.9	10,540*
	140	67.9	13,220*	70.1	11,540*	72.1	10,360*
	150	66.0	12,810*	68.2	11,260*	70.2	10,130*
260' (79.2 m)	160	64.2	12,420*	66.3	10,990*	68.3	9,950*
	170	62.3	12,070*	64.4	10,710*	66.3	9,760*
	180	60.3	11,710*	62.5	10,510*	64.4	9,610*
	190	58.4	11,410*	60.5	10,260*	62.3	9,500*
	200	56.3	11,110*	58.4	10,060*	60.3	9,380*
	210	54.3	10,820*	56.4	9,910*	58.2	9,280*
	220	52.1	10,580*	54.2	9,720*	56.0	9,190*
	230	50.0	10,350*	52.0	9,620*	53.7	9,100*
	240	47.7	10,160*	49.7	9,470*	51.4	8,940*
	250	45.3	9,740	47.3	9,380*	48.9	8,780*
260	42.9	8,770	44.8	8,780	46.4	8,620*	

WITH 92HI OFFSET TIP BOOM, 16HL JIB

195,000 lb + 64,000 lb CB

360°

ANSI B 30.5

80' (24.4 m) Jib length

Boom length	Jib Radius (Feet)	5.0 Deg offset		15.0 Deg offset		25.0 Deg offset	
		Boom Angle	Rating (Pounds)	Boom Angle	Rating (Pounds)	Boom Angle	Rating (Pounds)
	61	81.9	16,890*	-	-	-	-
	70	80.4	16,340*	-	-	-	-
	80	78.8	15,820*	81.0	13,710*	-	-
	90	77.1	15,340*	79.3	13,350*	81.4	11,650*
	100	75.4	14,920*	77.6	13,010*	79.6	11,380*
	110	73.7	14,470*	75.9	12,680*	77.9	11,100*
	120	72.0	14,060*	74.2	12,270*	76.2	10,810*
	130	70.3	13,650*	72.4	11,960*	74.4	10,590*
	140	68.5	13,310*	70.7	11,640*	72.6	10,360*
	150	66.8	12,950*	68.9	11,310*	70.8	10,140*
270' (82.3 m)	160	65.0	12,550*	67.1	11,040*	69.0	9,950*
	170	63.1	12,190*	65.2	10,800*	67.1	9,800*
	180	61.3	11,820*	63.3	10,550*	65.2	9,650*
	190	59.4	11,510*	61.4	10,350*	63.3	9,490*
	200	57.4	11,210*	59.5	10,150*	61.3	9,390*
	210	55.5	10,910*	57.5	9,950*	59.2	9,270*
	220	53.4	10,670*	55.4	9,800*	57.2	9,170*
	230	51.3	10,470*	53.3	9,650*	55.0	9,080*
	240	49.2	10,230*	51.2	9,510*	52.8	9,040*
	250	46.9	9,190	48.9	9,200	50.5	8,840*
	260	44.6	8,210	46.6	8,230	48.1	8,250
	270	42.2	7,310	44.1	7,330	45.6	7,350

	63	81.8	16,740*	-	-	-	-
	70	80.7	16,320*	-	-	-	-
	80	79.1	15,810*	81.2	13,660*	-	-
	90	77.5	15,400*	79.6	13,320*	81.6	11,650*
	100	75.8	14,910*	78.0	13,060*	79.9	11,350*
	110	74.2	14,470*	76.3	12,730*	78.3	11,090*
	120	72.5	14,110*	74.6	12,320*	76.6	10,850*
	130	70.9	13,700*	72.9	11,970*	74.9	10,580*
	140	69.2	13,370*	71.2	11,680*	73.1	10,360*
	150	67.4	13,030*	69.5	11,370*	71.4	10,160*
280' (85.3 m)	160	65.7	12,640*	67.7	11,090*	69.6	10,010*
	170	63.9	12,300*	66.0	10,850*	67.8	9,800*
	180	62.1	11,930*	64.2	10,590*	66.0	9,680*
	190	60.3	11,630*	62.3	10,380*	64.1	9,520*
	200	58.4	11,330*	60.4	10,180*	62.2	9,420*
	210	56.5	11,030*	58.5	10,030*	60.3	9,300*
	220	54.6	10,790*	56.6	9,830*	58.3	9,200*
	230	52.6	10,550*	54.6	9,690*	56.2	9,110*
	240	50.6	9,870	52.5	9,540*	54.1	9,020*
	250	48.4	8,800	50.4	8,810	51.9	8,840
	260	46.2	7,820	48.1	7,830	49.7	7,850
	270	44.0	6,920	45.8	6,940	47.3	6,960
	280	41.6	6,100	43.4	6,110	44.8	6,140

Boom length	Jib Radius (Feet)	5.0 Deg offset		15.0 Deg offset		25.0 Deg offset	
		Boom Angle	Rating (Pounds)	Boom Angle	Rating (Pounds)	Boom Angle	Rating (Pounds)
	64	81.9	16,680*	-	-	-	-
	70	81.0	16,390*	-	-	-	-
	80	79.4	15,900*	81.5	13,660*	-	-
	90	77.8	15,390*	79.9	13,330*	81.8	11,640*
	100	76.2	14,960*	78.3	13,050*	80.2	11,390*
	110	74.6	14,530*	76.7	12,720*	78.6	11,080*
	120	73.0	14,130*	75.1	12,390*	77.0	10,850*
	130	71.4	13,780*	73.4	12,030*	75.3	10,620*
	140	69.7	13,420*	71.8	11,730*	73.6	10,370*
	150	68.1	13,130*	70.1	11,400*	71.9	10,190*
290' (88.4 m)	160	66.4	12,800*	68.4	11,130*	70.2	10,000*
	170	64.7	12,410*	66.7	10,880*	68.5	9,840*
	180	63.0	12,050*	64.9	10,670*	66.7	9,680*
	190	61.2	11,740*	63.2	10,420*	64.9	9,520*
	200	59.4	11,430*	61.4	10,220*	63.1	9,410*
	210	57.6	11,130*	59.5	10,060*	61.2	9,310*
	220	55.7	10,880*	57.6	9,870*	59.3	9,190*
	230	53.8	10,510	55.7	9,720*	57.3	9,090*
	240	51.8	9,340	53.7	9,350	55.3	9,040*
	250	49.8	8,260	51.7	8,270	53.2	8,290
	260	47.7	7,280	49.6	7,290	51.1	7,320
	270	45.6	6,380	47.4	6,390	48.9	6,410
	280	43.3	5,530*	45.1	5,560	46.6	5,590
	290	41.0	4,520*	42.8	4,790	44.1	4,820

WITH 92HI OFFSET TIP BOOM, 16HL JIB

195,000 lb + 64,000 lb CB

360°

ANSI B 30.5

90' (27.4 m) Jib length

Boom length	Jib Radius (Feet)	5.0 Deg offset		15.0 Deg offset		25.0 Deg offset	
		Boom Angle	Rating (Pounds)	Boom Angle	Rating (Pounds)	Boom Angle	Rating (Pounds)
	58	81.9	13,670*	-	-	-	-
	60	81.5	13,560*	-	-	-	-
	70	79.7	13,000*	-	-	-	-
	80	77.9	12,500*	80.6	10,360*	-	-
	90	76.0	11,890*	78.7	9,920*	81.3	8,500*
	100	74.2	11,360*	76.9	9,520*	79.4	8,230*
	110	72.3	10,840*	75.0	9,150*	77.5	7,980*
	120	70.4	10,340*	73.1	8,830*	75.5	7,750*
230' (70.1 m)	130	68.5	9,930*	71.1	8,540*	73.6	7,550*
	140	66.5	9,520*	69.2	8,280*	71.6	7,360*
	150	64.6	9,190*	67.2	8,030*	69.5	7,170*
	160	62.6	8,830*	65.1	7,800*	67.5	7,020*
	170	60.5	8,530*	63.1	7,570*	65.4	6,900*
	180	58.4	8,260*	61.0	7,390*	63.2	6,770*
	190	56.3	8,030*	58.8	7,240*	61.0	6,640*
	200	54.0	7,780*	56.6	7,070*	58.7	6,560*
	210	51.8	7,570*	54.3	6,930*	56.4	6,480*
	220	49.4	7,410*	51.9	6,830*	54.0	6,410*
	230	47.0	7,210*	49.4	6,690*	51.4	6,360*

	59	81.9	13,600*	-	-	-	-
	60	81.8	13,560*	-	-	-	-
	70	80.0	13,020*	-	-	-	-
	80	78.2	12,510*	80.9	10,380*	-	-
	90	76.5	12,010*	79.1	9,940*	81.5	8,500*
	100	74.7	11,450*	77.3	9,540*	79.7	8,250*
	110	72.9	10,910*	75.4	9,220*	77.9	8,000*
	120	71.0	10,440*	73.6	8,900*	76.0	7,780*
240' (73.2 m)	130	69.2	10,040*	71.7	8,580*	74.1	7,570*
	140	67.3	9,630*	69.8	8,340*	72.2	7,390*
	150	65.4	9,260*	67.9	8,060*	70.2	7,210*
	160	63.5	8,950*	66.0	7,860*	68.3	7,040*
	170	61.5	8,650*	64.0	7,630*	66.2	6,890*
	180	59.5	8,360*	62.0	7,430*	64.2	6,760*
	190	57.4	8,110*	59.9	7,280*	62.1	6,650*
	200	55.3	7,890*	57.8	7,110*	59.9	6,570*
	210	53.1	7,650*	55.6	6,970*	57.7	6,480*
	220	50.9	7,480*	53.3	6,840*	55.4	6,400*
	230	48.6	7,280*	51.0	6,740*	53.0	6,350*
	240	46.2	7,160*	48.6	6,640*	50.5	6,310*

	61	81.8	13,550*	-	-	-	-
	70	80.3	13,100*	-	-	-	-
	80	78.6	12,560*	81.1	10,400*	-	-
	90	76.9	12,120*	79.4	9,990*	81.8	8,480*
	100	75.1	11,560*	77.7	9,600*	80.0	8,220*
	110	73.4	11,030*	75.9	9,230*	78.2	8,010*
	120	71.6	10,570*	74.1	8,930*	76.4	7,780*
	130	69.8	10,120*	72.3	8,640*	74.6	7,570*
	140	68.0	9,720*	70.5	8,370*	72.8	7,370*
	150	66.2	9,360*	68.6	8,110*	70.9	7,200*
250' (76.2 m)	160	64.3	9,030*	66.7	7,870*	69.0	7,050*
	170	62.4	8,730*	64.8	7,680*	67.0	6,920*
	180	60.5	8,440*	62.9	7,480*	65.0	6,770*
	190	58.5	8,180*	60.9	7,300*	63.0	6,660*
	200	56.5	7,950*	58.9	7,160*	61.0	6,560*
	210	54.4	7,740*	56.8	7,020*	58.8	6,480*
	220	52.3	7,560*	54.6	6,880*	56.6	6,400*
	230	50.1	7,360*	52.4	6,780*	54.4	6,350*
	240	47.8	7,230*	50.1	6,660*	52.0	6,310*
	250	45.5	7,060*	47.7	6,590*	49.6	6,270*

Boom length	Jib Radius (Feet)	5.0 Deg offset		15.0 Deg offset		25.0 Deg offset	
		Boom Angle	Rating (Pounds)	Boom Angle	Rating (Pounds)	Boom Angle	Rating (Pounds)
	62	81.9	13,530*	-	-	-	-
	70	80.6	13,110*	-	-	-	-
	80	78.9	12,610*	81.4	10,410*	-	-
	90	77.3	12,140*	79.7	9,980*	-	-
	100	75.6	11,610*	78.0	9,610*	80.3	8,240
	110	73.9	11,110*	76.3	9,260*	78.6	7,980
	120	72.2	10,650*	74.6	8,980*	76.8	7,790
	130	70.4	10,210*	72.8	8,680*	75.1	7,580
	140	68.7	9,830*	71.1	8,400*	73.3	7,390
	150	66.9	9,480*	69.3	8,150*	71.5	7,200
260' (79.2 m)	160	65.1	9,140*	67.5	7,920*	69.6	7,080
	170	63.3	8,820*	65.6	7,710*	67.8	6,930
	180	61.4	8,550*	63.8	7,530*	65.9	6,780
	190	59.5	8,280*	61.8	7,350*	63.9	6,680
	200	57.6	8,060*	59.9	7,200*	61.9	6,570
	210	55.6	7,810*	57.9	7,030*	59.9	6,490
	220	53.6	7,640*	55.8	6,920*	57.8	6,400
	230	51.5	7,430*	53.7	6,790*	55.7	6,350
	240	49.3	7,270*	51.6	6,690*	53.4	6,300
	250	47.1	7,140*	49.3	6,590*	51.1	6,260
	260	44.8	6,980*	47.0	6,510*	48.7	6,220

	63	82.0	13,450*	-	-	-	-
	70	80.9	13,110*	-	-	-	-
	80	79.2	12,660*	81.6	10,430*	-	-
	90	77.6	12,190*	80.0	10,000*	-	-
	100	76.0	11,710*	78.4	9,660*	80.6	8,210
	110	74.3	11,220*	76.7	9,310*	78.9	7,990
	120	72.7	10,720*	75.0	8,990*	77.2	7,760
	130	71.0	10,310*	73.3	8,690*	75.5	7,590
	140	69.3	9,940*	71.6	8,430*	73.8	7,410
	150	67.6	9,580*	69.9	8,190*	72.0	7,230
270' (82.3 m)	160	65.8	9,220*	68.1	7,950*	70.3	7,070
	170	64.1	8,930*	66.4	7,770*	68.5	6,910
	180	62.3	8,620*	64.6	7,580*	66.6	6,800
	190	60.4	8,360*	62.7	7,400*	64.8	6,690
	200	58.6	8,140*	60.8	7,220*	62.8	6,580
	210	56.7	7,930*	58.9	7,070*	60.9	6,480
	220	54.7	7,690*	57.0	6,940*	58.9	6,400
	230	52.7	7,520*	55.0	6,830*	56.8	6,340
	240	50.7	7,340*	52.9	6,730*	54.7	6,270
	250	48.6	7,180*	50.7	6,610*	52.5	6,220
	260	46.4	7,050*	48.5	6,540*	50.3	6,210
	270	44.1	6,930*	46.2	6,460*	47.9	6,170

WITH 92HI OFFSET TIP BOOM, 16HL JIB

195,000 lb + 64,000 lb CB

360°

ANSI B 30.5

90' (27.4 m) Jib length

Boom length	Jib Radius (Feet)	5.0 Deg offset		15.0 Deg offset		25.0 Deg offset	
		Boom Angle	Rating (Pounds)	Boom Angle	Rating (Pounds)	Boom Angle	Rating (Pounds)
	65	81.9	13,340*	-	-	-	-
	70	81.1	13,120*	-	-	-	-
	80	79.5	12,650*	81.9	10,430*	-	-
	90	78.0	12,220*	80.3	10,030*	-	-
	100	76.4	11,830*	78.7	9,690*	80.9	8,220*
	110	74.8	11,280*	77.1	9,350*	79.2	7,990*
	120	73.2	10,830*	75.5	9,050*	77.6	7,790*
	130	71.5	10,420*	73.8	8,750*	75.9	7,590*
	140	69.9	10,000*	72.2	8,490*	74.3	7,390*
	150	68.2	9,630*	70.5	8,230*	72.6	7,230*
280' (85.3 m)	160	66.5	9,310*	68.8	8,020*	70.8	7,070*
	170	64.8	9,020*	67.1	7,810*	69.1	6,930*
	180	63.1	8,740*	65.3	7,590*	67.3	6,820*
	190	61.3	8,470*	63.5	7,410*	65.5	6,700*
	200	59.5	8,200*	61.7	7,260*	63.7	6,570*
	210	57.7	7,980*	59.9	7,120*	61.8	6,490*
	220	55.8	7,770*	58.0	6,980*	59.9	6,410*
	230	53.9	7,590*	56.1	6,840*	57.9	6,320*
	240	52.0	7,420*	54.1	6,740*	55.9	6,270*
	250	49.9	7,250*	52.1	6,640*	53.8	6,220*
	260	47.9	7,120*	50.0	6,540*	51.7	6,170*
	270	45.7	6,990*	47.8	6,490*	49.5	6,160*
	280	43.5	6,300	45.5	6,310	47.1	6,150*

Boom length	Jib Radius (Feet)	5.0 Deg offset		15.0 Deg offset		25.0 Deg offset	
		Boom Angle	Rating (Pounds)	Boom Angle	Rating (Pounds)	Boom Angle	Rating (Pounds)
	66	81.9	13,290*	-	-	-	-
	70	81.3	13,130*	-	-	-	-
	80	79.8	12,650*	-	-	-	-
	90	78.3	12,260*	80.5	10,040*	-	-
	100	76.7	11,830*	79.0	9,690*	81.1	8,190*
	110	75.2	11,380*	77.4	9,350*	79.5	7,990*
	120	73.6	10,920*	75.8	9,060*	77.9	7,900*
	130	72.0	10,490*	74.3	8,760*	76.3	7,590*
	140	70.4	10,110*	72.7	8,530*	74.7	7,390*
	150	68.8	9,740*	71.0	8,270*	73.1	7,230*
290' (88.4 m)	160	67.2	9,410*	69.4	8,020*	71.4	7,080*
	170	65.5	9,070*	67.7	7,830*	69.7	6,950*
	180	63.9	8,810*	66.0	7,650*	68.0	6,800*
	190	62.2	8,540*	64.3	7,460*	66.3	6,680*
	200	60.4	8,280*	62.6	7,280*	64.5	6,580*
	210	58.7	8,060*	60.8	7,140*	62.7	6,500*
	220	56.9	7,840*	59.0	6,990*	60.8	6,400*
	230	55.0	7,670*	57.1	6,890*	59.0	6,320*
	240	53.1	7,460*	55.2	6,750*	57.0	6,260*
	250	51.2	7,330*	53.3	6,640*	55.0	6,220*
	260	49.2	7,160*	51.3	6,560*	53.0	6,170*
	270	47.2	6,580	49.2	6,490*	50.9	6,120*
	280	45.1	5,760	47.1	5,770	48.7	5,800
	290	42.8	4,780*	44.8	5,000	46.4	5,030

100' (30.5 m) Jib length

Boom length	Jib Radius (Feet)	5.0 Deg offset		15.0 Deg offset		25.0 Deg offset	
		Boom Angle	Rating (Pounds)	Boom Angle	Rating (Pounds)	Boom Angle	Rating (Pounds)
	63	81.9	10,240*	-	-	-	-
	70	80.7	9,810*	-	-	-	-
	80	79.1	9,270*	81.8	7,330*	-	-
	90	77.4	8,730*	80.1	6,990*	-	-
	100	75.7	8,290*	78.4	6,710*	81.0	5,600*
	110	74.0	7,860*	76.7	6,410*	79.3	5,420*
	120	72.3	7,500*	75.0	6,160*	77.5	5,240*
	130	70.6	7,150*	73.3	5,940*	75.8	5,060*
	140	68.8	6,820*	71.5	5,720*	74.0	4,920*
	150	67.0	6,550*	69.7	5,520*	72.2	4,780*
250' (76.2 m)	160	65.2	6,290*	67.9	5,350*	70.3	4,660*
	170	63.4	6,040*	66.0	5,170*	68.4	4,540*
	180	61.5	5,820*	64.2	5,020*	66.5	4,460*
	190	59.6	5,620*	62.3	4,880*	64.6	4,350*
	200	57.7	5,430*	60.3	4,770*	62.6	4,280*
	210	55.7	5,260*	58.3	4,640*	60.6	4,200*
	220	53.7	5,100*	56.2	4,540*	58.5	4,150*
	230	51.6	4,950*	54.1	4,460*	56.3	4,090*
	240	49.5	4,830*	52.0	4,380*	54.1	4,070*
	250	47.2	4,720*	49.7	4,310*	51.8	4,040*

Boom length	Jib Radius (Feet)	5.0 Deg offset		15.0 Deg offset		25.0 Deg offset	
		Boom Angle	Rating (Pounds)	Boom Angle	Rating (Pounds)	Boom Angle	Rating (Pounds)
	64	82.0	10,210*	-	-	-	-
	70	81.0	9,860*	-	-	-	-
	80	79.4	9,300*	-	-	-	-
	90	77.8	8,790*	80.4	7,000*	-	-
	100	76.1	8,340*	78.8	6,710*	81.3	5,580*
	110	74.5	7,920*	77.1	6,440*	79.6	5,400*
	120	72.8	7,550*	75.4	6,190*	77.9	5,220*
	130	71.1	7,230*	73.7	5,970*	76.2	5,060*
	140	69.4	6,890*	72.0	5,740*	74.5	4,920*
	150	67.7	6,620*	70.3	5,550*	72.7	4,790*
260' (79.2 m)	160	66.0	6,340*	68.6	5,370*	70.9	4,670*
	170	64.2	6,100*	66.8	5,190*	69.1	4,550*
	180	62.4	5,890*	65.0	5,050*	67.3	4,450*
	190	60.6	5,670*	63.1	4,910*	65.4	4,360*
	200	58.7	5,480*	61.2	4,780*	63.5	4,270*
	210	56.8	5,320*	59.3	4,650*	61.5	4,190*
	220	54.9	5,160*	57.4	4,550*	59.5	4,130*
	230	52.9	5,000*	55.3	4,470*	57.5	4,080*
	240	50.8	4,870*	53.3	4,390*	55.4	4,050*
	250	48.7	4,770*	51.1	4,320*	53.2	4,000*
	260	46.5	4,650*	48.9	4,250*	50.9	4,000*



WITH 92HI OFFSET TIP BOOM, 16HL JIB

☰ 195,000 lb + 64,000 lb CB
360°
ANSI B 30.5

100' (30.5 m) Jib length							
Boom length	Jib Radius (Feet)	5.0 Deg offset Boom Angle	5.0 Deg offset Rating (Pounds)	15.0 Deg offset Boom Angle	15.0 Deg offset Rating (Pounds)	25.0 Deg offset Boom Angle	25.0 Deg offset Rating (Pounds)
	66	81.9	10,140*	-	-	-	-
	70	81.2	9,890*	-	-	-	-
	80	79.7	9,360*	-	-	-	-
	90	78.1	8,850*	80.7	7,040*	-	-
	100	76.5	8,390*	79.1	6,710*	81.5	5,570*
	110	74.9	8,000*	77.5	6,470*	79.9	5,390*
	120	73.3	7,630*	75.8	6,210*	78.2	5,210*
	130	71.7	7,290*	74.2	5,960*	76.6	5,060*
	140	70.0	6,940*	72.6	5,760*	74.9	4,910*
	150	68.3	6,660*	70.9	5,570*	73.2	4,770*
270' (82.3 m)	160	66.7	6,380*	69.2	5,380*	71.5	4,640*
	170	65.0	6,170*	67.5	5,220*	69.7	4,530*
	180	63.2	5,920*	65.7	5,050*	68.0	4,440*
	190	61.5	5,710*	63.9	4,910*	66.2	4,350*
	200	59.7	5,540*	62.1	4,800*	64.3	4,270*
	210	57.8	5,340*	60.3	4,660*	62.4	4,180*
	220	56.0	5,180*	58.4	4,580*	60.5	4,120*
	230	54.1	5,050*	56.5	4,480*	58.6	4,060*
	240	52.1	4,920*	54.5	4,400*	56.5	4,030*
	250	50.1	4,790*	52.4	4,320*	54.5	3,980*
	260	48.0	4,700*	50.3	4,250*	52.3	3,970*
	270	45.8	4,580*	48.2	4,200*	50.1	3,960*
	67	81.9	10,110*	-	-	-	-
	70	81.5	9,940*	-	-	-	-
	80	79.9	9,390*	-	-	-	-
	90	78.4	8,930*	80.9	7,010*	-	-
	100	76.9	8,470*	79.4	6,730*	81.8	5,540*
	110	75.3	8,040*	77.8	6,450*	80.2	5,360*
	120	73.7	7,670*	76.2	6,220*	78.6	5,200*
	130	72.2	7,340*	74.6	5,970*	77.0	5,050*
	140	70.6	7,030*	73.0	5,770*	75.3	4,900*
	150	68.9	6,740*	71.4	5,570*	73.7	4,760*
280' (85.3 m)	160	67.3	6,450*	69.8	5,390*	72.0	4,640*
	170	65.7	6,200*	68.1	5,220*	70.3	4,530*
	180	64.0	5,990*	66.4	5,080*	68.6	4,440*
	190	62.3	5,780*	64.7	4,940*	66.9	4,350*
	200	60.6	5,590*	63.0	4,800*	65.1	4,260*
	210	58.8	5,400*	61.2	4,680*	63.3	4,170*
	220	57.0	5,230*	59.4	4,570*	61.5	4,110*
	230	55.2	5,100*	57.5	4,490*	59.6	4,050*
	240	53.3	4,950*	55.6	4,410*	57.6	4,000*
	250	51.3	4,850*	53.7	4,330*	55.6	3,960*
	260	49.4	4,720*	51.7	4,260*	53.6	3,940*
	270	47.3	4,630*	49.6	4,200*	51.5	3,910*
	280	45.2	4,540*	47.4	4,160*	49.3	3,910*

Boom length	Jib Radius (Feet)	5.0 Deg offset Boom Angle	5.0 Deg offset Rating (Pounds)	15.0 Deg offset Boom Angle	15.0 Deg offset Rating (Pounds)	25.0 Deg offset Boom Angle	25.0 Deg offset Rating (Pounds)
	68	82.0	10,090*	-	-	-	-
	70	81.7	9,970*	-	-	-	-
	80	80.2	9,450*	-	-	-	-
	90	78.7	8,970*	81.2	7,010*	-	-
	100	77.2	8,510*	79.7	6,750*	82.0	5,520*
	110	75.7	8,080*	78.1	6,460*	80.4	5,350*
	120	74.2	7,720*	76.6	6,230*	78.9	5,180*
	130	72.6	7,380*	75.1	5,980*	77.3	5,040*
	140	71.1	7,050*	73.5	5,790*	75.7	4,880*
	150	69.5	6,790*	71.9	5,590*	74.1	4,750*
290' (88.4 m)	160	67.9	6,530*	70.3	5,400*	72.5	4,620*
	170	66.3	6,270*	68.7	5,250*	70.9	4,520*
	180	64.7	6,020*	67.1	5,080*	69.2	4,430*
	190	63.1	5,810*	65.4	4,940*	67.5	4,320*
	200	61.4	5,630*	63.7	4,830*	65.8	4,250*
	210	59.7	5,460*	62.0	4,690*	64.1	4,160*
	220	58.0	5,290*	60.3	4,580*	62.3	4,100*
	230	56.2	5,130*	58.5	4,500*	60.5	4,040*
	240	54.4	4,990*	56.7	4,400*	58.6	3,980*
	250	52.5	4,860*	54.8	4,340*	56.7	3,950*
	260	50.6	4,760*	52.9	4,260*	54.8	3,920*
	270	48.7	4,660*	50.9	4,190*	52.8	3,890*
	280	46.6	4,570*	48.9	4,140*	50.7	3,870*
	290	44.6	4,480*	46.7	4,100*	48.5	3,870*

NOTES TO LIFTING CAPACITY

⚠ Warning

This rating chart is invalid if the crane has been modified or altered by use of other than GENUINE AMERICAN PARTS as such modifications or alterations may affect its capacity or safe operation. See American Crane Corporation Service Bulletin #259.

Ratings in this chart are in POUNDS and do not exceed the percentage of tipping specified for this crane by ANSI B30.5. All ratings require that the crane be standing level on a firm uniformly supporting surface.

Do not lift loads in excess of those shown on this chart. Lifting loads in excess of those shown or operation not in accordance with good operating practice, including limitations shown on page 3499 of Operator's Manual, can cause tipping, structural damage or catastrophic failure.

Asterisk (*) areas on this chart indicate ratings which are limited by strength of material or factors other than stability (tipping).

„RADIUS IN FEET“ is the horizontal distance at ground level from the crane centerline of rotation to a vertical line through the center of gravity of the suspended load.

When using the main boom fall with jib in place, the main fall ratings must be reduced by the jib effective weight shown on the jib rating chart plus twice the weight of all suspended blocks, slings, rope, etc., at the jib fall. See Appendix A.

Blocks, slings, buckets and other load carrying devices are considered part of the load. The weight of standard hoisting ropes for the rating at a given radius has been calculated as part of the boom point load and need not be considered in determining net allowable loads. See Appendix A.

Ratings shown on this chart make no allowance for such factors as out of plumb loads, wind, poor soil conditions and dynamic effects due to excessive operating speeds. The user (operator) must exercise judgement to make allowance for these conditions. See page 3499 of Operator's Manual for detailed information.

No account is taken of the wind force on the load. This effect, which can be substantial for loads with large surface areas, must be considered by the user. In any wind it is strongly recommended that taglines be used to control the load.

Combinations of boom or boom and jib with a total length exceeding 350 ft (107 m) can be operated at full rated capacity only in wind speeds of 15 mph (24 km/h) or less. If lifts are to be performed in winds between 15 mph (24 km/h) and 25 mph (40 km/h), ratings must be reduced 10%. No operation of the above combinations should be attempted in wind speeds over 40 km/h (25 mph). The above limitations do not take into account loads with excessive surface area which are not restrained by tag lines.

BOOM HOIST LINE is 18 parts of 7/8 inch diameter 6 x 26, WS, FW, RAL, IWRC, EIPS wire rope with a minimum breaking strength of 79,600 pounds.

BOOM PENDANT SUSPENSION is 4 parts of 1-3/8 inch diameter EEIPS wire rope with a minimum breaking strength of 211,000 pounds.

JIB BACKSTAY LINE is 7/8 inch diameter wire rope with a minimum breaking strength of 69,200 pounds.

JIB FRONTSTAY PENDANT SUSPENSION is 2 parts of 7/8 inch diameter wire rope with a minimum breaking strength of 69,200 pounds.

WHIPLINE is 1-1/8 inch diameter 6 x 25, FW, RRL, IWRC, EEIPS wire rope with a minimum breaking strength of 143,000 pounds.

ERECTION

Erection „BLOCKED OVER THE END“ is with the boom over the idler end with idler tumblers blocked (See operator's manual for blocking instructions). Erection „OVER THE SIDE“ is with the boom 90° to the side frames. Blocks, slings and other load carrying devices must be on the ground during erection.

LOAD HOISTING INFORMATION - 1-1/8 inch diameter EEIPS wire rope			
MAXIMUM LIFTING CAPACITY - LBS.	MINIMUM PARTS OF LINE	MAXIMUM HOISTING DISTANCE - FEET	
		MAIN HOIST	AUX HOIST
32,000	1	1,310	1,310

92HI OFFSET TIP BOOM MAXIMUM BOOM & JIB SELF-ERECTION DATA		
	BOOM LENGTH (FEET)	JIB LENGTH
		16HL JIB (FEET)
BLOCKED OVER THE END	300	50
	290	100
OVER THE SIDE	280	0
	270	70
	260	100

BOOM LENGTH (FEET)	BOOM COMPOSITION CHART - 92HI OFFSET TIP					
	BOOM SECTIONS					
	25' 92HI INNER	15' 92HT CENTER	20' 92HT CENTER	10' 92ST CENTER	50' 92ST CENTER	40' 92H OUTER
100	1	1	1	0	0	1
110	1	1	1	1	0	1
120	1	1	1	2	0	1
130	1	1	0	0	1	1
140	1	1	0	1	1	1
150	1	1	1	0	1	1
160	1	1	1	1	1	1
170	1	1	1	2	1	1
180	1	1	0	0	2	1
190	1	1	0	1	2	1
200	1	1	1	0	2	1
210	1	1	1	1	2	1
220	1	1	1	2	2	1
230	1	1	0	0	3	1
240	1	1	0	1	3	1
250	1	1	1	0	3	1
260	1	1	1	1	3	1
270	1	1	1	2	3	1
280	1	1	0	0	4	1
290	1	1	0	1	4	1

JIB LENGTH (FEET)	16HL JIB COMPOSITION CHART					JIB OFFSET "A" IN FEET		
	20' INNER	10' CENTER	20' CENTER	20' OUTER	EFF. JIB WEIGHT (POUNDS)	5°	15°	25°
	40	1	0	0		1	1,500	4' 10"
50	1	1	0	1	2,050	5' 8"	12' 1"	18' 3"
60	1	0	1	1	2,600	6' 6"	13' 10"	21' 2"
70	1	1	1	1	3,150	7' 1"	15' 10"	24' 4"
80	1	0	2	1	3,700	7' 9"	17' 8"	27' 4"
90	1	1	2	1	4,350	8' 4"	19' 7"	30' 7"
100	1	0	3	1	4,950	9' 0"	21' 4"	33' 6"

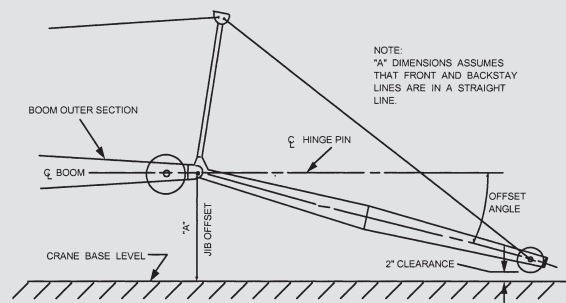

4

TECHNICAL DESCRIPTION**HYDRAULIC CRAWLER CRANE****Maximum lifting capacity**

275 tons (249.5 mt).

300 ft (91.4 m) maximum lift crane boom

- 92HI tubular chord boom, pin connected.
- 65 ft (19.8 m) inner and outer and 10 / 15 / 20 / 50 ft (3 / 4.5 / 6 / 15 m) available inserts provide boom compositions in 10 ft (3 m) increments from 65 ft (19.8 m) to 300 ft (91.4 m).

Robust engine

- Cummins Model QSL9-C diesel engine supplies 325 HP (242 kW) @ 2000 rpm, 542 cu. in. (9 l) displacement, 180 gallons (681 l) fuel capacity.

Environmental operator's cab

- Designed to provide excellent viewing range and quiet, comfortable operation.
- 37 in. (0.91 m) wide cab has wide curved windows on both top and bottom.
- Easy-to-operate modular and ergonomically designed controls reduce operator fatigue and increase productivity.
- Load Moment Indicator with interactive screen features a shockless stop system. Operator can select from three display modes: loaded condition diagram, rated lifting curve, and rated lifting load table.
- Adjustable operator's seat, radio, air conditioner, overhead window, sun visor, fan, overhead and front wipers, and drum rotation indicators standard.

Heavy duty carbody and crawlers

- Fabricated steel carbody is deep box constructed with square axles for the crawler side frames. Precision machined top supports anti-friction swing circle and multiple pass hydraulic swivel joint.
- Crawlers have high alloy steel tumbler yokes and rigid fabricated structures with built-in sealed automatic lubrication system.
- 48" (1219 mm) crawler shoes.
- Travel mechanism is set within shoe width.
- Side frames extended or retracted by cylinders inside the carbody.
- Two travel speed settings – 0.55 / 0.37 mph (0.88 / 0.60 km/h).
- 30 % (17°) gradeability.

Powerful, high-speed hoist system

- Two identical independent main and auxiliary load hoisting drums provide ample lifting power. Drums are grooved for 1-1/8 in. (28 mm) diameter rope. Max. line speed is 540 fpm (165 m/min), max. single line pull is 54,060 lb (24 522 kg). Rated single line pull is 40,850 lb (18 530 kg). Freefall on main and auxiliary drums.
- Each drum, including optional third, has power up/down. Load hoists are further controllable in stepless mode.
- Ample work space in front of drums allows easy access for cable installation and maintenance.
- External contracting brake.
- Internal expanding band clutch.
- Separate caption for swing.
- 1.7 rpm swing speed.

High capacity, dependable hydraulic system

- Open circuit system has 2 variable displacement piston pumps which supply power to the travel and hoisting functions, 3 gear pumps provide power for swing, hydraulic cylinders and pilot pressure.
- Hydraulic reservoir with 90 gallons (341 l) capacity and 10 micron filtration. System capacity is 150 gallons (568 l).
- Component working range is between -4 and 203° F (-20 and 95° C).

Fourteen piece removable counterweight

- 13 piece pin connected counterweight can be assembled or disassembled easily within minutes.
- Hydraulic counterweight removal system is standard and makes the HC 275 one of the most transportable cranes in its class.
- Moves on 11 trucks with 260 ft (79.2 m) boom and 105 ft (32.0 m) of jib. At 11 ft 6 in. (3.51 m) wide and 11 ft 3 in. (3.43 m) high, the basic HC 275 will transport on a standard lowboy trailer.

Options include

- Third drum.
- Single sheave extension.
- Choice of 16HL – 32,000 lb (14 515 kg) or #30 – 60,000 lb (27 216 kg) capacity jib.
- Reeving winch.

TRANSPORT EXAMPLE FOR HC 275

260' 92HI BOOM WITH SIX SHEAVE OFFSET TIP & 105' OF JIB

Loads required as follows: (weights shown do **NOT** include blocking or tie-down material)

LOAD NO. 1	
3 x counterweight overlays @ 11,150 lbs each	33,450 lbs.
1 x 50' boom center section	5,000 lbs.
TOTAL LOAD	38,450 lbs.
LOAD NO. 2	
3 x counterweight overlays @ 11,150 lbs each	33,450 lbs.
1 x 50' boom center section	5,000 lbs.
TOTAL LOAD	38,450 lbs.
LOAD NO. 3	
3 x counterweight overlays @ 11,150 lbs each	33,450 lbs.
1 x 50' boom center section	5,000 lbs.
TOTAL LOAD	38,450 lbs.
LOAD NO. 4	
2 x counterweight overlays @ 11,150 lbs each	22,300 lbs.
40' six sheave outer section	6,660 lbs.
TOTAL LOAD	28,960 lbs.
LOAD NO. 5	
25' boom inner section	6,500 lbs.
Front carbody counterweight	32,000 lbs.
TOTAL LOAD	38,500 lbs.
LOAD NO. 6	
3 x counterweight overlays @ 11,150 lbs each	33,450 lbs.
1 x 20' boom center section	3,550 lbs.
1 x 10' boom center section	1,795 lbs.
1 x 15' boom center section	2,750 lbs.
TOTAL LOAD	41,545 lbs.
LOAD NO. 7	
Base counterweight	39,000 lbs.
TOTAL LOAD	39,000 lbs.
LOAD NO. 8	
Crawler side frame	48,000 lbs.
TOTAL LOAD	48,000 lbs.
LOAD NO. 9	
Crawler side frame	48,000 lbs.
TOTAL LOAD	48,000 lbs.
LOAD NO. 10	
Rear carbody counterweight	32,000 lbs.
12.5' jib inner	965 lbs.
12.5' jib outer	910 lbs.
Jib mast	900 lbs.
2 x 10' jib center sections @ 460 each	920 lbs.
2 x 30' jib center sections @ 1,300 each	2,600 lbs.
Miscellaneous	5,000 lbs.
TOTAL LOAD	43,295 lbs.
LOAD NO. 11	
Upperworks and Carbody	105,000 lbs.

KEY

 Counterweight

CB Central ballast

The information contained in this brochure merely consists of general descriptions and a broad compilation of performance features which might not apply precisely as described under specific application conditions or which may change as a result of further product development. The desired performance features only become binding once expressly agreed in the final contract.

Note: Data published herein is intended as a guide only and shall not be construed to warrant applicability for lifting purposes. Crane operation is subject to the computer charts and operation manual both supplied with the crane.

Subject to change without notice.

01 / 06