

803

Explorer

Wacker Neuson Compact Excavator 803



**WACKER
NEUSON**

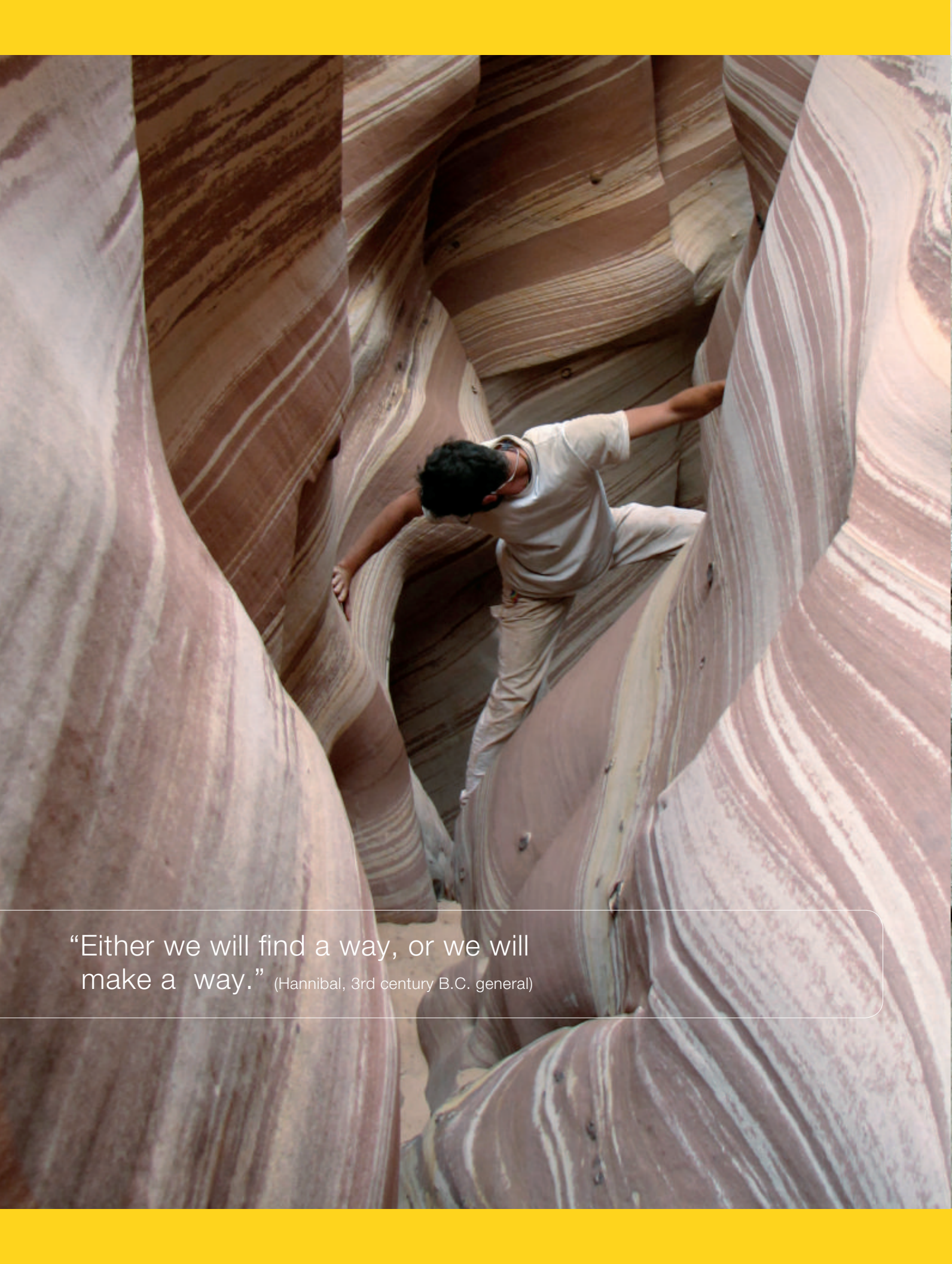

“Either we will find a way, or we will
make a way.” (Hannibal, 3rd century B.C. general)

Small. Extraordinarily powerful. Simply practical.

FOR MANY PEOPLE, THE SMALLEST MACHINE IN THE WACKER NEUSON COMPACT EXCAVATOR RANGE IS SIMPLY THE GREATEST: IT DOES AN INCREDIBLE JOB, ABSOLUTELY WHEREVER IT IS NEEDED, INSIDE OR OUTSIDE.

ALL WACKER NEUSON COMPACT EXCAVATORS ARE SIMPLE TO OPERATE, PROFESSIONAL AND TOUGH, THROUGH AND THROUGH.

Thanks to the special construction of the 803, you can push your way through to areas only a pick and shovel could previously reach, whether indoors or through entrances only as wide as a door or in extremely constricted spaces outdoors, these are all the places where the machine is in its element.

Power supplied by a 3-cylinder diesel engine, hydraulic telescopic chassis and extremely rugged construction make the 803 a machine well-worth discovering in its class.



The 803 is unbeatable,
wherever space and schedules
are exceptionally restricted.



The 700 mm width of the chassis enables it to pass easily through any door, while the extended hydraulic telescopic chassis with an 860 mm external width gives it stability. It can be retracted to a width of 700 mm in no time.

Power, proven technology and protected hydraulics with the lines led through the pivot bracket and inside the stable arm. Perfect protection without a single weak point.

Feel the power and enjoy total control.

The Wacker Neuson 803 “Explorer” is absolutely essential for any rental fleet:

- ease of operation means anyone can start working with it at once.
- the standard one-way auxiliary hydraulic feature allows it to take on jobs with the hammer attachment.

803

- Professional class power and engine output
- Auxiliary hydraulics are a standard feature
- Foldable dozer blade
- Rugged construction



1 The toughest jobs made easy. The Wacker Neuson 803 really comes into its own in places where machines were unable to go previously. The full power of an extremely capable excavator can now get you right in close, virtually anywhere.

2 The width of a door is enough. The telescoping chassis on the 803 has an extra narrow adjustment for special tasks.

3 Excavate right up to the blade and pick up even the smallest parts.

4 Built-in hydraulic safety. The “neck cylinder” arrangement of the hydraulic cylinder gives you the best protection on even the hardest jobs.

5 The folding dozer blade always stays connected to the machine and can never be lost.

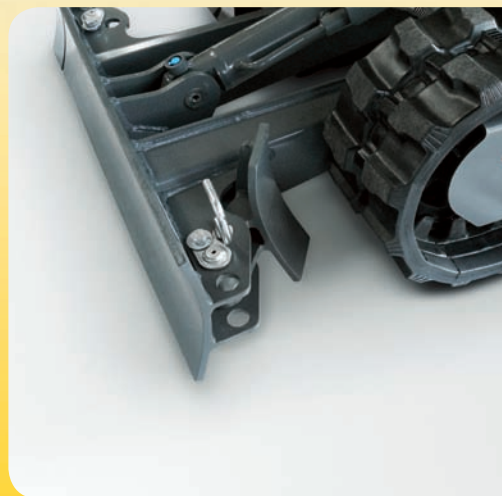

Utilise the new strengths
of our machines and experience
cutting edge power.



From the engine to the hydraulics and down to the controls:
everyday practical challenges faced on the job have now found
their master. A "little giant with truly professional performance".

**The tried and tested 3-cylinder diesel engine is really packed
with energy: Efficient, economic and reliable.**

Thanks to the superior hydraulics and engine power on the 803,
the powerful and perfectly matched Wacker Neuson hydraulic
hammer can be employed.



803



One-way hydraulics are a standard feature. Ideal for operating the specially matched Wacker Neuson hammer.



Easily managed and highly effective – The 803 has all the features of a cult machine.

The 803 is a true favourite with contractors, rental customers and all other users, who can immediately make full use of its enormous potential. The reduction of excessive design on the control panel is a clear indication of this – it could not be more compact and concentrated.

Service and maintenance is reduced to a minimum – simply open the engine cover and all technical components are accessible for service and maintenance work. This saves time and ensures the 803 is back on the job quicker than any other machine.



The broad scope of the 803 – An abundance of profitable areas of operation.

- 1 **New areas of application** open up everywhere, especially where work once could virtually only be carried out with a shovel and pickaxe.
- 2 **Gardens and installations with a only very narrow access points** are the perfect playgrounds for the 803. In these areas, its compact design really allows it to unfold its true potential.



**The simplicity of the 803 is exemplary:
Whether on the job, carrying out maintenance or simply making the
decision to go for this machine.**

The 803 is an intuitive excavator and operating one will immediately become second nature to the user. Its true versatility assures that it remains profitable in the long term. You can get the maximum benefit from it immediately.

**Technical expertise put into action with ease – far more can now be
achieved with the combination of excavating tool and dozer blade.**

Bringing the excavating tool in close enough to the dozer blade on the Wacker Neuson 803 makes picking up stones and other material easily possible.



2



3

3 Getting to grips with the job wherever it is needed and saving time and money in the process: This robust all-rounder from Wacker Neuson is the first choice in gardening and landscaping work.





“The real voyage of discovery is
not to seek out new landscapes,
but to see the world with new eyes.”

(Marcel Proust)

803

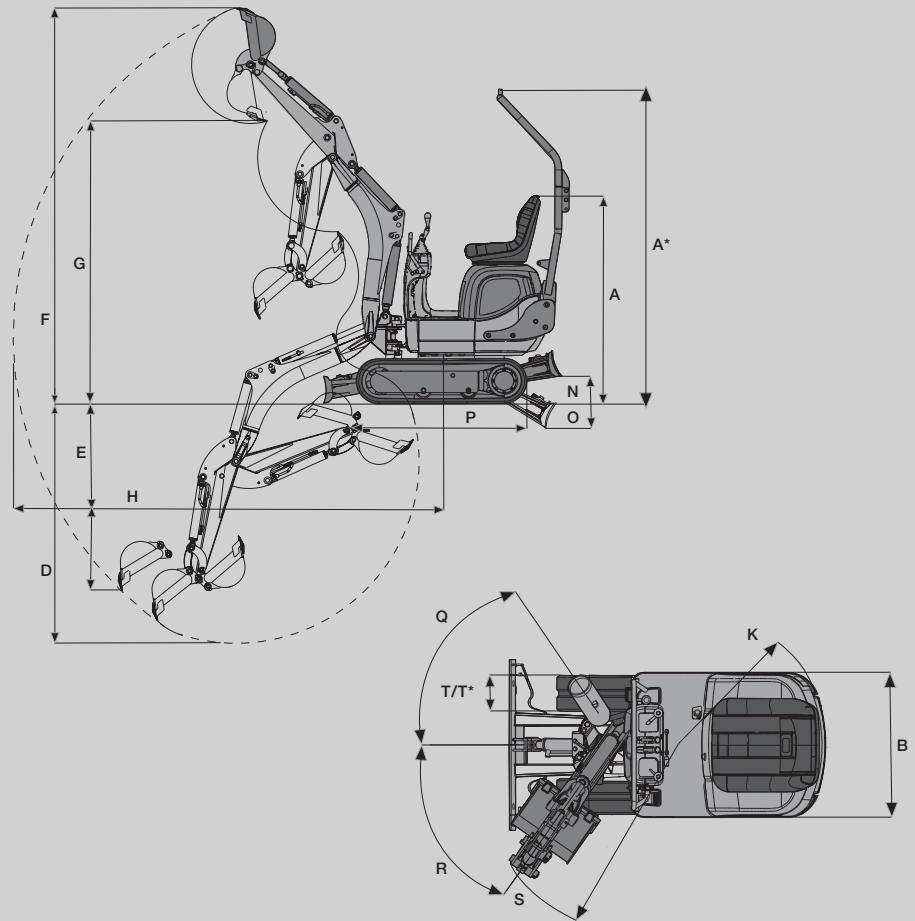

DIMENSIONS

803

A	Height	1507 mm
A*	Height	2276 mm
B	Superstructure width	730 mm
	Running gear width retracted/extended	700/ 860 mm
	Transport length (arm lowered)	2746 mm
D	Max. digging depth	1731 mm
E	Max. vertical cut-in depth	1349 mm
F	Max. cut-in height	2863 mm
G	Max. dumping height	2035 mm
H	Max. excavation radius	3074 mm
	Max. reach on the ground	3028 mm
K	Tail swivel radius	747 mm
	Max. arm backset (from centre bucket right side)	245 mm
	Max. arm backset (from centre bucket left side)	283 mm
N	Max. lifting height (bulldozer blade above plane)	197 mm
O	Max. poking depth (bulldozer blade above plane)	174 mm
P	Running gear length	1220 mm
Q	Max. pivot angle (arm system to right)	56 °
R	Max. pivot angle (arm system to left)	55 °
S	Min. arm pivot radius	1150 mm
T	Track width	180 mm

OPERATIONAL DATA		803
Transport weight		935 kg
Max. arm crowd force		4.5 kN
Max. breakaway force		8.9 kN

ENGINE	
Make/type	Yanmar 3TNV70
Type	Water cooled model 3-cylinder diesel engine
Max. engine output	13.7 kW (18.6 PS)
Balance wheel output ISO	9.6 kW (13 PS)
Capacity	854 cm ³
Rated speed	2100 min ⁻¹
Battery	12 V, 20 Ah
Diesel tank volume	10 l

HYDRAULIC SYSTEM	
Pumps	2 gear pumps
Discharge capacity	11.4 + 11.4 l/min
Operational pressure for the work and travel hydraulics	170 bar
Operational pressure pivot	70 bar
Hydraulic tank contents	14 l

CHASSIS AND SWIVEL GEAR	
Travel speed	1.8 km/h
Gradeability	30°/58%
Track width	180 mm
Number of rollers per side	2
Ground clearance	127 mm
Ground pressure	0.25 kg/cm ²
Superstructure rotation speed	8 min ⁻¹

DOZER BLADE	
Width	700 mm
Height	200 mm
Max. lift above plane	197 mm
Max. lift below plane	174 mm

NOISE EMISSIONS	
Sound power level (LWA) (to 2000/14/EG)	93 dB (A)

LIFT FORCE					
SHORT BUCKET ARM					
	A	2.0 m	2.0 m	2.5 m	2.5 m
B	lengthways	crossways	lengthways	crossways	
1.0 m	242	176	204	125	
0.5 m	272	169	203	122	

A = discharge from hub centre
B = load stop height from ground level

The data (in kg) is without the excavation tools and is ISO 10567 compliant. Lengthways data with dozer blade support. Neither 75% of the static tipping load, nor 87% of the hydraulic lift force are exceeded.

STANDARD EQUIPMENT

803

OPTIONAL FEATURES

803

GENERAL**Rubber track 180 mm****Dozer blade****Working searchlight on lift arm****Toolkit including grease gun and servicing and maintenance handbook****Adjustable driver's seat** with leather-look cover**ENGINE****Water cooled 3-cylinder YANMAR diesel engine****HYDRAULICS****Mechanical controls** with lever operation**ISO compliant valve control****Auxiliary hydraulic connection** for 1 lift arm direction of movement**Hydraulic telescoping chassis** from 700 mm to 860 mm, including dozer blade extension**HYDRAULICS****Double action auxiliary hydraulics****Bucket arm tubing for auxiliary hydraulics****Panolin bio oil****BP-Biohyd SE46****PAINTWORK****Special paint 1 RAL** (for yellow parts only)**Special paint 1 no RAL** (for yellow parts only)**FURTHER ADVANTAGES****ROPS fold-back driver safety shackle****Security 24 (1500 h)** (warranty extension to 24 months or 1500 operational hours)**Security 24 (2000 h)** (warranty extension to 24 months or 2000 operational hours)

Compact construction machines from Wacker Neuson put performance and manoeuvrability first – **wherever and whenever.**

We consider it our constant duty to ensure that we keep our promises regarding our products and services: reliability, confidence, quality, reaction speed, flexibility and innovation.

Wacker Neuson compact construction machines deliver the goods where others simply give up.

Our products convince with their quality, power, intelligent hydraulics, compact dimensions, innovative technology, highest productivity and reliability.

Only Wacker Neuson, your Compact Equipment specialist, can deliver complete solutions that meet all of these demands.

Keep your business one step ahead with added performance. The Wacker Neuson Compact Class is in fact a class of its own. Success is guaranteed – right down the line.



**WACKER
NEUSON**