

Crawler Excavator

R 317
Litronic®

Operating weight: 17,200 - 21,700 kg
Engine output: 90 kW / 122 hp
Backhoe bucket capacity: 0.17 - 0.95 m³



LIEBHERR

R 317

Litronic®

Operating weight: 17,200 - 21,700 kg
Engine output: 90 kW / 122 hp
Backhoe bucket capacity: 0.17 - 0.95 m³



Performance

State-of-the-art technology and high-quality workmanship are the keys to the success of Liebherr crawler excavators. The R 317 Litronic is compact and boasts outstanding stability – the perfect setup for effective operation. The Liebherr Syncron-Comfort system enables the machine to be operated sensitively, so that all work may be carried out efficiently and productively.

Reliability

Experience is vital for innovative solutions. With over 50 years' experience manufacturing hydraulic excavators, Liebherr is constantly developing progressive solutions and setting new standards. Innovations are only taken to series production once they have passed a wide range of tests in rigorous practical applications.

Economy

Every day on construction sites around the world, Liebherr crawler excavators demonstrate their constant availability. Long service intervals and easily accessible components reduce operating costs.

Comfort

All maintenance points on the superstructure are easy to access, enabling servicing work to be carried out quickly and easily. The driver's workplace is designed in accordance with the latest ergonomic know-how.





Stable blade

- Radially-guided blade
- Optimum levelling properties
- Optional ripping edge on blade
- Various blade widths available



Performance

State-of-the-art technology and high-quality workmanship are the keys to the success of Liebherr crawler excavators. The R 317 Litronic is compact and boasts outstanding stability – the perfect setup for effective operation. The Liebherr Synchron-Comfort system enables the machine to be operated sensitively, so that all work may be carried out efficiently and productively.

A stable basis

Stability

The R 317 Litronic is extremely stable on all terrain and, with its optional blade, is suitable for a wide variety of tasks. For different types of application, a range of track pads is available for the crawler excavator's B55L track frame.

Carrier rollers

Two carrier rollers and a track guide are fitted as standard to ensure a long lifespan. The sloping track-frame edges ensure excellent self-cleaning.

Superior load capacities

The undercarriage's large footprint and an optimal centre of gravity ensure high load capacities.

Optimum loading performance

An uncompromising performance

Maximum output and maximum power are available at all times and without restriction, thereby guaranteeing excellent loading efficiency.

High productivity

The Liebherr Litronic system controls the machine precisely, enabling maximum sensitivity and exacting operation in many fields of application.

High bucket-filling factor

The excavation attachments manufactured by Liebherr are designed specifically for high filling factors. The bucket shape affords excellent penetration characteristics and ensures outstanding efficiency.



Litronic

- Increases the performance of the excavator
- Reduces fuel consumption
- Allows maximum sensitivity



Robust undercarriage

- Long lifespan and high stability
- Two carrier rollers and a track guide fitted as standard
- Large track-frame components for a long lifespan. Large B55L track frame



Liebherr key technologies

- Decades of experience in developing, designing and manufacturing components
- Liebherr-built hydraulic pumps, transfer boxes, slewing gears and drives and electronic components
- Component manufacturing centres in Germany and Switzerland use state-of-the-art production processes



Reliability

Experience is vital for innovative solutions. With over 50 years' experience manufacturing hydraulic excavators, Liebherr is constantly developing progressive solutions and setting new standards. Innovations are only taken to series production once they have passed a wide range of tests in rigorous practical applications.

Highest quality

Liebherr components

Components such as the slewing ring, slewing gear drive, hydraulic rams and electronic parts are developed, tested and manufactured by Liebherr exclusively for the company's construction machines. Components, such as the slewing ring and slewing drive for instance, are harmonised with one another during the construction phase, resulting in consistently high quality.

Large hydraulic system

The large system and tank capacity ensures consistently good oil characteristics throughout the entire replacement interval. The hydraulic components are subjected to less stress and thus have a longer lifetime.

Dependable details

Fuel filter

The Liebherr centrifugal fuel filtering system comes as standard and reliably filters out water and dirt particles.

Long lifespan

The large-volume three-chamber exhaust gas system ensures the long lifetime of the exhaust system and of the engine. It furthermore guarantees low noise emissions.

Magnetic rod

The standard magnetic rod in the hydraulics system increases the lifespan of the oil.



Liebherr hydraulic rams

- Optimised sizes for every machine
- High-quality pin rod surface coating
- Special sealing system for rods and rams
- Special sealed bushings for the pin support
- Travel limit damping at both ends of working rams



Clean air

- Intake air is drawn from the cleanest area behind the cab
- 96 % of all dust and water particles is filtered out by primary centrifugal filters
- The result is a long engine lifespan and long filter-replacement intervals



Intelligent cooling

- Thermostatically controlled cooling system – operates as and when required; reduces fuel consumption and noise levels
- Highly durable drive components
- Accelerated warm-up phase and cab temperature control



Economy

Every day on construction sites around the world, Liebherr crawler excavators demonstrate their constant availability. Long service intervals and easily accessible components reduce operating costs.

Low operating costs

Electronic engine-speed sensing control

The efficient transfer of engine power into hydraulic power equals an optimum utilisation of output. This results in a higher working speed and lower fuel consumption.

Diversity of equipment

A hydraulically adjustable jib, an offset boom, a monoblock boom and an offset monoblock boom are available for the R 317 Litronic for different applications.

Future-proof and stable in value

Customised services

Service personnel trained at the manufacturing plants themselves can provide you with customised services. Your direct line to Liebherr is ensured by the full integration of all service support locations in our own Liebherr logistics system. Electronic access to our worldwide spare parts management system means that replacement parts are available 98% of the time, around the clock.

High resale value

Liebherr excavators are built using durable, high-quality materials and first-class workmanship for a long lifespan, thereby ensuring maximum value retention.

Comprehensive range of services

Liebherr offers a range of individually customised services. With replacement components from the ReMan-, ReBuilt- and Repair ranges, Liebherr can provide the ideal solution, to approved manufacturer quality, for every requirement.



Likufix

- Quick coupling system for hydraulic and mechanical special attachments
- All special attachments can be changed from the driver's cab
- Significant time savings compared to manual hydraulic hose connection

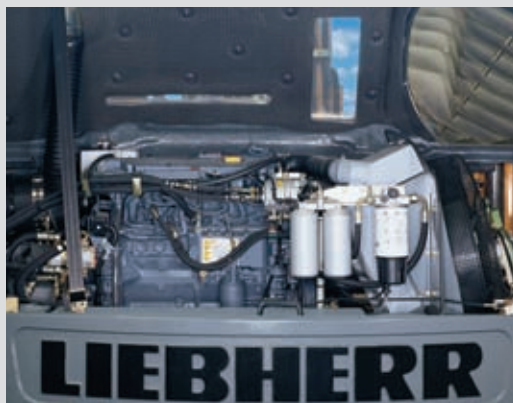

Engine

- Water-cooled diesel engine with direct injection and turbocharger
- Large displacement of 4.8 l
- Engine speed of just 1,800 rpm during travel and operation



Handling – easy and efficient

- Simple, stepless power adjustment via digital control element
- Clear overview of all major machine parameters on the display





Comfort

All maintenance points on the superstructure are easy to access, enabling servicing work to be carried out quickly and easily. The driver's workplace is designed in accordance with the latest ergonomic know-how.

Integrated maintenance solutions

Accessibility

The large engine compartment door enables easy access and safe, comfortable execution of tasks in the engine compartment; all maintenance points are within easy reach.

Maintenance-friendly track frame

Carrier rollers, track rollers and chain-link connecting pins are lubricated for life. The lubrication cylinder of the track tensioning unit is protected to prevent the entry of dirt.

Comfort in the workplace

Large-area cab

Large glass panels and sloping edges ensure optimum visibility over the entire site, guaranteeing relaxed and efficient machine operation.

Plenty of space

Numerous storage options and additional compartments mean that everything has its place.

Pleasant working climate

Low speeds, sophisticated sound-proofing and optimised Liebherr hydraulic components combine to ensure extraordinarily low sound values, comparable with those of a modern diesel car.

A place for everything

- Large open and closed storage trays
- Plenty of storage space outside the cab



Low-maintenance

- Maintenance points easily accessible
- Large engine-compartment lid for accessible servicing

Technical Data



Engine

Rating per ISO 9249	90 kW (122 HP) at 1,800 RPM
Model	Deutz TCD2013 L0V4 according to level IIIA/Tier 3
Type	4 cylinder in-line
Bore/Stroke	108/130 mm
Displacement	4.8 l
Engine operation	4-stroke diesel Common Rail turbo-charged and after-cooler reduced emissions
Harmful emissions values	in accordance with 97/68/EG Stage IIIA
Cooling system	water-cooled and integrated motor oil cooler
Air cleaner	dry-type air cleaner with pre-cleaner and automatic dust discharge (TopAir), main and safety elements
Fuel tank	280 l
Engine idling	sensor controlled
Electrical system	
Voltage	24 V
Batteries	2 x 92 Ah/12 V
Alternator	three phase current 24 V/55 A



Hydraulic System

Hydraulic pump	Liebherr, variable displacement, swash-plate pump
Max. flow	297 l/min.
Max. hydr. pressure	350 bar
Hydraulic pump regulation and control	Liebherr-Synchron-Comfort-system (LSC) with electronic horsepower regulation, pressure cut-off, load sensing and torque controlled swing drive priority
Hydraulic tank capacity	150 l
Hydraulic system capacity	max. 270 l
Filtration	one main return filter with integrated partial micro filtration (5 µm)
Cooling system	compact cooling system comprising cooling unit for water, hydraulic oil and charge air with stepless, thermostatically controlled fan, fan can be folded away for comfortable cleaning of the radiator
Engine speed and output tuning	stepless alignment of engine output and hydraulic power via engine speed variable mode-settings



Hydraulic Controls

Power distribution	via control valve with integrated safety valves, simultaneous and independent operation of travel drive, swing drive and work
Control type	
Attachment and swing	proportional via joystick levers
Travel	proportional via foot pedal
Additional functions	via switch and/or proportional foot pedals
Option	Liebherr-Proportional-Controls, proportionally acting transmitters on the joysticks for additional hydraulic functions



Swing Drive

Drive	Liebherr swashplate motor with torque control and integrated brake valve
Transmission	Liebherr compact planetary reduction gear
Swing ring	Liebherr sealed single race ball bearing swing ring, internal teeth
Swing speed	0 – 9.0 RPM stepless
Swing torque	42 kNm
Holding brake	wet discs (spring applied – pressure released)
Option	pedal controlled positioning brake



Operator's Cab

Cab	largely dimensioned ergonomic cab resiliently mounted, sound insulated, tinted windows, front window stores overhead, door with sliding window, large roof window, sun visor
Operator's seat	shock absorbing suspension, adjustable to operator's weight, 6-way adjustable seat, backward/forward seat adjusting with automatic height adjustment
Joysticks	integrated into adjustable seat consoles
Monitoring	ergonomically arranged, non-glare instrumentation, menu-driven retrieval of current operating conditions via display, automatic monitoring, display, warning (acoustic and visual) and saving of anomalous operating conditions, such as engine overheating and excessively low engine oil pressure or hydraulic oil level
Digital hour meter	visible from outside
Heating system	hot water heat exchanger to provide heated fresh air or circulated air, with additional front window air vents, operating unit in right console
Noise emission	
ISO 6396	L_{pA} (inside cab) = 72 dB(A)
2000/14/EC	L_{WA} (surround noise) = 99 dB(A)
Sound level in correspondence with "Blue Angel" guidelines.	



Undercarriage

Drive	bent axis hydraulic motors on each side of the undercarriage with brake valves actuated on both sides
Transmission	planetary reduction gears
Travel speed	low range – 2.4 km/h high range – 5.0 km/h
Drawbar pull, max.	151 kN
Track components	B60L, maintenance-free
Track rollers/Carrier rollers	Std: 7/2 SL: 9/3 LC: 8/2
Track pads	triple grouser
Chain tensioning	hydraulically
Brakes	wet multi discs (spring applied, pressure released)
Option	blade (Std-Undercarriage)



Attachment

Hydraulic cylinders	Liebherr cylinders with special seal system. Shock absorption
Pivots	sealed, low maintenance
Lubrication	in easily accessible locations

Dimensions

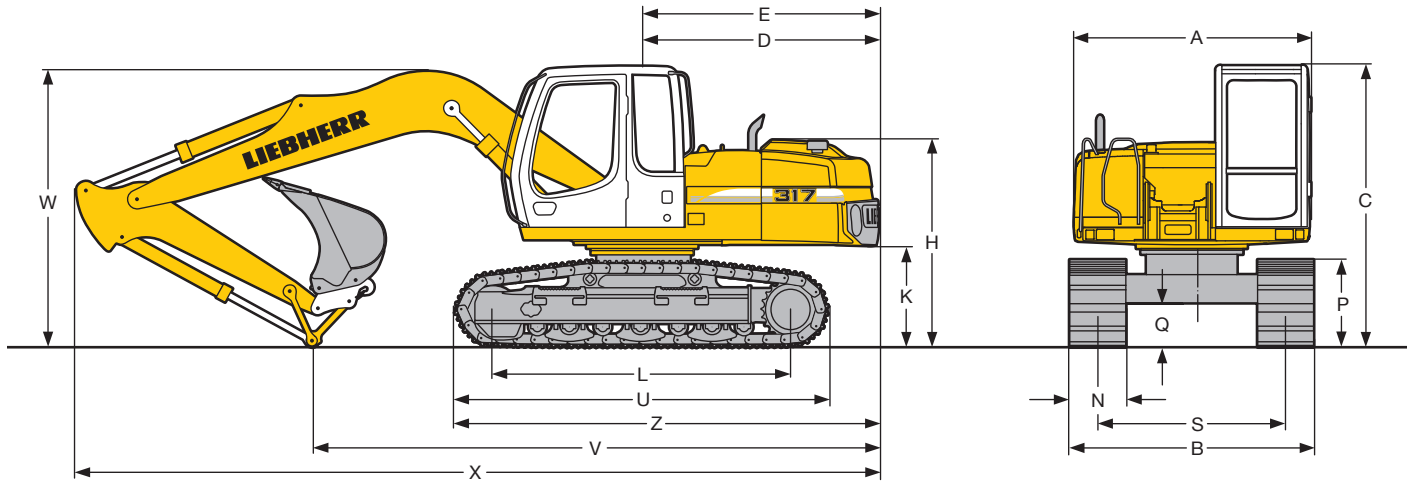

Std-Undercarriage with blade

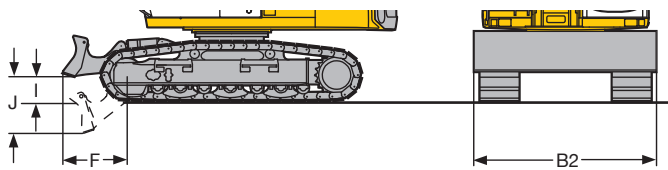

SL-Undercarriage

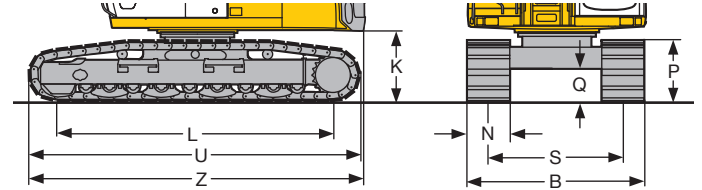

LC-Undercarriage

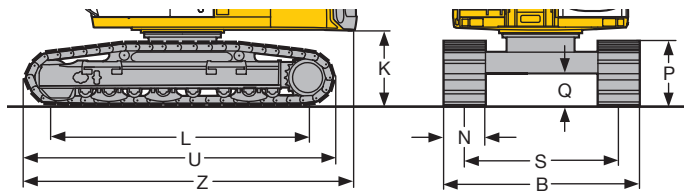

Stick Length	Hydr. Adjustable Boom 3.40 m				Gooseneck Boom 5.00 m				
	Std	with blade	SL	LC	Std	with blade	SL	LC	
m	mm	mm	mm	mm	mm	mm	mm	mm	
V	2.25	6,200	6,200	6,200	6,200	6,050	6,050	6,050	6,050
	2.45	6,000	6,000	6,000	6,000	5,750	5,750	5,750	5,750
	2.65	5,900	5,900	5,900	5,900	5,600	5,650*	5,600	5,600
	3.05	5,400*	5,400	5,400	5,400	5,050	5,100*	5,050	5,050
W	2.25	2,900	2,900	2,900	2,900	3,050	3,050	3,050	3,050
	2.45	2,950	2,950	2,950	2,950	3,050	3,050	3,050	3,050
	2.65	3,000	3,000	3,000	3,000	3,100	3,100*	3,100	3,100
	3.05	3,050*	3,050	3,050	3,050	3,050	3,050*	3,050	3,050
X	2.25	8,700	8,700	8,700	8,700	8,650	8,650	8,650	8,650
	2.45	8,700	8,700	8,700	8,700	8,650	8,650	8,650	8,650
	2.65	8,700	8,700	8,700	8,700	8,700	8,750*	8,700	8,700
	3.05	8,700*	8,700	8,700	8,700	8,700	8,750*	8,700	8,700

	Std	mm	SL	mm	LC	mm
A		2,500		2,500		2,500
B		2,600		2,600		2,850
B2		2,550		-		-
C		2,995		2,995		2,995
D		2,515		2,515		2,515
E		2,515		2,515		2,515
F		990		-		-
H		2,205		2,205		2,205
I		410		-		-
J		935		-		-
K		1,085		1,085		1,085
L		3,170		4,215		3,750
N	500	600	700	600	900	1,000
P		930		930		930
Q		470		470		470
S		2,000		2,000		2,250
U		3,975		5,000		4,555
Z		4,510		5,030		4,800

Stick Length	Adjustable Up/Down Plus Offset Boom 3.60 m				Adjustable Offset Boom 4.90 m			
	Std	with blade	SL	LC	Std	with blade	SL	LC
m	mm	mm	mm	mm	mm	mm	mm	mm
V	2.25	6,450	6,450	6,450	6,450	6,400	6,400	6,400
	2.45	6,250	6,250	6,250	6,250	5,850	5,900*	5,850
	2.65	6,150	6,150	6,150	6,150	5,500	5,600*	5,500
	3.05	5,650	5,700*	5,650	5,650	4,750	4,800*	5,000
W	2.25	3,000	3,000	3,000	3,000	3,050	3,050	3,050
	2.45	3,000	3,000	3,050	3,000	3,000	3,000*	3,000
	2.65	3,100	3,100	3,100	3,100	3,000	3,000*	3,000
	3.05	3,100	3,100*	3,150	3,100	2,700	2,700*	2,950
X	2.25	8,900	8,900	8,850	8,900	8,550	8,550	8,550
	2.45	8,900	8,900	8,900	8,900	8,600	8,650*	8,600
	2.65	8,850	8,850	8,900	8,850	8,550	8,650*	8,550
	3.05	8,900	8,950*	8,900	8,900	8,550	8,600*	8,600

E = Tail radius

* Attachment over digging axle

Backhoe Attachment

with Hydr. Adjustable Boom 3.40 m

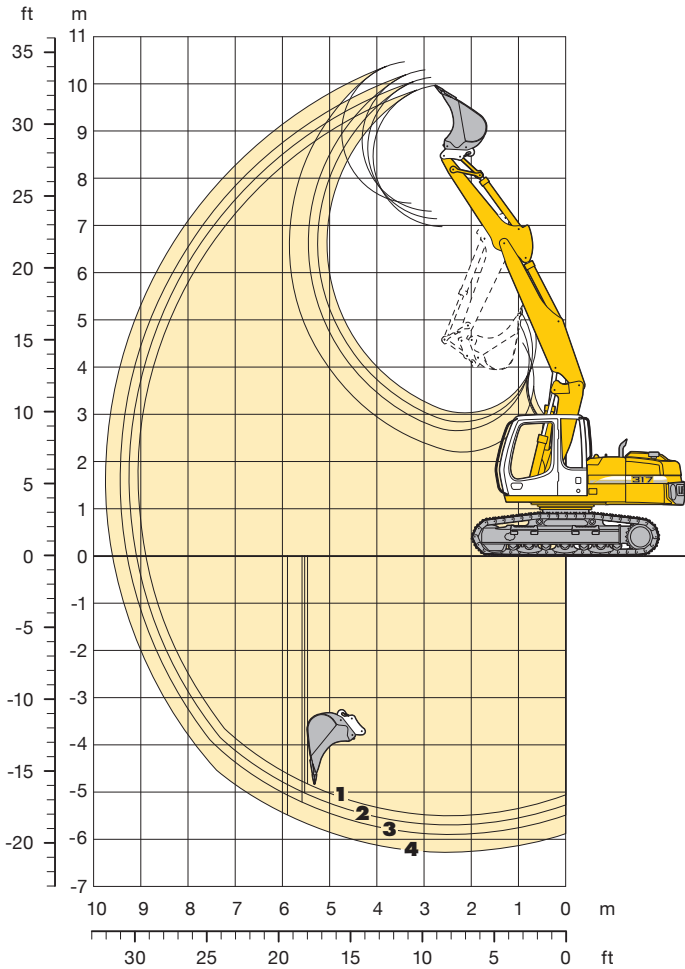

Digging Envelope with Quick Change Adapter

		1	2	3	4
Stick length	m	2.25	2.45	2.65	3.05
Max. digging depth	m	5.50	5.70	5.90	6.25
Max. reach at ground level	m	8.90	9.10	9.30	9.60
Max. dumping height	m	7.00	7.15	7.30	7.45
Max. teeth height	m	9.95	10.15	10.30	10.45
Min. attachment radius	m	2.70	2.80	2.85	2.70

Digging Forces without Quick Change Adapter

		1	2	3	4
Max. digging force (ISO 6015)	kN	81.0	76.0	71.6	64.2
	t	8.3	7.7	7.3	6.5
Max. breakout force (ISO 6015)	kN	98.4	98.4	98.4	98.4
	t	10.0	10.0	10.0	10.0

Max. breakout force with ripper bucket 125.7 kN (12.8 t)
 Max. possible digging force (stick 1.70 m) 99.4 kN (10.1 t)

Operating Weight and Ground Pressure

The operating weight includes basic machine with triple grouser pads, hydr. adjustable boom 3.40 m, stick 2.25 m, quick change adapter 33 and bucket 1,050 mm/0.80 m³.

Undercarriage versions		Std			Std with blade		
Pad width	mm	500	600	700	500	600	700
Weight	kg	17,600	17,900	18,100	19,200	19,500	19,700
Ground pressure	kg/cm ²	0.51	0.43	0.38	0.56	0.47	0.41

Undercarriage versions		SL			LC		
Pad width	mm	600	900	1000	500	600	700
Weight	kg	19,400	20,700	21,000	18,600	18,900	19,000
Ground pressure	kg/cm ²	0.36	0.26	0.23	0.46	0.39	0.34

Buckets Machine stability per ISO 10567* (75% of tipping capacity)

Cutting width mm	Capacity ISO 7451 ¹⁾ m ³	Weight kg	Std				Std with stabilizer blade down				SL				LC			
			Stick length (m)				Stick length (m)				Stick length (m)				Stick length (m)			
			2.25	2.45	2.65	3.05	2.25	2.45	2.65	3.05	2.25	2.45	2.65	3.05	2.25	2.45	2.65	3.05
300 ²⁾	0.17	220	□	□	□	□	□	□	□	□	□	□	□	□	□	□	□	
400 ²⁾	0.24	250	□	□	□	□	□	□	□	□	□	□	□	□	□	□	□	
500 ²⁾	0.30	290	□	□	□	□	□	□	□	□	□	□	□	□	□	□	□	
650 ²⁾	0.45	350	□	□	□	□	□	□	□	□	□	□	□	□	□	□	□	
850 ²⁾	0.60	400	□	□	□	□	□	□	□	□	□	□	□	□	□	□	□	
1,050 ²⁾	0.80	480	□	□	□	△	□	□	□	□	□	□	△	□	□	□	△	
1,250 ²⁾	0.95	520	□	△	△	■	□	△	△	■	□	△	△	■	□	△	△	■
300 ³⁾	0.18	210	□	□	□	□	□	□	□	□	□	□	□	□	□	□	□	
400 ³⁾	0.26	240	□	□	□	□	□	□	□	□	□	□	□	□	□	□	□	
500 ³⁾	0.32	270	□	□	□	□	□	□	□	□	□	□	□	□	□	□	□	
650 ³⁾	0.45	330	□	□	□	□	□	□	□	□	□	□	□	□	□	□	□	
850 ³⁾	0.65	380	□	□	□	□	□	□	□	□	□	□	□	□	□	□	□	
1,050 ³⁾	0.85	460	□	□	□	△	□	□	□	□	□	□	△	□	□	□	△	
1,250 ³⁾	1.05	500	□	△	■	■	□	△	■	■	□	△	■	■	□	△	■	■

* Indicated loads are based on ISO 10567 and do not exceed 75% of tipping or 87% of hydraulic capacity, max. stick length without quick change adapter, lifted 360° on firm

¹⁾ comparable with SAE (heaped)

²⁾ Bucket with teeth (also available in HD-version) ³⁾ Bucket with cutting lip (also available in HD-version)

Buckets up to 400 mm cutting width with limited digging depth

Max. material weight □ = ≤ 1.8 t/m³, △ = ≤ 1.5 t/m³, ■ = ≤ 1.2 t/m³, ▲ = not authorized

Lift Capacities

with Hydr. Adjustable Boom 3.40 m

Stick 2.25 m

m	Undercarriage	3.0 m		4.5 m		6.0 m		7.5 m		m
		Std	Stabilizer blade down	Std	Stabilizer blade down	Std	Stabilizer blade down	Std	Stabilizer blade down	
9.0	Std, Stabilizer blade down SL LC									
7.5	Std, Stabilizer blade down SL LC			3.6* 3.6*				2.5* 2.5*		4.93
6.0	Std, Stabilizer blade down SL LC			4.7* 4.7*	3.3 3.4*			2.2* 2.2*		6.37
4.5	Std, Stabilizer blade down SL LC	5.9* 5.9*	5.9* 5.9*	5.1 5.7*	3.3 4.8*			2.1* 2.1*		7.21
3.0	Std, Stabilizer blade down SL LC	8.9 10.6*	5.0 6.7*	3.7 5.2*	2.5 2.9*	2.1 2.1*		2.1* 2.1*		7.65
1.5	Std, Stabilizer blade down SL LC	8.7 10.9*	4.9* 7.4*	3.2 4.9	2.1 3.4	2.0 2.3*		2.1* 2.1*		7.77
0	Std, Stabilizer blade down SL LC	8.8 12.1*	4.8 7.4	3.0 4.8	2.0 3.2*	2.0 2.6*		2.1* 2.1*		7.57
-1.5	Std, Stabilizer blade down SL LC	8.4 12.7*	4.6 7.6	2.8 4.7	2.2 3.2*	2.2 3.2*		2.1* 2.1*		7.05
-3.0	Std, Stabilizer blade down SL LC	8.2 12.9*	4.3 7.3	2.8 3.7*	2.7 3.2*	2.7 3.2*		2.1* 2.1*		6.10
-4.5	Std, Stabilizer blade down SL LC	9.6 13.0*	5.0 7.5*	3.2 3.8*	2.9 3.4*	2.9 3.4*		3.3 3.4*		

Stick 2.45 m

m	Undercarriage	3.0 m		4.5 m		6.0 m		7.5 m		m
		Std	Stabilizer blade down	Std	Stabilizer blade down	Std	Stabilizer blade down	Std	Stabilizer blade down	
9.0	Std, Stabilizer blade down SL LC									
7.5	Std, Stabilizer blade down SL LC			3.7* 3.7*				2.3* 2.3*		5.24
6.0	Std, Stabilizer blade down SL LC			4.4* 4.4*	3.3 3.5*			2.0* 2.0*		6.61
4.5	Std, Stabilizer blade down SL LC			5.1* 5.3*	3.3 4.7*			1.9* 1.9*		7.42
3.0	Std, Stabilizer blade down SL LC	8.9 10.2*	5.0 6.6*	3.3 4.9	2.2 3.4*	1.9* 1.9*		2.1* 2.1*		7.85
1.5	Std, Stabilizer blade down SL LC	8.7 10.9*	4.8* 7.3	3.2 4.9	2.1 3.4	1.9 2.1*		2.1* 2.1*		7.96
0	Std, Stabilizer blade down SL LC	8.7 11.8*	4.8 7.3*	3.1 4.8	2.0 3.3	1.9 2.3*		2.1* 2.1*		7.77
-1.5	Std, Stabilizer blade down SL LC	8.4 12.6*	4.6 7.5*	2.9 4.7	2.1 2.8*	2.1 2.8*		2.1* 2.1*		7.26
-3.0	Std, Stabilizer blade down SL LC	8.3 13.1*	4.3 7.3	2.7 4.3*	2.5 3.4*	2.5 3.4*		2.1* 2.1*		6.35
-4.5	Std, Stabilizer blade down SL LC	9.7 13.1*	5.0 7.8*	3.2 4.3*	2.9 3.4*	2.9 3.4*		3.1 3.4*		

Stick 2.65 m

m	Undercarriage	3.0 m		4.5 m		6.0 m		7.5 m		m
		Std	Stabilizer blade down	Std	Stabilizer blade down	Std	Stabilizer blade down	Std	Stabilizer blade down	
9.0	Std, Stabilizer blade down SL LC									
7.5	Std, Stabilizer blade down SL LC			3.6* 3.6*				2.1* 2.1*		5.54
6.0	Std, Stabilizer blade down SL LC			4.1* 4.1*	3.3 3.5*			1.8* 1.8*		6.85
4.5	Std, Stabilizer blade down SL LC			4.8* 4.8*	3.4 4.4*	2.2 2.2*		1.8* 1.8*		7.63
3.0	Std, Stabilizer blade down SL LC	9.0 9.7*	5.0 6.4*	3.4 4.9*	2.2 3.5	1.8* 1.8*		1.8* 1.8*		8.05
1.5	Std, Stabilizer blade down SL LC	8.6 10.9*	4.8 7.3	3.3 4.9	2.1 3.4	1.8 1.9*		1.9* 1.9*		8.16
0	Std, Stabilizer blade down SL LC	8.7 11.7*	4.9 7.3*	3.1 4.9	2.1 3.3	1.8 2.1*		2.1* 2.1*		7.98
-1.5	Std, Stabilizer blade down SL LC	8.5 12.5*	4.6 7.5	2.9 4.7	2.0 2.5*	2.0 2.5*		2.1* 2.1*		7.48
-3.0	Std, Stabilizer blade down SL LC	8.3 13.0*	4.3 7.3	2.8 4.6	2.4 3.4*	2.4 3.4*		2.1* 2.1*		6.59
-4.5	Std, Stabilizer blade down SL LC	9.2* 9.2*	5.0 7.9*	3.2 4.8*	2.5 3.4*	2.5 3.4*		3.0* 3.0*		4.02

Stick 3.05 m

m	Undercarriage	3.0 m		4.5 m		6.0 m		7.5 m		m
		Std	Stabilizer blade down	Std	Stabilizer blade down	Std	Stabilizer blade down	Std	Stabilizer blade down	
9.0	Std, Stabilizer blade down SL LC									
7.5	Std, Stabilizer blade down SL LC							1.7* 1.7*		5.95
6.0	Std, Stabilizer blade down SL LC					3.2* 3.2*		1.5* 1.5*		7.18
4.5	Std, Stabilizer blade down SL LC			4.1* 4.1*	3.4 3.9*	3.2* 3.2*		1.5* 1.5*		7.93
3.0	Std, Stabilizer blade down SL LC	8.8* 8.8*	5.0 6.0*	3.3 4.8*	2.2 3.5*	1.5* 1.5*		1.5* 1.5*		8.33
1.5	Std, Stabilizer blade down SL LC	8.7 11.1*	4.8 7.1*	3.3 4.8*	2.2 3.4	1.6* 1.6*		1.6* 1.6*		8.43
0	Std, Stabilizer blade down SL LC	8.6 11.5*	4.8 7.2	3.1 4.8	2.1 3.3	1.7 1.8*		1.8* 1.8*		8.26
-1.5	Std, Stabilizer blade down SL LC	8.5 12.4*	4.6 7.3	2.9 4.7	2.0 3.2	1.8 2.2*		1.8* 1.8*		7.78
-3.0	Std, Stabilizer blade down SL LC	8.2 12.7*	4.3 7.3	2.7 4.5	2.2 3.0*	2.2 3.0*		1.8* 1.8*		6.94
-4.5	Std, Stabilizer blade down SL LC	9.3 10.8*	4.8 5.7*	3.4 5.6*	2.5 3.9*	2.5 3.9*		3.4 4.0*		5.10

Height Can be slewed through 360° In longitudinal position of undercarriage Max. reach * Limited by hydr. capacity

The lift capacities on the load hook of the Liebherr quick-change adapter 33 without grab attachment are stated in metric tons (t) and are valid on a firm, level supporting surface. These capacities can be slewed through 360° with the undercarriage in the transverse position. Capacities in the longitudinal position of the undercarriage (+/- 15°) are specified over the stabilisers with the stabilisers down. The values apply to track pads measuring 600 mm in width when the adjusting cylinder is in the optimal position. Indicated loads comply with the ISO 10567 standard and do not exceed 75% of tipping or 87% of hydraulic capacity, or are limited by the permissible load of the load hook on the quick-change adapter (max. 5 t). Without the quick-change adapter, lift capacities will increase by up to 110 kg.

In accordance with the harmonised EU Standard EN 474-5, hydraulic excavators used for lifting operations must be equipped with pipe rupture protection devices on the hoist cylinders and an overload warning device.

Backhoe Attachment

with Gooseneck Boom 5.00 m

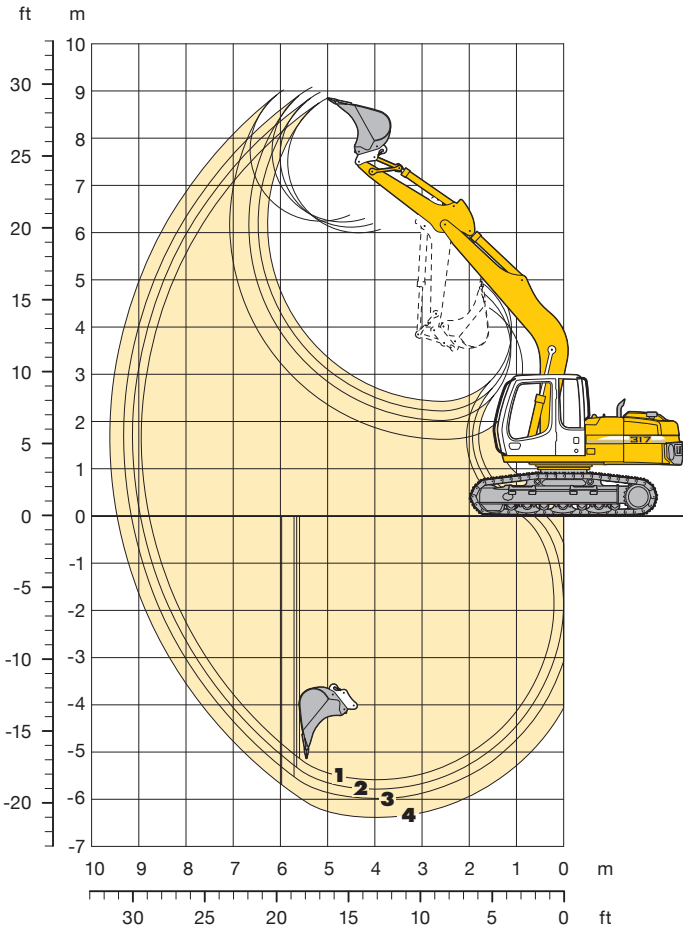

Digging Envelope with Quick Change Adapter

		1	2	3	4
Stick length	m	2.25	2.45	2.65	3.05
Max. digging depth	m	5.60	5.80	6.00	6.40
Max. reach at ground level	m	8.80	9.00	9.20	9.50
Max. dumping height	m	6.05	6.20	6.30	6.35
Max. teeth height	m	8.85	8.95	9.10	9.00
Min. attachment radius	m	3.25	3.10	3.10	2.85

Digging Forces without Quick Change Adapter

		1	2	3	4
Max. digging force (ISO 6015)	kN	81.0	76.0	71.6	64.2
	t	8.3	7.7	7.3	6.5
Max. breakout force (ISO 6015)	kN	98.4	98.4	98.4	98.4
	t	10.0	10.0	10.0	10.0

Max. breakout force with ripper bucket 125.7 kN (12.8 t)
 Max. possible digging force (stick 1.70 m) 99.4 kN (10.1 t)

Operating Weight and Ground Pressure

The operating weight includes basic machine with triple grouser pads, gooseneck boom 5.00 m, stick 2.25 m, quick change adapter 33 and bucket 1,050 mm/0.80 m³.

Undercarriage versions		Std			Std with blade		
Pad width	mm	500	600	700	500	600	700
Weight	kg	17,200	17,500	17,700	18,800	19,100	19,300
Ground pressure	kg/cm ²	0.50	0.42	0.37	0.55	0.46	0.40

Undercarriage versions		SL			LC		
Pad width	mm	600	900	1000	500	600	700
Weight	kg	18,900	20,300	20,600	18,200	18,500	18,600
Ground pressure	kg/cm ²	0.35	0.25	0.23	0.45	0.38	0.33

Buckets Machine stability per ISO 10567* (75% of tipping capacity)

Cutting width mm	Capacity ISO 7451 ¹⁾ m ³	Weight kg	Std				Std with stabilizer blade down				SL				LC			
			Stick length (m)				Stick length (m)				Stick length (m)				Stick length (m)			
			2.25	2.45	2.65	3.05	2.25	2.45	2.65	3.05	2.25	2.45	2.65	3.05	2.25	2.45	2.65	3.05
300 ²⁾	0.17	220	□	□	□	□	□	□	□	□	□	□	□	□	□	□	□	□
400 ²⁾	0.24	250	□	□	□	□	□	□	□	□	□	□	□	□	□	□	□	□
500 ²⁾	0.30	290	□	□	□	□	□	□	□	□	□	□	□	□	□	□	□	□
650 ²⁾	0.45	350	□	□	□	□	□	□	□	□	□	□	□	□	□	□	□	□
850 ²⁾	0.60	400	□	□	□	□	□	□	□	□	□	□	□	□	□	□	□	□
1,050 ²⁾	0.80	480	□	□	□	△	□	□	□	△	□	□	□	△	□	□	□	△
1,250 ²⁾	0.95	520	□	□	△	■	□	□	△	■	□	□	△	■	□	□	△	■
300 ³⁾	0.18	210	□	□	□	□	□	□	□	□	□	□	□	□	□	□	□	□
400 ³⁾	0.26	240	□	□	□	□	□	□	□	□	□	□	□	□	□	□	□	□
500 ³⁾	0.32	270	□	□	□	□	□	□	□	□	□	□	□	□	□	□	□	□
650 ³⁾	0.45	330	□	□	□	□	□	□	□	□	□	□	□	□	□	□	□	□
850 ³⁾	0.65	380	□	□	□	□	□	□	□	□	□	□	□	□	□	□	□	□
1,050 ³⁾	0.85	460	□	□	□	△	□	□	□	△	□	□	□	△	□	□	□	△
1,250 ³⁾	1.05	500	□	△	■	■	□	△	■	■	□	△	■	■	□	△	■	■

* Indicated loads are based on ISO 10567 and do not exceed 75% of tipping or 87% of hydraulic capacity, max. stick length without quick change adapter, lifted 360° on firm

¹⁾ comparable with SAE (heaped)

²⁾ Bucket with teeth (also available in HD-version) ³⁾ Bucket with cutting lip (also available in HD-version)

Buckets up to 400 mm cutting width with limited digging depth

Max. material weight □ = ≤ 1.8 t/m³, △ = ≤ 1.5 t/m³, ■ = ≤ 1.2 t/m³, ▲ = not authorized

Lift Capacities

with Gooseneck Boom 5.00 m

Stick 2.25 m

m	Undercarriage	3.0 m		4.5 m		6.0 m		7.5 m		m
		Std	LC	Std	LC	Std	LC	Std	LC	
9.0	Std, Stabilizer blade down SL LC									
7.5	Std, Stabilizer blade down SL LC									
6.0	Std, Stabilizer blade down SL LC					2.8* 2.8*	2.8* 2.8*	2.2* 2.2*	2.2* 2.2*	6.20
4.5	Std, Stabilizer blade down SL LC					3.2 4.0*	3.7 4.0*	2.1* 2.1*	2.1* 2.1*	7.06
3.0	Std, Stabilizer blade down SL LC	8.6 8.7*	8.6* 8.6*	4.7 5.5*	5.4 5.5*	3.1 4.5*	3.5 4.5*	2.2 2.2*	2.1 2.2*	7.51
1.5	Std, Stabilizer blade down SL LC			4.3 6.9*	5.0 6.9*	2.9 4.7*	3.4 5.1*	2.1 3.1*	2.0 2.3*	7.63
0	Std, Stabilizer blade down SL LC	5.8* 5.8*	5.8* 5.8*	4.1 7.0	4.8 7.6*	2.8 4.5	3.2 5.5*	2.1 2.7*	2.4 2.7*	7.44
-1.5	Std, Stabilizer blade down SL LC	7.4 9.0*	7.4 9.0*	4.0 6.9	4.7 7.7*	2.7 4.5	3.2 5.6*	2.3 3.4*	2.6 3.4*	6.90
-3.0	Std, Stabilizer blade down SL LC	8.9 10.2*	8.2 10.1*	4.1 6.9*	4.7 6.9*	2.8 4.6	3.3 4.9*	2.8 4.6	3.3 4.9*	5.92
-4.5	Std, Stabilizer blade down SL LC	9.5 10.1*	9.5 10.1*	5.0 6.9*	5.0 6.9*			3.4 4.9*		

Stick 2.45 m

m	Undercarriage	3.0 m		4.5 m		6.0 m		7.5 m		m
		Std	LC	Std	LC	Std	LC	Std	LC	
9.0	Std, Stabilizer blade down SL LC									
7.5	Std, Stabilizer blade down SL LC									
6.0	Std, Stabilizer blade down SL LC					3.1* 3.1*	3.1* 3.1*	2.0* 2.0*	2.0* 2.0*	6.44
4.5	Std, Stabilizer blade down SL LC					3.2 3.8*	3.7 3.8*	1.9* 1.9*	1.9* 1.9*	7.27
3.0	Std, Stabilizer blade down SL LC	8.0* 8.0*	8.0* 8.0*	4.7 5.3*	5.0 5.3*	3.1 4.3*	3.3 4.3*	2.2 2.8*	2.0* 2.0*	7.71
1.5	Std, Stabilizer blade down SL LC	5.4* 5.4*	5.4* 5.4*	4.3 6.7*	5.0 6.7*	2.9 4.7*	3.1 5.0*	2.1 3.3	1.9 2.1*	7.82
0	Std, Stabilizer blade down SL LC	5.9* 5.9*	5.9* 5.9*	4.1 7.0	4.7 7.5*	2.7 4.5	3.2 5.4*	2.0 3.3	2.4 3.7*	7.63
-1.5	Std, Stabilizer blade down SL LC	7.3 8.6*	8.5* 8.5*	4.0 6.9	4.7 7.7*	2.7 4.4	3.1 5.6*	2.1 3.0*	2.5 3.0*	7.11
-3.0	Std, Stabilizer blade down SL LC	8.8 10.4*	8.1 10.4*	4.0 6.9	4.7 7.1*	2.7 4.5	3.2 5.0*	2.6 4.3	3.1 4.4*	6.17
-4.5	Std, Stabilizer blade down SL LC	9.4 10.4*	9.4 10.4*	4.9 5.1*	4.9 5.1*	4.2 5.0*	4.6 5.0*	4.2 4.9*	4.8 4.9*	4.53

Stick 2.65 m

m	Undercarriage	3.0 m		4.5 m		6.0 m		7.5 m		m
		Std	LC	Std	LC	Std	LC	Std	LC	
9.0	Std, Stabilizer blade down SL LC							2.0* 2.0*	2.0* 2.0*	
7.5	Std, Stabilizer blade down SL LC							2.0* 2.0*	2.0* 2.0*	5.32
6.0	Std, Stabilizer blade down SL LC					3.2* 3.2*	3.2* 3.2*	1.8* 1.8*	1.8* 1.8*	6.68
4.5	Std, Stabilizer blade down SL LC					3.2 3.7*	3.6* 3.6*	1.8* 1.8*	1.8* 1.8*	7.48
3.0	Std, Stabilizer blade down SL LC	7.5* 7.5*	7.4* 7.4*	4.8 5.1*	5.1* 5.1*	3.1 4.2*	3.6 4.2*	2.2 3.2*	1.8* 1.8*	7.90
1.5	Std, Stabilizer blade down SL LC	6.3* 6.3*	6.3* 6.3*	4.4 6.5*	5.1 6.5*	2.9 4.7*	3.4 4.9*	1.9 1.9*	1.9* 1.9*	8.02
0	Std, Stabilizer blade down SL LC	6.0* 6.0*	6.0* 6.0*	4.1 7.0	4.8 7.5*	2.8 4.5	3.2 5.4*	1.9 2.2*	2.2 2.2*	7.83
-1.5	Std, Stabilizer blade down SL LC	7.3 8.3*	8.2* 8.2*	4.0 6.9	4.7 7.7*	2.7 4.5	3.1 5.6*	2.1 2.7*	2.4 2.7*	7.32
-3.0	Std, Stabilizer blade down SL LC	7.4 10.7*	8.0 10.7*	4.0 6.9	4.7 7.2*	2.7 4.5	3.2 5.2*	2.5 3.8*	2.9 3.8*	6.42
-4.5	Std, Stabilizer blade down SL LC	8.2* 8.1*	8.1* 8.1*	4.2 5.4*	4.5 5.4*	4.3 4.8*	4.1 4.8*	3.7 4.8*	4.3 4.8*	4.87

Stick 3.05 m

m	Undercarriage	3.0 m		4.5 m		6.0 m		7.5 m		m
		Std	LC	Std	LC	Std	LC	Std	LC	
9.0	Std, Stabilizer blade down SL LC									
7.5	Std, Stabilizer blade down SL LC							1.7* 1.7*	1.7* 1.7*	5.72
6.0	Std, Stabilizer blade down SL LC					3.0* 3.0*	3.0* 3.0*	1.5* 1.5*	1.5* 1.5*	6.99
4.5	Std, Stabilizer blade down SL LC					3.3 3.3*	3.3* 3.3*	1.5* 1.5*	1.5* 1.5*	7.76
3.0	Std, Stabilizer blade down SL LC			4.6* 4.6*	4.6* 4.6*	3.1 3.9*	3.3 3.9*	1.5* 1.5*	1.5* 1.5*	8.17
1.5	Std, Stabilizer blade down SL LC	7.9 9.7*	8.5 9.7*	4.4 6.1*	5.1 6.1*	2.9 4.6*	3.5 4.6*	2.1 3.4	1.7* 1.7*	8.28
0	Std, Stabilizer blade down SL LC	6.8* 6.8*	6.8* 6.8*	4.1 7.0	4.8 7.2*	2.7 4.5	3.2 5.2*	2.0 3.3	1.8 1.9*	8.10
-1.5	Std, Stabilizer blade down SL LC	7.2 8.2*	8.2* 8.2*	3.9 6.8	4.6 7.6*	2.6 4.4	3.2 5.5*	2.0 2.9*	1.9 2.3*	7.61
-3.0	Std, Stabilizer blade down SL LC	7.3 11.0*	8.6 10.9*	3.9 6.8	4.6 7.3*	2.6 4.4	3.1 5.3*	2.3 3.3*	2.7 3.3*	6.74
-4.5	Std, Stabilizer blade down SL LC	7.5 9.0*	8.8 9.0*	4.0 6.0*	4.7 6.1*	3.2 5.3*	3.5 4.9*	2.8 4.9*	3.7 4.9*	5.30

Height Can be slewed through 360° In longitudinal position of undercarriage Max. reach * Limited by hydr. capacity

The lift capacities on the load hook of the Liebherr quick-change adapter 33 without grab attachment are stated in metric tons (t) and are valid on a firm, level supporting surface. These capacities can be slewed through 360° with the undercarriage in the transverse position. Capacities in the longitudinal position of the undercarriage (+/- 15°) are specified over the stabilisers with the stabilisers down. The values apply to track pads measuring 600 mm in width. Indicated loads comply with the ISO 10567 standard and do not exceed 75 % of tipping or 87 % of hydraulic capacity, or are limited by the permissible load of the load hook on the quick-change adapter (max. 5 t). Without the quick-change adapter, lift capacities will increase by up to 110 kg.

In accordance with the harmonised EU Standard EN 474-5, hydraulic excavators used for lifting operations must be equipped with pipe rupture protection devices on the hoist cylinders and an overload warning device.

Backhoe Attachment

with Adjustable Up/Down Plus Offset Boom 3.60 m

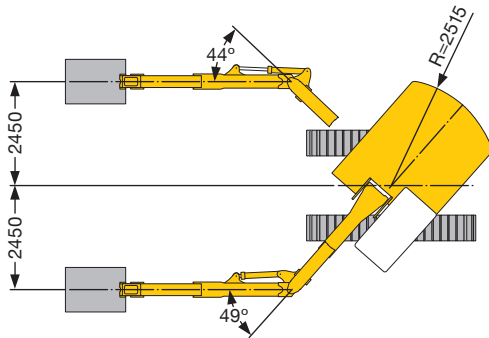
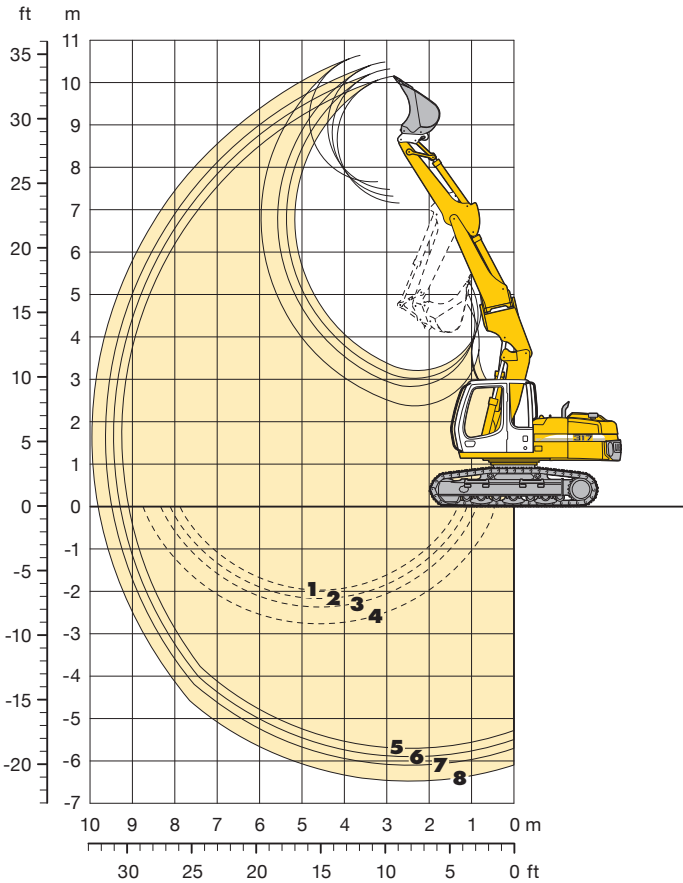

Digging Envelope with Quick Change Adapter

		5	6	7	8
Stick length	m	2.25	2.45	2.65	3.05
Max. digging depth	m	5.70	5.90	6.10	6.50
Max. reach at ground level	m	9.10	9.30	9.50	9.80
Max. dumping height	m	7.15	7.30	7.50	7.65
Max. teeth height	m	10.15	10.30	10.50	10.65
Min. attachment radius	m	2.80	2.80	2.80	2.80

- 1 stick 2.25 m
- 2 stick 2.45 m
- 3 stick 2.65 m
- 4 stick 3.05 m
- at max. attachment offset with vertical ditch walls
- 5 stick 2.25 m
- 6 stick 2.45 m
- 7 stick 2.65 m
- 8 stick 3.05 m
- with set straight boom

Digging Forces without Quick Change Adapter

		5	6	7	8
Max. digging force (ISO 6015)	kN	81.0	76.0	71.6	64.2
	t	8.3	7.7	7.3	6.5
Max. breakout force (ISO 6015)	kN	98.4	98.4	98.4	98.4
	t	10.0	10.0	10.0	10.0

Max. breakout force with ripper bucket 125.7 kN (12.8 t)
 Max. possible digging force (stick 1.70 m) 99.4 kN (10.1 t)

Operating Weight and Ground Pressure

The operating weight includes basic machine with triple grouser pads, hydr. adjustable offset boom 3.60 m, stick 2.25 m, quick change adapter 33 and bucket 1,050 mm/0.80 m³.

Undercarriage versions		Std			Std with blade		
Pad width	mm	500	600	700	500	600	700
Weight	kg	18,300	18,600	18,800	19,900	20,100	20,400
Ground pressure	kg/cm²	0.53	0.45	0.39	0.58	0.49	0.42

Undercarriage versions		SL			LC		
Pad width	mm	600	900	1000	500	600	700
Weight	kg	20,000	21,400	21,700	19,300	19,600	19,700
Ground pressure	kg/cm²	0.37	0.26	0.24	0.48	0.41	0.35

Buckets Machine stability per ISO 10567* (75% of tipping capacity)

Cutting width mm	Capacity ISO 7451 ¹⁾ m³	Weight kg	Std				Std with stabilizer blade down				SL				LC			
			Stick length (m)				Stick length (m)				Stick length (m)				Stick length (m)			
			2.25	2.45	2.65	3.05	2.25	2.45	2.65	3.05	2.25	2.45	2.65	3.05	2.25	2.45	2.65	3.05
650 ²⁾	0.45	350	□	□	□	□	□	□	□	□	□	□	□	□	□	□	□	□
850 ²⁾	0.60	400	□	□	□	□	□	□	□	□	□	□	□	□	□	□	□	□
1,050 ²⁾	0.80	480	□	△	□	△	□	□	□	□	□	□	△	□	□	□	□	△
1,250 ²⁾	0.95	520	△	■	△	■	□	△	△	■	□	△	△	■	□	△	△	■
650 ³⁾	0.45	330	□	□	□	□	□	□	□	□	□	□	□	□	□	□	□	□
850 ³⁾	0.65	380	□	□	□	□	□	□	□	□	□	□	□	□	□	□	□	□
1,050 ³⁾	0.85	460	△	△	△	■	□	□	△	■	□	□	△	■	□	□	△	■
1,250 ³⁾	1.05	500	■	■	■	▲	△	△	■	▲	△	△	■	▲	△	△	■	▲

* Indicated loads are based on ISO 10567 and do not exceed 75% of tipping or 87% of hydraulic capacity, max. stick length without quick change adapter, lifted 360° on firm

¹⁾ comparable with SAE (heaped)

²⁾ Bucket with teeth (also available in HD-version) ³⁾ Bucket with cutting lip (also available in HD-version)

Max. material weight □ = ≤ 1.8 t/m³, △ = ≤ 1.5 t/m³, ■ = ≤ 1.2 t/m³, ▲ = not authorized

Lift Capacities

with Adjustable Up/Down Plus Offset Boom 3.60 m

Stick 2.25 m

m	Undercarriage	3.0 m		4.5 m		6.0 m		7.5 m		m
		Std	LC	Std	LC	Std	LC	Std	LC	
9.0	Std, Stabilizer blade down SL LC									
7.5	Std, Stabilizer blade down SL LC			4.0* 4.0*				2.4* 2.4*	2.4* 2.4*	5.26
6.0	Std, Stabilizer blade down SL LC			4.8* 4.8*	3.3 3.8*			2.1* 2.1*	2.1* 2.1*	6.63
4.5	Std, Stabilizer blade down SL LC	6.5* 6.5*	5.1 5.6*	5.4 5.6*	3.4 4.6*			2.0* 2.0*	2.0* 2.0*	7.43
3.0	Std, Stabilizer blade down SL LC	8.8 10.3*	4.9 6.5*	3.3 4.8	2.1 3.4	1.9 2.1*	1.9 2.1*			7.86
1.5	Std, Stabilizer blade down SL LC	8.6* 10.3*	4.8 7.1*	3.2 4.8	2.0 3.3	1.7 2.2*	1.7 2.2*			7.97
0	Std, Stabilizer blade down SL LC	8.7* 11.3*	4.8 7.1*	3.0 4.8	1.9 3.2	1.7 2.5*	1.7 2.5*			7.79
-1.5	Std, Stabilizer blade down SL LC	8.3 12.2*	4.5 7.4*	2.7 4.6	1.9 3.0*	2.3 3.0*	2.3 3.0*			7.28
-3.0	Std, Stabilizer blade down SL LC	8.1 12.7*	4.1 7.2	2.6 4.0*	2.3 3.1*	2.8 3.1*	2.8 3.1*			6.36
-4.5	Std, Stabilizer blade down SL LC	7.5* 7.5*				8.9* 8.9*	8.9* 8.9*			2.62

Stick 2.45 m

m	Undercarriage	3.0 m		4.5 m		6.0 m		7.5 m		m
		Std	LC	Std	LC	Std	LC	Std	LC	
9.0	Std, Stabilizer blade down SL LC									
7.5	Std, Stabilizer blade down SL LC			3.9* 3.9*				2.2* 2.2*	2.2* 2.2*	5.56
6.0	Std, Stabilizer blade down SL LC			4.4* 4.4*	3.3 3.8*			1.9* 1.9*	1.9* 1.9*	6.86
4.5	Std, Stabilizer blade down SL LC	5.1 5.4*	5.4* 5.4*	3.4 4.5*	2.1 2.5*	1.8* 1.8*	1.8* 1.8*			7.64
3.0	Std, Stabilizer blade down SL LC	8.8 10.2*	4.9* 6.4*	3.3 4.8	2.1 3.4	1.8* 1.9*	1.8* 1.9*			8.06
1.5	Std, Stabilizer blade down SL LC	8.5 10.1*	4.8 7.1	3.2 4.8	2.0 3.3	1.7 2.0*	1.7 2.0*			8.17
0	Std, Stabilizer blade down SL LC	8.6* 11.3*	4.8 7.1	3.0 4.8*	1.9 3.2	1.7 2.2*	1.7 2.2*			7.99
-1.5	Std, Stabilizer blade down SL LC	8.3 12.1*	4.5 7.3*	2.8 4.6	1.9 3.0*	2.2 2.6*	2.2 2.6*			7.49
-3.0	Std, Stabilizer blade down SL LC	8.0 12.6*	4.1 7.2	2.6 4.4	2.2 3.1*	2.6 3.1*	2.6 3.1*			6.61
-4.5	Std, Stabilizer blade down SL LC	7.6 8.6*				4.7 5.1*	4.7 5.1*			4.05

Stick 2.65 m

m	Undercarriage	3.0 m		4.5 m		6.0 m		7.5 m		m
		Std	LC	Std	LC	Std	LC	Std	LC	
9.0	Std, Stabilizer blade down SL LC							2.7* 2.7*	2.7* 2.7*	3.57
7.5	Std, Stabilizer blade down SL LC			3.8* 3.8*				2.0* 2.0*	2.0* 2.0*	5.85
6.0	Std, Stabilizer blade down SL LC			4.1* 4.1*	3.4 3.7*			1.8* 1.8*	1.8* 1.8*	7.10
4.5	Std, Stabilizer blade down SL LC	4.9* 4.9*	3.4 4.4*	2.2 2.9*	1.7* 1.7*			1.7* 1.7*	1.7* 1.7*	7.85
3.0	Std, Stabilizer blade down SL LC	8.9 9.7*	4.9 6.2*	3.3 4.8*	2.2 3.4	1.7* 1.7*	1.7* 1.7*			8.26
1.5	Std, Stabilizer blade down SL LC	8.6* 10.2*	4.8 7.1*	3.3 4.8	2.1 3.4	1.6 1.8*	1.6 1.8*			8.37
0	Std, Stabilizer blade down SL LC	8.5 11.1*	4.9 7.1*	3.1 4.8	2.0 3.2	1.6 2.0*	1.6 2.0*			8.19
-1.5	Std, Stabilizer blade down SL LC	8.3 12.0*	4.6 7.3*	2.8 4.6	1.8 3.1	1.7 2.4*	1.7 2.4*			7.71
-3.0	Std, Stabilizer blade down SL LC	8.0 12.5*	4.2 7.3	2.6 4.4	2.1 3.0*	2.5 3.1*	2.5 3.1*			6.85
-4.5	Std, Stabilizer blade down SL LC	7.7 9.7*	4.0 4.7*			3.7 4.2*	3.7 4.2*			4.72

Stick 3.05 m

m	Undercarriage	3.0 m		4.5 m		6.0 m		7.5 m		m
		Std	LC	Std	LC	Std	LC	Std	LC	
9.0	Std, Stabilizer blade down SL LC							2.1* 2.1*	2.1* 2.1*	4.22
7.5	Std, Stabilizer blade down SL LC					2.2* 2.2*	2.1* 2.1*	1.6* 1.6*	1.6* 1.6*	6.25
6.0	Std, Stabilizer blade down SL LC					3.3* 3.3*	3.3* 3.3*	1.5* 1.5*	1.5* 1.5*	7.43
4.5	Std, Stabilizer blade down SL LC	4.2* 4.2*	3.4 4.0*	2.2 2.9*	1.4* 1.4*			1.5* 1.5*	1.5* 1.5*	8.15
3.0	Std, Stabilizer blade down SL LC	8.8* 8.8*	5.0 5.9*	3.3 4.6*	2.2 3.5	1.5* 1.5*	1.5* 1.5*			8.54
1.5	Std, Stabilizer blade down SL LC	8.5 10.4*	4.8 6.9*	3.3 4.7*	2.1 3.4	1.5 1.6*	1.5 1.6*			8.65
0	Std, Stabilizer blade down SL LC	8.4 10.9*	4.7 7.0*	3.2 4.7*	2.0 3.3	1.5 1.7*	1.5 1.7*			8.48
-1.5	Std, Stabilizer blade down SL LC	8.4 11.8*	4.6 7.1*	2.9 4.7	1.8 3.1	1.6 2.1*	1.6 2.1*			8.01
-3.0	Std, Stabilizer blade down SL LC	8.0 12.2*	4.3 7.3	2.6 4.4	1.9 2.7*	2.2 2.7*	2.2 2.7*			7.20
-4.5	Std, Stabilizer blade down SL LC	7.6 11.1*	3.9 5.9*			2.8 3.3*	2.8 3.3*			5.59

Height Can be slewed through 360° In longitudinal position of undercarriage Max. reach * Limited by hydr. capacity

The lift capacities on the load hook of the Liebherr quick-change adapter 33 without grab attachment are stated in metric tons (t) and are valid on a firm, level supporting surface. These capacities can be slewed through 360° with the undercarriage in the transverse position. Capacities in the longitudinal position of the undercarriage (+/- 15°) are specified over the stabilisers with the stabilisers down. The values apply to track pads measuring 600 mm in width when the adjusting cylinder is in the optimal position. Indicated loads comply with the ISO 10567 standard and do not exceed 75% of tipping or 87% of hydraulic capacity, or are limited by the permissible load of the load hook on the quick-change adapter (max. 5 t). Without the quick-change adapter, lift capacities will increase by up to 110 kg.

In accordance with the harmonised EU Standard EN 474-5, hydraulic excavators used for lifting operations must be equipped with pipe rupture protection devices on the hoist cylinders and an overload warning device.

Backhoe Attachment

with Adjustable Offset Boom 4.90 m

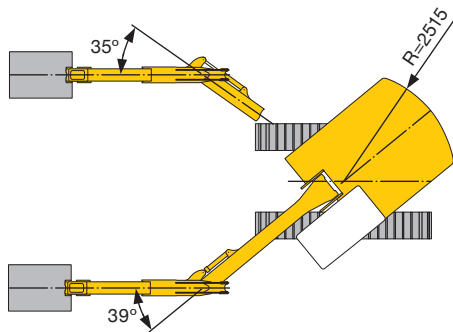
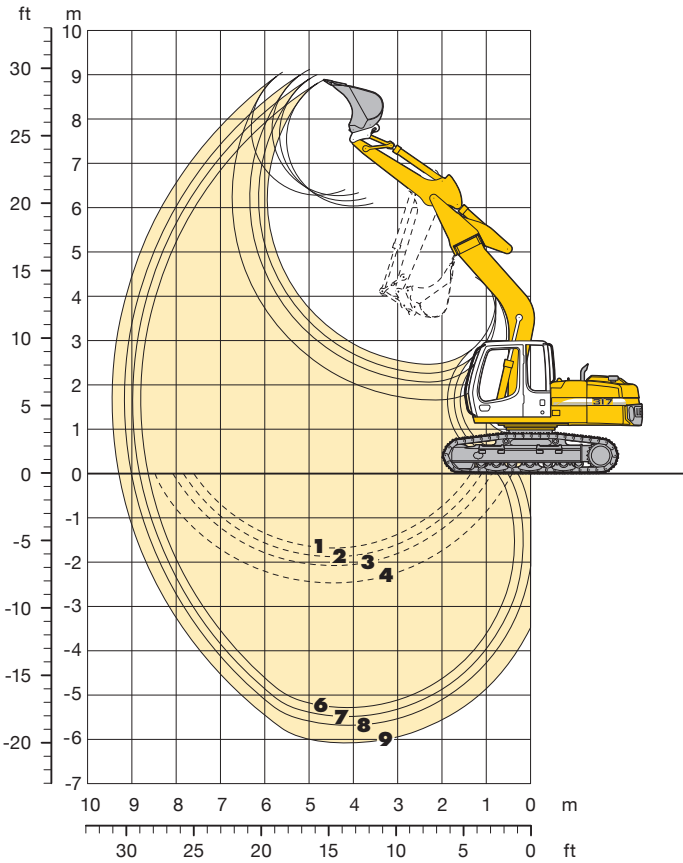

Digging Envelope with Quick Change Adapter

		5	6	7	8
Stick length	m	2.25	2.45	2.65	3.05
Max. digging depth	m	5.30	5.50	5.70	6.10
Max. reach at ground level	m	8.65	8.85	9.00	9.30
Max. dumping height	m	6.10	6.20	6.35	6.40
Min. attachment radius	m	8.90	9.00	9.15	9.05
Min. vorderer Schwenkradius	m	3.40	3.10	2.90	2.50

- 1 stick 2.25 m
 - 2 stick 2.45 m
 - 3 stick 2.65 m
 - 4 stick 3.05 m
 - 5 stick 2.25 m
 - 6 stick 2.45 m
 - 7 stick 2.65 m
 - 8 stick 3.05 m
- at max. attachment offset with vertical ditch walls
- with set straight boom

Digging Forces without Quick Change Adapter

		5	6	7	8
Max. digging force (ISO 6015)	kN	81.0	76.0	71.6	64.2
	t	8.3	7.7	7.3	6.5
Max. breakout force (ISO 6015)	kN	98.4	98.4	98.4	98.4
	t	10.0	10.0	10.0	10.0

Max. breakout force with ripper bucket 125.7 kN (12.8 t)
 Max. possible digging force (stick 1.70 m) 99.4 kN (10.1 t)

Operating Weight and Ground Pressure

The operating weight includes basic machine with triple grouser pads, adjustable offset boom 4.90 m, stick 2.25 m, quick change adapter 33 and bucket 1,050 mm/0.80 m³.

Undercarriage versions		Std			Std with blade		
Pad width	mm	500	600	700	500	600	700
Weight	kg	17,700	17,900	18,100	19,200	19,500	19,700
Ground pressure	kg/cm ²	0.51	0.43	0.38	0.56	0.47	0.41

Undercarriage versions		SL			LC		
Pad width	mm	600	900	1000	500	600	700
Weight	kg	19,400	20,700	21,000	18,600	18,900	19,100
Ground pressure	kg/cm ²	0.36	0.26	0.23	0.46	0.39	0.34

Buckets Machine stability per ISO 10567* (75% of tipping capacity)

Cutting width mm	Capacity ISO 7451 ¹⁾ m ³	Weight kg	Std				Std with stabilizer blade down				SL				LC			
			Stick length (m)				Stick length (m)				Stick length (m)				Stick length (m)			
			2.25	2.45	2.65	3.05	2.25	2.45	2.65	3.05	2.25	2.45	2.65	3.05	2.25	2.45	2.65	3.05
650 ²⁾	0.45	350	□	□	□	□	□	□	□	□	□	□	□	□	□	□	□	□
850 ²⁾	0.60	400	□	□	□	□	□	□	□	□	□	□	□	□	□	□	□	□
1,050 ²⁾	0.80	480	□	□	□	△	□	□	□	□	□	□	△	□	□	□	□	△
1,250 ²⁾	0.95	520	□	△	△	■	□	△	△	■	□	△	△	■	□	△	△	■
650 ³⁾	0.45	330	□	□	□	□	□	□	□	□	□	□	□	□	□	□	□	□
850 ³⁾	0.65	380	□	□	□	□	□	□	□	□	□	□	□	□	□	□	□	□
1,050 ³⁾	0.85	460	□	□	△	■	□	□	△	■	□	□	△	■	□	□	△	■
1,250 ³⁾	1.05	500	△	△	■	▲	△	△	■	▲	△	△	■	▲	△	△	■	▲

* Indicated loads are based on ISO 10567 and do not exceed 75% of tipping or 87% of hydraulic capacity, max. stick length without quick change adapter, lifted 360° on firm

¹⁾ comparable with SAE (heaped)

²⁾ Bucket with teeth (also available in HD-version) ³⁾ Bucket with cutting lip (also available in HD-version)

Max. material weight □ = ≤ 1.8 t/m³, △ = ≤ 1.5 t/m³, ■ = ≤ 1.2 t/m³, ▲ = not authorized

Lift Capacities

with Adjustable Offset Boom 4.90 m

Stick 2.25 m

m	Undercarriage	3.0 m		4.5 m		6.0 m		7.5 m		m
		Std	LC	Std	LC	Std	LC	Std	LC	
9.0	Std, Stabilizer blade down SL LC									
7.5	Std, Stabilizer blade down SL LC									2.0* 2.0*
6.0	Std, Stabilizer blade down SL LC									2.0* 2.0* 2.0* 2.0* 2.0* 2.0*
4.5	Std, Stabilizer blade down SL LC			4.6* 4.6*	3.1 4.1*					2.0* 2.0* 2.0* 2.0* 2.0* 2.0*
3.0	Std, Stabilizer blade down SL LC	8.5 8.8*	8.8* 8.8*	4.6 5.7*	3.0 4.6*					2.0* 2.0* 2.0* 2.0* 2.0* 2.0*
1.5	Std, Stabilizer blade down SL LC	5.9* 5.9*	5.9* 5.9*	4.2 6.9*	2.8 4.6					2.0 2.2* 2.2 2.2* 2.2 2.2*
0	Std, Stabilizer blade down SL LC	6.8* 6.8*	6.8* 6.8*	3.9 6.8	2.6 4.4					2.0 2.6* 2.4 2.6* 2.2 2.6*
-1.5	Std, Stabilizer blade down SL LC	7.0 9.8*	8.4 9.7*	3.8 6.7*	2.6 4.4					2.2 3.4* 2.6 3.4* 2.4 3.4*
-3.0	Std, Stabilizer blade down SL LC	8.5 9.1*	8.5 9.1*	4.6 6.3*	3.0 5.3*					2.8 4.7* 3.3 4.7* 3.1 4.7*
-4.5	Std, Stabilizer blade down SL LC	9.1* 9.1*	9.1* 9.1*	4.2 6.3*	3.2 5.3*					3.5 4.7*

Stick 2.45 m

m	Undercarriage	3.0 m		4.5 m		6.0 m		7.5 m		m
		Std	LC	Std	LC	Std	LC	Std	LC	
9.0	Std, Stabilizer blade down SL LC									
7.5	Std, Stabilizer blade down SL LC									2.1* 2.1* 2.1* 2.1* 2.1* 2.1*
6.0	Std, Stabilizer blade down SL LC					2.5* 2.5*				1.8* 1.8* 1.8* 1.8* 1.8* 1.8*
4.5	Std, Stabilizer blade down SL LC			4.4* 4.4*	3.1 4.1*					1.8* 1.8* 1.8* 1.8* 1.8* 1.8*
3.0	Std, Stabilizer blade down SL LC	8.2* 8.2*	8.2* 8.2*	4.6 5.5*	3.0 4.4*					1.8* 1.8* 1.8* 1.8* 1.8* 1.8*
1.5	Std, Stabilizer blade down SL LC	6.9* 6.9*	6.9* 6.9*	4.2 6.7*	2.8 4.6					1.9 2.0* 2.0 2.0* 2.0 2.0*
0	Std, Stabilizer blade down SL LC	6.9* 6.9*	6.9* 6.9*	3.9 6.8	2.6 4.4					1.9 2.3* 2.3 2.3* 2.1 2.3*
-1.5	Std, Stabilizer blade down SL LC	7.0 9.4*	8.3 9.4*	3.8 6.7	2.5 4.3					2.1 3.0* 2.5 3.0* 2.3 3.0*
-3.0	Std, Stabilizer blade down SL LC	8.4 9.5*	8.4 9.5*	4.5 6.5*	3.0 5.3*					2.6 4.4 3.1 4.6* 2.9 4.6*
-4.5	Std, Stabilizer blade down SL LC	9.0 9.4*	9.0 9.4*	4.2 6.5*	3.2 5.3*					3.2 4.6*

Stick 2.65 m

m	Undercarriage	3.0 m		4.5 m		6.0 m		7.5 m		m
		Std	LC	Std	LC	Std	LC	Std	LC	
9.0	Std, Stabilizer blade down SL LC									
7.5	Std, Stabilizer blade down SL LC									1.9* 1.9* 1.9* 1.9* 1.9* 1.9*
6.0	Std, Stabilizer blade down SL LC					2.8* 2.8*				1.7* 1.7* 1.7* 1.7* 1.7* 1.7*
4.5	Std, Stabilizer blade down SL LC			3.2 3.9*	3.7 3.8*					1.6* 1.6* 1.6* 1.6* 1.6* 1.6*
3.0	Std, Stabilizer blade down SL LC	7.7* 7.7*	7.6* 7.6*	5.3* 5.3*	3.0 4.3*					1.7* 1.7* 1.7* 1.7* 1.7* 1.7*
1.5	Std, Stabilizer blade down SL LC	8.1* 8.0*	8.1* 8.0*	4.9 6.5*	3.3 4.9*					1.8* 1.8* 1.8* 1.8* 1.8* 1.8*
0	Std, Stabilizer blade down SL LC	7.0* 7.0*	7.0* 7.0*	4.8 7.4*	3.2 5.3*					2.1 2.1* 2.1 2.1* 2.1 2.1*
-1.5	Std, Stabilizer blade down SL LC	8.0 9.1*	8.0 9.1*	4.5 7.4*	3.1 5.3*					2.0 2.7* 2.4 2.7* 2.2 2.7*
-3.0	Std, Stabilizer blade down SL LC	7.1 9.8*	8.4 9.8*	4.5 6.7*	3.0 4.7*					2.5 4.0* 2.9 4.0* 2.7 4.0*
-4.5	Std, Stabilizer blade down SL LC	9.0 9.8*	9.0 9.8*	4.7 6.7*	3.2 4.7*					4.0 4.5* 4.4 4.5* 4.4 4.5*

Stick 3.05 m

m	Undercarriage	3.0 m		4.5 m		6.0 m		7.5 m		m
		Std	LC	Std	LC	Std	LC	Std	LC	
9.0	Std, Stabilizer blade down SL LC									
7.5	Std, Stabilizer blade down SL LC									1.6* 1.6* 1.6* 1.6* 1.6* 1.6*
6.0	Std, Stabilizer blade down SL LC					2.7* 2.7*				1.4* 1.4* 1.4* 1.4* 1.4* 1.4*
4.5	Std, Stabilizer blade down SL LC			3.2 3.6*	3.6* 3.6*					1.4* 1.4* 1.4* 1.4* 1.4* 1.4*
3.0	Std, Stabilizer blade down SL LC	7.7* 7.7*	7.6* 7.6*	5.3* 5.3*	3.0 4.3*					1.4* 1.4* 1.4* 1.4* 1.4* 1.4*
1.5	Std, Stabilizer blade down SL LC	8.1* 8.0*	8.1* 8.0*	4.9 6.5*	3.3 4.9*					1.6* 1.6* 1.6* 1.6* 1.6* 1.6*
0	Std, Stabilizer blade down SL LC	7.0* 7.0*	7.0* 7.0*	4.8 7.4*	3.2 5.3*					1.6* 1.6* 1.6* 1.6* 1.6* 1.6*
-1.5	Std, Stabilizer blade down SL LC	8.0 9.1*	8.0 9.1*	4.5 7.4*	3.1 5.3*					1.9 2.3* 2.2 2.3* 2.1 2.3*
-3.0	Std, Stabilizer blade down SL LC	7.1 9.8*	8.4 9.8*	4.5 6.7*	3.0 4.7*					2.1 3.5* 2.3 3.5* 2.3 3.5*
-4.5	Std, Stabilizer blade down SL LC	9.0 9.8*	9.0 9.8*	4.7 6.7*	3.2 4.7*					3.4 4.6* 3.9 4.6* 3.7 4.6*

Height Can be slewed through 360° In longitudinal position of undercarriage Max. reach * Limited by hydr. capacity

The lift capacities on the load hook of the Liebherr quick-change adapter 33 without grab attachment are stated in metric tons (t) and are valid on a firm, level supporting surface. These capacities can be slewed through 360° with the undercarriage in the transverse position. Capacities in the longitudinal position of the undercarriage (+/- 15°) are specified over the stabilisers with the stabilisers down. The values apply to track pads measuring 600 mm in width. Indicated loads comply with the ISO 10567 standard and do not exceed 75 % of tipping or 87 % of hydraulic capacity, or are limited by the permissible load of the load hook on the quick-change adapter (max. 5 t). Without the quick-change adapter, lift capacities will increase by up to 110 kg.

In accordance with the harmonised EU Standard EN 474-5, hydraulic excavators used for lifting operations must be equipped with pipe rupture protection devices on the hoist cylinders and an overload warning device.

Attachments

Ditchcleaning Buckets/Tilting Buckets

Ditchcleaning Buckets Machine stability per ISO 10567* (75% of tipping capacity)

Cutting width mm	Capacity ISO 7451 ¹⁾ m ³	Weight kg	Std				Std with stabilizer blade down				SL				LC			
			Stick length (m)				Stick length (m)				Stick length (m)				Stick length (m)			
			2.25	2.45	2.65	3.05	2.25	2.45	2.65	3.05	2.25	2.45	2.65	3.05	2.25	2.45	2.65	3.05
Hydr. Adjustable Boom 3.40 m																		
1,500 ³⁾	0.50	360	□	□	□	□	□	□	□	□	□	□	□	□	□	□	□	□
1,600 ²⁾	0.55	640	□	□	□	□	□	□	□	□	□	□	□	□	□	□	□	□
1,600 ²⁾	0.80	770	□	□	△	■	□	□	△	■	□	□	△	■	□	□	△	■
2,000 ²⁾	0.50	660	□	□	□	□	□	□	□	□	□	□	□	□	□	□	□	□
2,000 ²⁾	0.70	790	□	□	□	■	□	□	□	■	□	□	□	■	□	□	□	■
2,000 ³⁾	0.48	350	□	□	□	□	□	□	□	□	□	□	□	□	□	□	□	□
2,000 ³⁾	0.65	390	□	□	□	□	□	□	□	□	□	□	□	□	□	□	□	□
Gooseneck Boom 5.00 m																		
1,500 ³⁾	0.50	360	□	□	□	□	□	□	□	□	□	□	□	□	□	□	□	□
1,600 ²⁾	0.55	640	□	□	□	□	□	□	□	□	□	□	□	□	□	□	□	□
1,600 ²⁾	0.80	770	□	□	△	■	□	□	△	■	□	□	△	■	□	□	△	■
2,000 ²⁾	0.50	660	□	□	□	□	□	□	□	□	□	□	□	□	□	□	□	□
2,000 ²⁾	0.70	790	□	□	□	△	□	□	□	△	□	□	□	△	□	□	□	△
2,000 ³⁾	0.48	350	□	□	□	□	□	□	□	□	□	□	□	□	□	□	□	□
2,000 ³⁾	0.65	390	□	□	□	□	□	□	□	□	□	□	□	□	□	□	□	□
Adjustable Up/Down Plus Offset Boom 3.60 m																		
1,500 ³⁾	0.50	360	□	□	□	□	□	□	□	□	□	□	□	□	□	□	□	□
1,600 ²⁾	0.55	640	□	□	□	□	□	□	□	□	□	□	□	□	□	□	□	□
1,600 ²⁾	0.80	770	△	■	△	■	□	□	△	■	□	□	△	■	□	□	△	■
2,000 ²⁾	0.50	660	□	□	□	□	□	□	□	□	□	□	□	□	□	□	□	□
2,000 ²⁾	0.70	790	△	△	△	■	□	□	△	■	□	□	△	■	□	□	△	■
2,000 ³⁾	0.48	350	□	□	□	□	□	□	□	□	□	□	□	□	□	□	□	□
2,000 ³⁾	0.65	390	□	□	□	□	□	□	□	□	□	□	□	□	□	□	□	□
Adjustable Offset Boom 4.90 m																		
1,500 ³⁾	0.50	360	□	□	□	□	□	□	□	□	□	□	□	□	□	□	□	□
1,600 ²⁾	0.55	640	□	□	□	□	□	□	□	□	□	□	□	□	□	□	□	□
1,600 ²⁾	0.80	770	□	△	△	■	□	□	△	△	■	□	□	△	△	■	□	□
2,000 ²⁾	0.50	660	□	□	□	□	□	□	□	□	□	□	□	□	□	□	□	□
2,000 ²⁾	0.70	790	□	□	△	■	□	□	△	■	□	□	□	△	■	□	□	△
2,000 ³⁾	0.48	350	□	□	□	□	□	□	□	□	□	□	□	□	□	□	□	□
2,000 ³⁾	0.65	390	□	□	□	□	□	□	□	□	□	□	□	□	□	□	□	□

Tilting Buckets Machine stability per ISO 10567* (75% of tipping capacity)

Cutting width mm	Capacity ISO 7451 ¹⁾ m ³	Weight kg	Std				Std with stabilizer blade down				SL				LC			
			Stick length (m)				Stick length (m)				Stick length (m)				Stick length (m)			
			2.25	2.45	2.65	3.05	2.25	2.45	2.65	3.05	2.25	2.45	2.65	3.05	2.25	2.45	2.65	3.05
Ausleger hydr. verstellbar 3.40 m																		
1,500 ²⁾	0.60	660	□	□	□	□	□	□	□	□	□	□	□	□	□	□	□	□
1,600 ²⁾	0.80	740	□	□	△	■	□	□	△	■	□	□	△	■	□	□	△	■
Gooseneck Boom 5.00 m																		
1,500 ²⁾	0.60	660	□	□	□	□	□	□	□	□	□	□	□	□	□	□	□	□
1,600 ²⁾	0.80	740	□	□	△	■	□	□	△	■	□	□	△	■	□	□	△	■
Adjustable Up/Down Plus Offset Boom 3.60 m																		
1,500 ²⁾	0.60	660	□	□	□	△	□	□	□	△	□	□	□	△	□	□	□	△
1,600 ²⁾	0.80	740	△	■	△	■	□	□	△	△	■	□	□	△	△	■	□	□
Adjustable Offset Boom 4.90 m																		
1,500 ²⁾	0.60	660	□	□	□	△	□	□	□	△	□	□	□	△	□	□	□	△
1,600 ²⁾	0.80	740	□	△	△	■	□	□	△	△	■	□	□	△	△	■	□	□

* Indicated loads are based on ISO 10567 and do not exceed 75 % of tipping or 87 % of hydraulic capacity, max. stick length without quick change adapter, lifted 360° on firm

¹⁾ comparable with SAE (heaped)

²⁾ with 2 x 50° rotator

³⁾ rigid ditchcleaning bucket

Max. material weight □ = ≤ 1.8 t/m³, △ = ≤ 1.5 t/m³, ■ = ≤ 1.2 t/m³, ▲ = not authorized

Equipment



Undercarriage

600 mm 3-grouser track pads	•
Track pads angled	+
Track pad widths, various	+
Travel speed levels (two)	•
Chain guide, single	•
Chain guide, additional	+
Piston rod protection support cylinders	•
Dozer blade (for Std-Undercarriage)	+
Pipe fracture safety on support cylinders	•
Cutting edge for dozer blade	+
Custom paintwork undercarriage	+
Tool box, additional in undercarriage	+



Uppercarriage

Refueling pump, electrical	+
Main battery switch for electrical system	•
Engine hood with gas spring	•
Uppercarriage doors, lockable	•
Beacon on engine hood	+
Custom paintwork uppercarriage	+
Power socket 12 V, 20 A	+
Central lubricating system, automatic	+



Hydraulics

Stop cock between hydraulic tank and pump(s)	•
Pressure test fittings	•
Accumulator for controlled lowering of the attachment with the engine shut down	•
Hydraulic oil from -20 °C to +40 °C	•
Hydraulic oil filter with integrated microfilter	•
Liebherr hydraulic oil, biologically degradable	+
Liebherr hydraulic oil, specially for warm and cold regions	+
Mowing bucket and mulcher operation	+
Bypass filter	+
Change-over for controls (hammer/shear operation via pedals or joystick)	+



Engine

Fuel theft protection	+
Fuel preheating	+
Coolant preheating 230 V	+
Liebherr particle filter	+
Fold-away fan for comfortable cleaning	•
Fan drive, reversible	+



Operator's Cab

Hourmeter, readable from the outside	•
Roof window	•
One-pedal control	+
Travel alarm	+
Fire extinguisher	+
Bottle holder	•
FOPS cab protection system	+
Slide-in front window	•
Foot support	+
Floor mat removable	•
Coat hook	•
Air conditioner	+
Consoles and seat adjustable separately or in combination	•
Cooler, electrical	+
LIDAT-Standard*	+
Liebherr proportional controls	+
Automatic engine shut-down (time adjustable)	+
Bullet proof glass (front and top)	+
Radio system	+
Smokers package	•
Rear view camera	+
Beacon	+
Tainted glass	•
Windshield washer	•
Rear wiper	+
Wiper lower front window	+
Sliding window in the door	•
Sun roller blind	•
Auxiliary heater with timer	+
Immobilizer electronic (key code)	+
Xenon headlights (front resp. rear)	+
Auxiliary headlights (front resp. rear)	+



Attachment

Main boom, adjustable in height and laterally	+
Main boom, adjustable in height	+
Function rotating device incl. tubing	+
Function hammer/shear operation incl. tubing	+
Grapple sticks	+
Hoist limitation, electronic	+
Piston rod protection bucket cylinder	+
Piston rod protection stick cylinder	+
Load hook on stick	+
Shackle on stick	+
Leak oil line, additional for attaching tools	+
Liebherr ditchcleaning bucket program	+
Liebherr pallet forks	+
Liebherr quick change adapter, hydraulic or mechanical	+
Liebherr tilting bucket program	+
Liebherr swivel rotator program	+
Liebherr sorting grapple program	+
Liebherr backhoe bucket program	+
Liebherr tooth system	+
Liebherr clamshell grapple program	+
LIKUFIX, coupling hydraulic tools from the cab	+
Gooseneck boom	+
Gooseneck boom, stretched	+
Gooseneck boom, laterally adjustable	+
Multi-User attachment	+
Pipe fracture safety boom cylinders	•
Pipe fracture safety stick resp. bucket cylinder	+
Hose quick coupling at end of stick	•
Tool-Control, 10 tool adjustments selectable over the display	+
Overload warning device	•
Bottom chord protection for stick	+
Central lubricating system, expanded for connecting link	+
Central lubrication for quick change adapter	+

• = Standard, + = Option
* = starting mid 2010

Options and/or special attachments, supplied by vendors other than Liebherr, are only to be installed with the knowledge and approval of Liebherr to retain warranty.

All illustrations and data may differ from standard equipment. Subject to change without notice.

The Liebherr Group of Companies

Wide product range

The Liebherr Group is one of the largest construction equipment manufacturers in the world. Liebherr's high-value products and services enjoy a high reputation in many other fields, too. The wide range includes domestic appliances, aerospace and transportation systems, machine tools and maritime cranes.

Exceptional customer benefit

Every product line provides a complete range of models in many different versions. With both their technical excellence and acknowledged quality, Liebherr products offer a maximum of customer benefits in practical application.

State-of-the-art technology

To provide consistent, top quality products, Liebherr attaches great importance to each product area, its components and core technologies. Important modules and components are developed and manufactured in-house, for instance the entire drive and control technology for construction equipment.

Worldwide and independent

Hans Liebherr founded the Liebherr family company in 1949. Since that time, the enterprise has steadily grown to a group of more than 100 companies with over 32,000 employees located on all continents. The corporate headquarters of the Group is Liebherr-International AG in Bulle, Switzerland. The Liebherr family is the sole owner of the company.

www.liebherr.com



Printed in Germany by DWS RG-BK-RP LHB/VF 10424654-3-04.10_enGB

Liebherr-Hydraulikbagger GmbH

Liebherrstraße 12, D-88457 Kirchdorf/Iller

☎ +49 7354 80-0, Fax +49 7354 80-7294

www.liebherr.com, E-Mail: info.lhb@liebherr.com