

374D L

Hydraulic Excavators



Engine

Engine Model

Cat® C15 ACERT®
(ATAAC)

Net Power – ISO 9249

355 kW (476 hp)

Net Power – SAE J1349

355 kW (476 hp)

Weights

Operating Weight – Long Undercarriage

Minimum – Reach Configuration

68 620 kg

Maximum – Mass Configuration

75 242 kg

Drive

Maximum Travel Speed

4.1 km/h

Maximum Drawbar Pull – Long Undercarriage

492.5 kN

374D L Features

Performance

High level of sustained production, improved quarry, heavy construction, demolition and trenching/pipelaying performance, improved reliability and durability increase your productivity and lower your operating costs.

Engine

The Cat® C15 engine uses ACERT® Technology to meet EU Stage IIIA emission regulations, with exceptional performance capabilities and proven reliability.

Operator Station

Superior cab comfort and visibility provide and excellent working environment. The monitor is a full-color, graphical display with enhanced functionality to provide a simple, comprehensive machine interface.

Maximum Versatility

A variety of work tools, including buckets, are available for applications such as demolition, site clean-up, scrap processing, breaking up road surfaces and bedrock through Cat® Work Tools.

Service and Maintenance

Fast, easy service has been designed in with long service intervals, advanced filtration, convenient filter access and user-friendly electronic diagnostics for increased productivity and reduced maintenance costs.

Contents

Hydraulics	3
Operator Station.....	4
Engine	5
Control System	6
Structures.....	7
Undercarriage	8
Front Linkage	9
SmartBoom	10
Buckets and Teeth	11
Work Tools.....	12
Environment.....	13
Service and Maintenance	14
Complete Customer Support.....	15
374D L Hydraulic Excavator Specifications..	16
374D L Standard Equipment	24
374D L Optional Equipment.....	25
Notes.....	26



The 374D L Series Excavator has durability, impressive stability and digging force, comfortable operation station, simplified service and improved hydraulic efficiency to increase your productivity and lower operating costs.

Hydraulics

Cat hydraulics deliver power and precise control to keep material moving

Main Pumps

- The hydraulic system includes two large, heavy-duty main pumps and a separate swing pump to provide quick cycle time and easier controllability during multi-function operation.
- In case the main pumps reach relief pressure, the High Pressure Cut-off System automatically destrokes the pumps to reduce energy waste and, therefore, improve fuel consumption.
- Controller reduces pump output to save energy when joysticks are in neutral position.

Proportional Priority Pressure Compensation (PPPC) Hydraulics

Main Valve

Load sensing, Proportional Priority Pressure Compensation (PPPC) allows the operator to control the cylinder speed directly related to operator's movement of joystick and not dependent on load for an easier control.

Caterpillar developed electronic actuation and offers three predefined modes activated through a switch (Soft, Normal and Quick) to match operator preference and application needs.

Electrical Regeneration Valve

A hydraulically-operated stick regeneration circuit saves energy and improves multi-function performance during stick-in operation. The boom regeneration circuit is operated electronically, managed by the controller of the machine. The system improves cycle times and fuel efficiency, increasing your productivity and reducing operating costs.

Reverse Swing Dampening Valve

Swing dampening valves reduce swing wag and produce smooth swing stops.

Advanced Features

The following are hydraulic system features of the 374D L.

- The electric re-generation system is incorporated into the hydraulic system to improve productivity and lower fuel consumption.
- The main pump flow has increased 10 percent to provide shorter cycle times.
- The main implement pressure has been increased 9 percent. This also provides shorter cycle times with higher digging forces, increased bucket fill factors.
- Stick cylinder diameter for mass and reach configurations has been increased along with the bucket cylinder diameter on the reach stick. These increases produce 17 percent higher digging forces.



Operator Station

374D L is designed for simple, easy operation and comfort



Cab Design

The spacious cab provides visibility and ergonomics. The monitor is a full-color graphical display to provide the operator with easy-to-read, comprehensive machine information. The cab provides a comfortable environment for the operator.

Hydraulic Activation Control Lever

The hydraulic activation control lever deactivates hydraulic functions during engine start-up and prevents unintentional machine operation.

Cab Exterior

Utilizes thick steel tubing along the bottom perimeter of the cab, improving the resistance to fatigue and vibration. The cab structure allows the FOGS to be bolted directly to the cab, at the factory or as an attachment.

Cab Mounts

The cab shell is attached to the frame with viscous rubber cab mounts, which dampen vibrations and sound levels while enhancing operator comfort.

Additional Features

The 374D L operator station has many features for operator comfort.

- Premium air suspension, heated seats with adjustable height consoles.
- A rear view camera is standard in Europe. The monitor functions as the display screen for the camera, providing added safety for the operator and surrounding work area.
- HID (High Intensity Discharge) lights are available as an attachment with time delay for the boom and cab lights.
- A two-way radio ready option is available.
- Automatic climate control for the air conditioner, heater and defroster.
- Fuel consumption can be displayed numerically on the monitor.



Engine

ACERT® Technology optimizes engine performance

Cat® C15 Engine

The Cat C15 engine with mechanically actuated electronic fuel injection (MEUI) powers the 374D L. The C15 has ACERT® Technology which provides advanced electronic control, precision fuel delivery and refined air management compliance.

Increased Power

The maximum power is 355 kW (476 hp), 18 percent more power than the 365C. The Power Management System (PMS) is also available to manage productivity and fuel economy.

Improved Fuel Efficiency

The 374D L fuel maps provide additional power and performance with optimized fuel consumption through flexible power settings incorporated into ADEM™ controller.

Improved Reliability

The titanium-aluminum alloy rotor in the turbocharger improves reliability/durability and contributes to faster response of the turbocharger.

Hydraulic Cooling Fan

The 374D L uses a variable speed, hydraulically-driven fan for quieter operation and reduced fuel consumption during cooler ambient conditions.

Reversible Fan

A reversible fan option is offered as an attachment. The reverse function is operated through the monitor. By selecting this function, the fan rotates in the opposite direction for a preset time to help clean the cooling package for increased uptime and reduced service cost.

Control System

Electronic management



Monitor Display Screen

The monitor is a full color, 400 × 234 pixels Liquid Crystal Display (LCD). A master caution lamp blinks ON and OFF when one of the critical conditions below occurs:

- Engine oil pressure low
- Coolant temperature high
- Hydraulic oil temperature high

Under normal conditions or the default condition, the monitor display screen is divided into four areas: clock and throttle dial, gauge, event display and multi-information display.

Gauge Display

Three analog gauges, fuel level, hydraulic oil temperature and coolant temperature are displayed in this area.

Electronic Joysticks

Electronic joysticks provide features not possible with hydraulic pilot valves:

- Eliminate pilot lines in cab for quieter operation
- Simple pattern change through the monitor

Operator Gain/Response

This is used to suit the operator preference or application.

- Quicker for fast response
- Slower, for more precision
- Contains three preset settings with 21 available

Tool Control

The unique Cat control system optimizes work tool performance and makes changeovers quick and easy. Operators can select from up to 10 pre-programmable settings from the monitor.

Alternator

The alternator is 24 volt with 75 amp capacity and is driven by a serpentine belt off the front pulley. A snorkel pulls cool, clean air from the outside for increased service life.

Product Link

Product Link is standard on the 374D L. Product Link transmits diagnostic information from the machine back to Caterpillar, Cat dealers and customers.

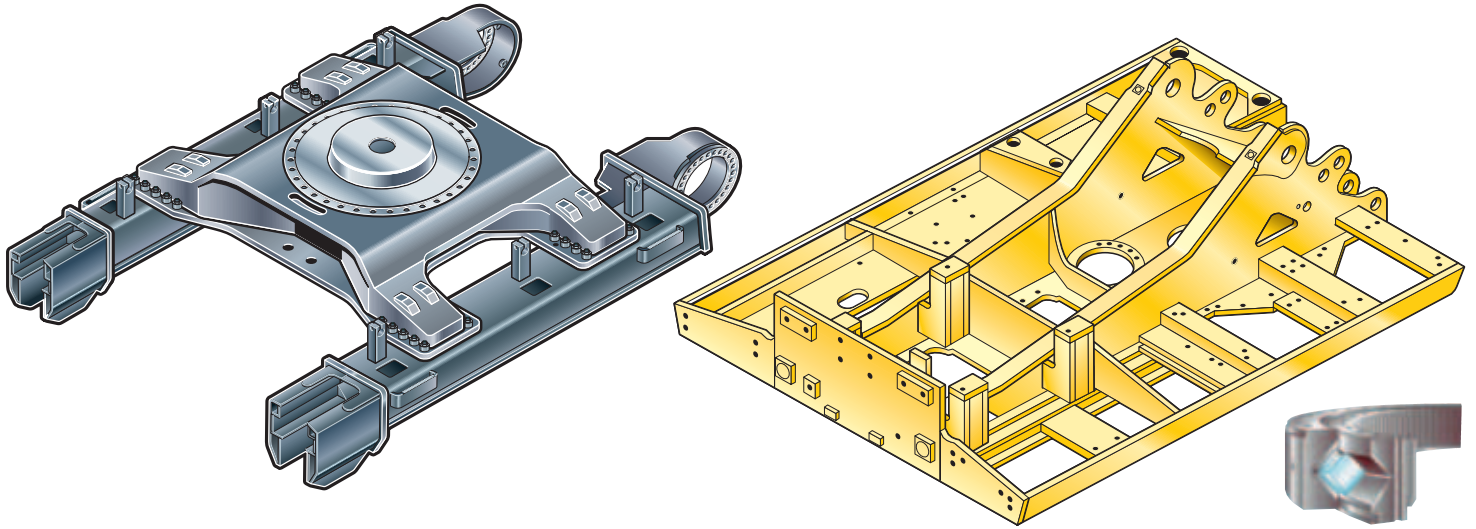

Structures

Rugged structures designed for maximum durability

Variable Gauge Undercarriage

The long variable gauge undercarriage is standard, providing a wide, stable base for operating, or a narrow gauge for reduced shipping width. The undercarriage gauge in working position has been increased by 160 mm (6.3 in) for improved stability.

Upper Frame

The upper frame is designed for maximum durability and efficient use of materials. The boomfoot, skirt and counterweight mounting area have been strengthened for longer service life and increased durability.

- Outer frame utilizes curved side rails, which are die-formed for excellent uniformity and strength through the length
- Box section channels improve upper frame rigidity under the cab
- Boom tower and one piece main rails are constructed of solid, high-tensile strength steel plates

Catwalk

The catwalk width has been extended to 500 mm (+28 percent wider than the 365C L). Catwalks are provided on both sides of the skirt for easy access of the maintenance points. Slip resistant plates are used on the full length of the catwalks.

Cross Roller Bearing

The 374D L swing bearing is a cross roller type, with 54 mm diameter rollers. The cross rollers have a much greater contact area than ball bearing, providing increased stability and longer life.

Track Roller Frames

The track roller frame is made of thick, steel plate that is bent into a U-shape and welded to the bottom plate to create a box structure. The box structure design provides increased rigidity and impact resistance.

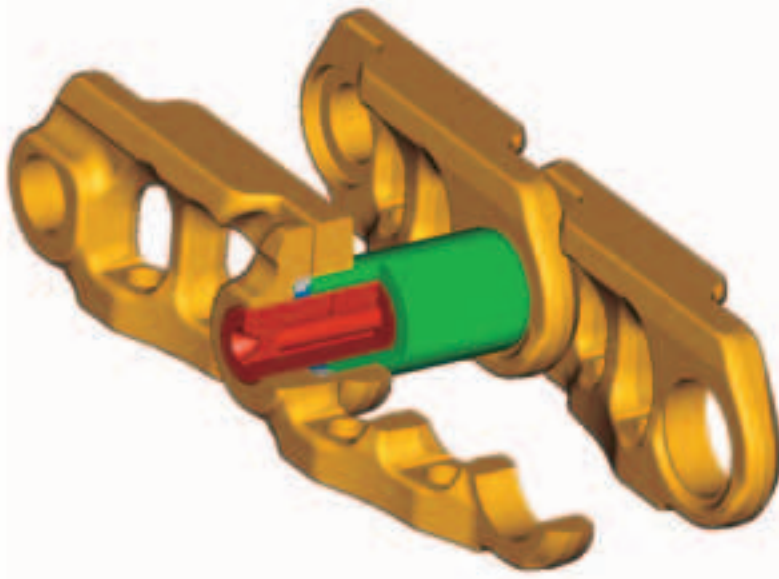

Undercarriage

The link that transmits the reaction forces from digging to the ground

Undercarriage

The undercarriage supports the swing bearing and upper structure and is the link that transmits the reaction forces from digging to the ground. The strength of the undercarriage plays a major factor in machine stability and durability.

Track Roller Frame

The track roller frame has been improved by installing a longer stroke recoil spring and lowering the front idler. The longer recoil spring improves durability and service life of the undercarriage while the offset idler increases the stability of the machine while working over the front.

Positive Pin Retention 2 (PPR2)

Track links with the PPR2 are provided as standard on the 374D L. The PPR2 track link is designed to prevent looseness of the track pin in the track link and to reduce stress concentrations. The PPR2 system eliminates pin walking for increased service life.

Carrier Rollers

The carrier rollers use a floating “Duo-Cone” seal. The Duo-Cone seal protects the moving parts in the carrier roller from water and dirt, and makes lubrication maintenance-free.

Cast Idler

The more durable cast idler is standard on the 374D L.

Front Linkage

Designed for flexibility and high productivity

Front Linkage

Cat excavator booms and sticks are built for performance and long service life.

- Castings and forgings are used at high stress areas such as boom nose, boom foot, boom cylinder and stick foot.
- All booms and sticks are stress-relieved for optimal life and durability, while minimizing weight for improved performance.
- All booms and sticks are ultrasonic inspected.

Bucket Linkage

Two bucket linkages are available for the 374D L. Both linkages are available with or without a lifting eye on the power link.

- The VB2 bucket linkage is for use with the reach sticks and VB2-family buckets
- The WB2 bucket linkage is for use with the mass sticks and WB2-family buckets

Boom Construction

374D L booms feature a large cross-section to improve strength and reduce weight. Baffle plates reinforce the boom interior for higher rigidity. Booms are designed for strength and maximum payload.

Stick Construction

Sticks are made of high-tensile strength steel in a box-section design, making them strong and light. All sticks are reinforced with a thick baffle plate for added rigidity. The connection between stick and boom is made of forged steel, and a thick steel plate is used at the bucket connecting location for increased strength and rigidity at load-bearing points. An additional wear plate is added to the working side of the stick for protection. All mass sticks include additional wear bars on the working side to protect the structure during operation. There are four reach sticks and two mass sticks available to meet your application needs.

Linkage Pins

Bucket cylinder pin and idler to stick pin diameter for the reach boom have been increased. The pins have thick chrome plating for high wear resistance long life.

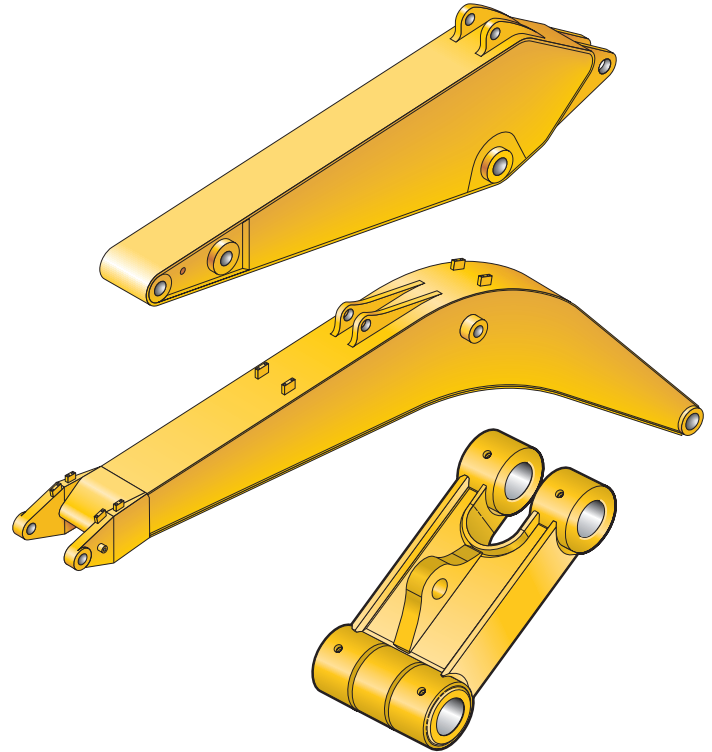

SmartBoom

Reduces stress and vibrations transmitted to the machine

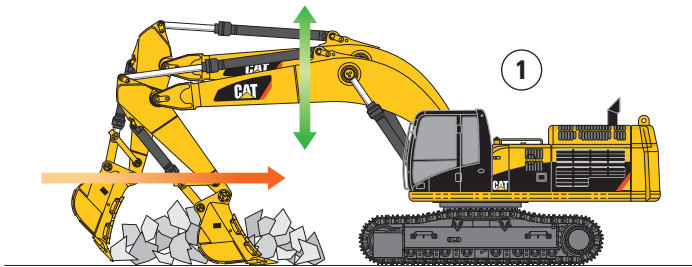

Rock Scraping (1)

Scraping rock and finishing work is easy and fast. SmartBoom simplifies the task and allows the operator to fully concentrate on stick and bucket, while boom freely goes up and down without using pump flow.

Hammer Work (2)

It has never been this productive and operator-friendly. The front parts automatically follow the hammer while penetrating the rock. Blank shots or excessive force on the hammer are avoided resulting in longer life for the hammer and the machine. Similar advantages are applicable when using vibratory plates.

Truck Loading (3)

Loading trucks from a bench is more productive and more fuel efficient as the return cycle is reduced while the boom down function does not require pump flow.

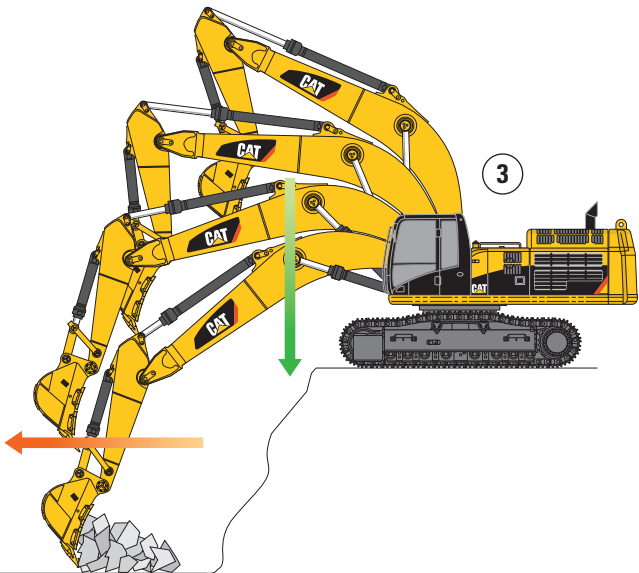
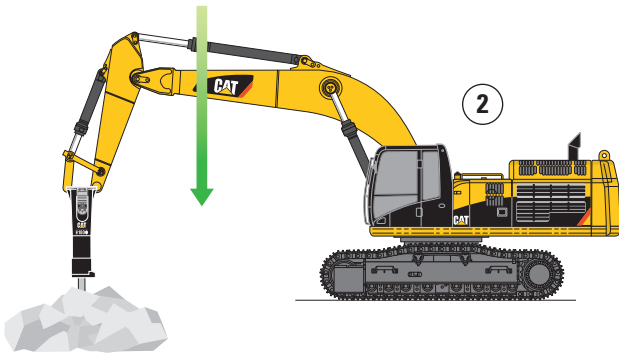

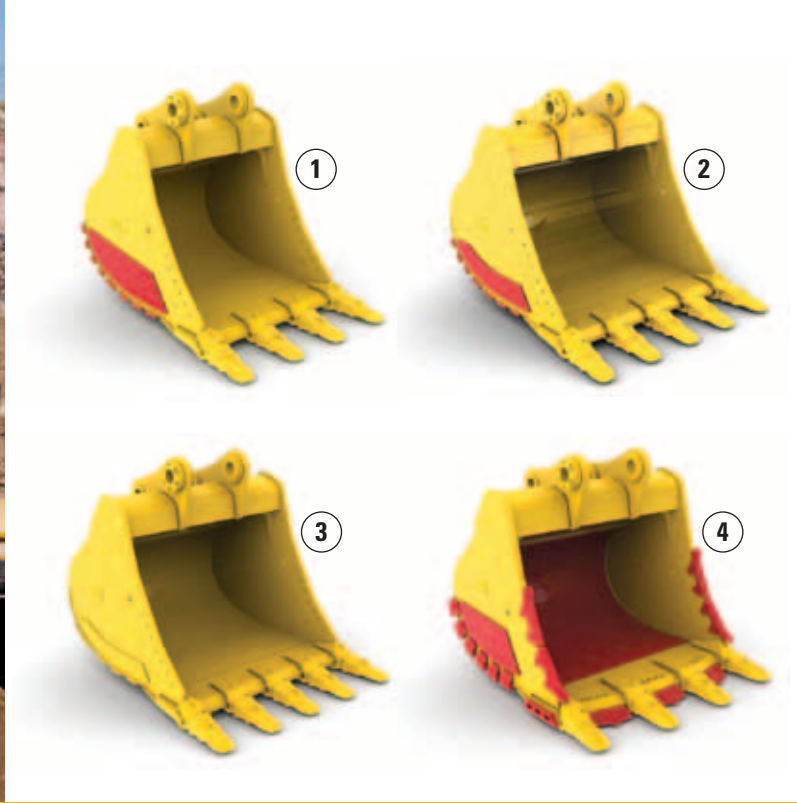

Buckets and Teeth

Designed and built for total system performance

Optimized Package

Caterpillar offers a wide range of buckets, each designed and field tested to function as an integral part of your excavator. All Cat Buckets feature K Series™ GET (Ground Engaging Tools). Buckets are available in four levels of durability and are built to take full advantage of the machine's power.

General Duty (GD)

General Duty buckets are designed for use in low impact, lower abrasion materials such as dirt, loam and mixed compositions of dirt and fine gravel.

Heavy Duty (HD)

Heavy Duty buckets are the most popular and a good “centerline” choice. This bucket style is a good starting point when application conditions are not known. Heavy Duty buckets are designed for a wide range of impact and abrasion conditions including mixed dirt, clay and rock.

Severe Duty (SD)

Severe Duty buckets are designed for higher abrasion conditions such as shot granite. When compared to the Heavy Duty bucket, wear bars and wear plates are substantially thicker and larger for added protection.

Extreme Duty (XD)

Extreme Duty buckets are designed for very high abrasion conditions such as granite quarries. Corner shrouds have been added and side wear plates are larger for added protection.

1) Severe Duty 2) Heavy Duty 3) General Duty 4) Extreme Duty

Work Tools

Solutions for your business



Increase Machine Versatility

The Cat combination of machine and tool provides a total solution for just about any application. Work tools can be mounted directly to the machine or a quick coupler can be added, making it quick and easy to release one work tool and pick up another.

Quick Couplers

Cat quick couplers enable the operator to simply release one work tool and pick up another. Your hydraulic excavator becomes highly versatile. The dedicated CW-Series quick coupler enables a quick tool exchange while maintaining top machine performance. A lifting hook is added for maximum lift capacity.

Work Tools

An extensive range of Cat Work Tools for the 374D L includes buckets, hammers, grapples, shears, multi-processors and rippers. Each are designed to optimize the versatility and performance of your machine. Cat Work Tools and couplers are ready to work in a variety of applications, such as site and structure demolition, debris clean-up, truck loading, scrap processing, breaking road surfaces and bed rock.

Hydraulic Kits

Caterpillar offers field-installed hydraulic kits designed to simplify the process of ordering and installing the right kit. Modular kit designs integrate Cat Work Tools with Cat Hydraulic Excavators. Every kit is easy to install. Hoses are pre-made, tubes are pre-bent and pre-painted and there are comprehensive instructions.



Environment

374D L meets a wide range of environmental requirements

Emissions

ACERT® Technology is a differentiated technology that reduces emissions at the point of combustion. The technology capitalizes on proven Caterpillar leadership in three core engine systems: fuel, air and electronics.

Electro Magnetic Compliance

The 374D L meets the following EMC (Electro Magnetic Compliance) requirements:

- ISO 13766 Earth Moving Machinery – Electromagnetic compliance
- EU Directive 89/336/EEC
- Aus EMC Framework

Fluid Management

Several serviceability elements are designed into the 374D L to limit fluid spillage while performing routine maintenance.

Ecology Drains

Ecology drains are provided for the fuel and hydraulic tanks, allowing fluids to be captured in a container when draining the tanks.

Service and Maintenance

Fast, easy service has been designed into the 374D L



Service Intervals

Long service intervals reduce maintenance costs. Engine oil, oil filter and fuel filters are at 500 hours.

Oil Sample and Pressure Ports

Oil sample and pressure ports provide easy checking of machine condition and are standard on every machine.

Hydraulic Capsule Filters

The return filters or capsule filters for the hydraulic system are located beside the hydraulic tank. The filter elements are removable without spilling hydraulic oil.

Service Points

Service points are centrally located with easy access to facilitate routine maintenance.

Pilot Hydraulic System Filter

Pilot hydraulic system filter keeps contaminants from the pilot system and is located in the pump compartment.

Remote Greasing Block

A concentrated remote greasing block on the boom delivers grease to hard-to-reach locations.

Radial Seal Cleaner

Radial seal main air cleaner with pre-cleaner has a double-layered filter element for more efficient filtration. No tools are required to change the element.

Fuel-Water Separator

The water separator removes water from fuel, even when under pressure, and the water level can be monitored in the cab.



Complete Customer Support

Cat dealer services help you operate longer with lower costs

Product Support

Cat dealers utilize a worldwide computer parts network to minimize machine downtime. Save money with Cat remanufactured components.

Machine Selection

Make detailed comparisons of machines you are considering. What are job requirements and machine attachments? What production is needed? Your Cat dealer can provide recommendations.

Purchase

Consider financing options and day-to-day operating costs. Look at dealer services that can be included in the machine's cost to yield lower owning and operating costs over time.

Customer Support Agreements

Cat dealers offer a variety of product support agreements and work with you to develop a plan to meet specific needs. These plans can cover the entire machine, including attachments, to help protect your investment.

Operation

Improving operating techniques can boost your profits. Your Cat dealer has videos, literature and other ideas to help you increase productivity, and Caterpillar offers certified operator training to help maximize the return on your investment.

Maintenance Services

Repair option programs guarantee repair costs up front. Diagnostic programs such as Scheduled Oil Sampling, Coolant Sampling and Technical Analysis help you avoid unscheduled repairs.

Replacement

Repair, rebuild or replace? Your Cat dealer can help you evaluate the cost involved so you can make the right choice.

374D L Hydraulic Excavator Specifications

Engine

Engine Model	Cat® C15 ACERT® (ATAAC)
Net Flywheel Power	355 kW (476 hp)
Net Power – ISO 9249	355 kW (476 hp)
Net Power – SAE J1349	355 kW (476 hp)
Net Power – EEC 80/1269	355 kW (476 hp)

Bore	137 mm
Stroke	171 mm
Displacement	15.2 L

- The 374D L meets EU Stage IIIA or Stage II emission requirements.
- No engine power derating required below 2300 m altitude.
- Net power advertised is the power available at the flywheel when the engine is equipped with fan, air cleaner, muffler and alternator.

Weights

Operating Weight – Long Undercarriage	75 242 kg
• Mass Boom, M2.57 stick, bucket 4.4 m ³ and 650 mm shoes.	

Track

Optional for Long Undercarriage	900 mm
Optional for Long Undercarriage	750 mm
Optional for Long Undercarriage	650 mm
Number of Shoes Each Side – Standard Undercarriage	47
Number of Track Rollers Each Side – Long Undercarriage	8
Number of Carrier Rollers Each Side	3

Swing Mechanism

Swing Speed	6.4 rpm
Swing Torque	214.8 kN·m

Drive

Maximum Travel Speed	4.1 km/h
Maximum Drawbar Pull	492.5 kN

Hydraulic System

Main System – Maximum Flow (Total)	880 L/min
Swing System – Maximum Flow	360 L/min
Maximum Pressure – Equipment – Normal	35 000 kPa
Maximum Pressure – Travel	35 000 kPa
Maximum Pressure – Swing	29 400 kPa
Pilot System – Maximum Flow	87 L/min
Pilot System – Maximum Pressure	4120 kPa
Boom Cylinder – Bore	190 mm
Boom Cylinder – Stroke	1792 mm
Stick Cylinder – Bore	210 mm
Stick Cylinder – Stroke	2118 mm
VB2-Family Bucket Cylinder – Bore	190 mm
VB2-Family Bucket Cylinder – Stroke	1443 mm
WB2-Family Bucket Cylinder – Bore	200 mm
WB2-Family Bucket Cylinder – Stroke	1457 mm

Service Refill Capacities

Fuel Tank Capacity	935 L
Cooling System	95 L
Engine Oil	65 L
Swing Drive (each)	12 L
Final Drive (each)	15 L
Hydraulic System (including tank)	670 L
Hydraulic Tank	310 L

Sound Performance

Performance	Meets specified standards
• Operator Sound – The operator sound level measured according to the procedures specified in ISO 6394:1998 is 85 dB(A), for cab offered by Caterpillar, when properly installed and maintained and tested with doors and windows closed.	
• Exterior Sound – The labeled spectator sound power level measured according to the test procedures and conditions specified in 2000/14/EC is 107 dB(A).	
• Hearing protection may be needed when operating with an open operator station and cab (when not properly maintained for doors/windows open) for extended periods or in a noisy environment.	

Standards

Brakes	SAE J1026 APR90
Cab/FOGS	SAE J1356 FEB88, ISO 10262
• ISO 10262 OPS, front and top	
• ISO J1356 FOGS, front and top	

Dimensions

All dimensions are approximate

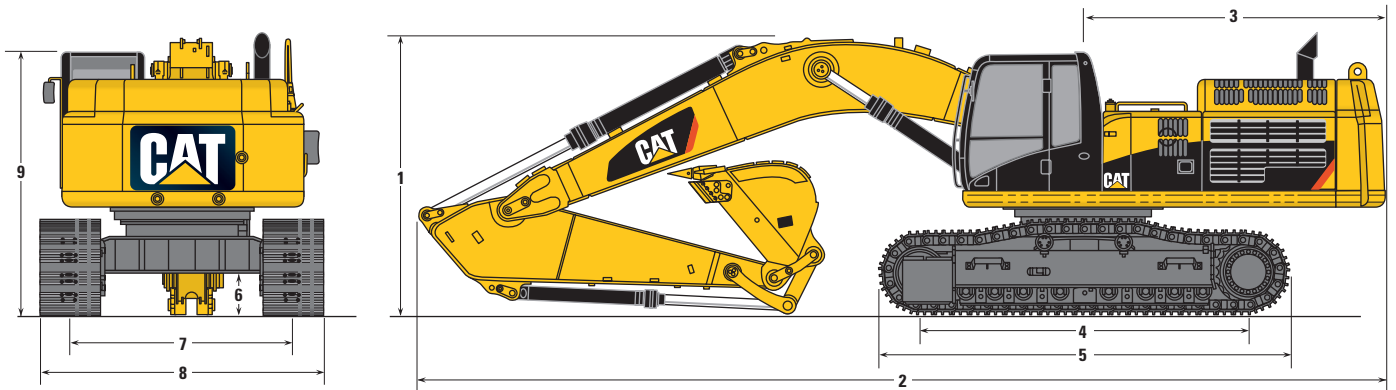

Stick	Reach Boom 7.8 m				Mass Boom 7.0 m	
	R4.67 m	R4.15 m	R3.6 m	R2.84 m	M3.0 m	M2.57 m
1 Shipping Height	4980 mm	4650 mm	4480 mm	4380 mm	4740 mm	4560 mm
2 Shipping Length	13 220 mm	13 310 mm	13 320 mm	13 470 mm	12 630 mm	12 670 mm
3 Tail Swing Radius	4020 mm	4020 mm	4020 mm	4020 mm	4020 mm	4020 mm
4 Length to Center of Rollers	4705 mm	4705 mm	4705 mm	4705 mm	4705 mm	4705 mm
5 Track Length	5860 mm	5860 mm	5860 mm	5860 mm	5860 mm	5860 mm
6 Ground Clearance	840 mm	840 mm	840 mm	840 mm	840 mm	840 mm
7 Track Gauge (Shipping)*	2750 mm	2750 mm	2750 mm	2750 mm	2750 mm	2750 mm
8 Transport Width**	3500 mm	3500 mm	3500 mm	3500 mm	3500 mm	3500 mm
9 Cab Height	3535 mm	3535 mm	3535 mm	3535 mm	3535 mm	3535 mm

* Track gauge in extended (working) position: 3410 mm.

** Transport width shown for 750 mm.

Add 150 mm for 900 mm shoes.

Subtract 100 mm for 650 mm shoes.

374D L Hydraulic Excavator Specifications

Working Ranges

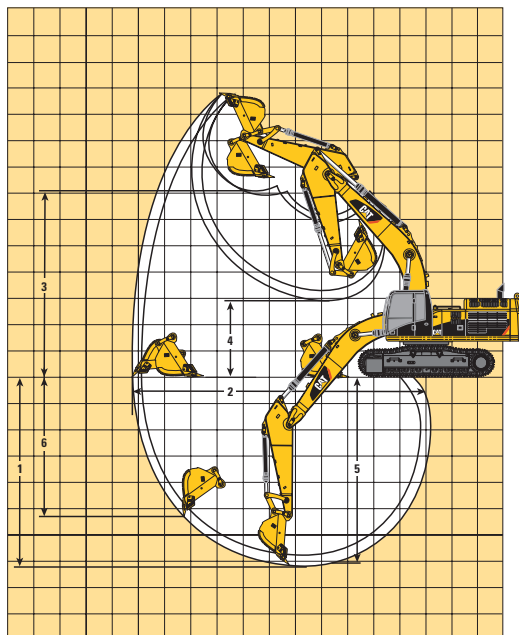

Stick Bucket	Reach Boom 7.8 m				Mass Boom 7.0 m	
	R4.67 m GD	R4.15 m GD	R3.6 m GD	R2.84 m GD	M3.0 m SD	M2.57 m SD
1 Maximum Digging Depth	9650 mm	9130 mm	8580 mm	7820 mm	7610 mm	7180 mm
2 Maximum Reach at Ground Line	14 450 mm	13 690 mm	13 170 mm	12 780 mm	11 810 mm	11 420 mm
3 Maximum Loading Height	9000 mm	8650 mm	8420 mm	8250 mm	7280 mm	7110 mm
4 Minimum Loading Height	2240 mm	2760 mm	3310 mm	4070 mm	3100 mm	3520 mm
5 Maximum Depth Cut for 2240 mm Level Bottom	9540 mm	9010 mm	8450 mm	7670 mm	7460 mm	7030 mm
6 Maximum Vertical Wall Digging Depth	8430 mm	7740 mm	7040 mm	6570 mm	4340 mm	3970 mm
Bucket Digging Force (SAE)*	297.5 kN	297.5 kN	296.9 kN	295.3 kN	347.4 kN	347.0 kN
Bucket Digging Force (ISO)*	339.4 kN	339.4 kN	338.6 kN	336.8 kN	390.2 kN	389.8 kN
Stick Digging Force (SAE)	227.1 kN	245.6 kN	269.4 kN	299.7 kN	298.2 kN	324.7 kN
Stick Digging Force (ISO)	234.0 kN	253.9 kN	279.3 kN	312.1 kN	307.0 kN	335.6 kN

*Bucket tip radius is 2251mm.

Operating Weight and Ground Pressure

	Track					
	900 mm Shoes		750 mm Shoes		650 mm Shoes	
	kg	bar	kg	bar	kg	bar
Reach Boom 7.8 m						
GP Bucket 3.8 m ³						
R4.67 m	73 221	0.78	72 172	0.92	71 494	1.0
R4.15 m	73 010	0.78	71 961	0.92	71 283	1.0
R3.60 m	72 859	0.78	71 810	0.92	71 132	1.0
R2.84 m	72 686	0.78	71 637	0.91	70 959	1.0
Mass Boom 7.0 m						
HDR Bucket 4.6 m ³						
M3.00 m	75 596	0.79	74 547	0.94	73 869	1.1
M2.57 m	75 422	0.79	74 373	0.94	73 695	1.1

Major Component Weights

	kg
Base machine with counterweight and 750 mm shoes (without front linkage)	57 700
Two boom cylinders	1400
Counterweight	
Removal type	10 200
Non-removal type	10 960
Boom (includes lines, pins, stick cylinder)	
Reach Boom 7.8 m	6730
Mass Boom 7.0 m	6900
Stick (includes lines, pins, bucket cylinder and linkage)	
R4.67 m	4000
R4.15 m	3790
R3.60 m	3670
R2.84 m	3470
M3.00 m	4070
M2.57 m	4240

374D L Hydraulic Excavator Specifications

Reach Boom Lift Capacities



Load Point Height



Load at Maximum Reach



Load Radius Over Front



Load Radius Over Side

Boom – 7.8 m

Coupler – N/A

Bucket – None

Stick – R4.67 m

Shoes – 750 mm double grouser (HD)

Load Point Height	kg	1.5 m		3.0 m		4.5 m		6.0 m		7.5 m		9.0 m		10.5 m		12.0 m		m		
		Front	Side	Front	Side	Front	Side	Front	Side	Front	Side	Front	Side	Front	Side	Front	Side	Front	Side	
10.5 m	kg											*11 750	*11 750					*10 800	*10 800	9.20
9.0 m	kg											*12 450	*12 450					*10 200	*10 200	10.33
7.5 m	kg											*12 750	*12 750	*12 250	11 700			*9900	*9900	11.14
6.0 m	kg											*13 450	*13 450	*12 500	11 500			*9850	9500	11.70
4.5 m	kg					*26 500	*26 500	*20 000	*20 000	*16 550	*16 550	*14 450	14 350	*13 050	11 200	*10 400	8950	*10 000	8900	12.04
3.0 m	kg							*23 050	*23 050	*18 300	18 050	*15 450	13 750	*13 600	10 850	*12 050	8750	*10 350	8550	12.20
1.5 m	kg							*25 350	23 750	*19 750	17 200	*16 350	13 200	*14 100	10 550	11 900	8600	*10 850	8450	12.16
Ground Line	kg					*17 300	*17 300	*26 500	22 850	*20 650	16 550	*16 950	12 800	14 300	10 250			*11 700	8550	11.93
-1.5 m	kg			*12 500	*12 500	*22 700	*22 700	*26 400	22 400	*20 800	16 200	*17 000	12 550	14 150	10 100			*12 450	8950	11.50
-3.0 m	kg	*15 350	*15 350	*19 700	*19 700	*30 800	*30 800	*25 250	22 350	*20 100	16 050	*16 350	12 450	*13 250	10 100			*12 450	9700	10.85
-4.5 m	kg			*28 450	*28 450	*29 000	*29 000	*22 850	22 500	*18 300	16 150	*14 600	12 550					*12 250	11 100	9.92
-6.0 m	kg			*29 550	*29 550	*23 450	*23 450	*18 800	*18 800	*14 800	*14 800							*11 550	*11 550	8.63

Boom – 7.8 m

Coupler – N/A

Bucket – None

Stick – R4.15 m

Shoes – 750 mm double grouser (HD)

Load Point Height	kg	1.5 m		3.0 m		4.5 m		6.0 m		7.5 m		9.0 m		10.5 m		m		
		Front	Side	Front	Side	Front	Side	Front	Side	Front	Side	Front	Side	Front	Side	Front	Side	
10.5 m	kg															*12 450	*12 450	8.47
9.0 m	kg											*13 350	*13 350			*11 750	*11 750	9.68
7.5 m	kg											*13 550	*13 550	*11 800	11 550	*11 400	*11 400	10.55
6.0 m	kg									*15 800	*15 800	*14 200	*14 200	*13 150	11 450	*11 400	10 300	11.14
4.5 m	kg							*21 300	*21 300	*17 400	*17 400	*15 100	14 250	*13 600	11 150	*11 600	9600	11.50
3.0 m	kg							*24 200	*24 200	*19 050	17 900	*16 050	13 700	*14 100	10 850	*12 100	9200	11.66
1.5 m	kg							*26 150	23 550	*20 350	17 150	*16 850	13 200	*14 450	10 550	12 550	9100	11.62
Ground Line	kg					*16 850	*16 850	*26 850	22 850	*21 000	16 600	*17 250	12 850	14 400	10 350	12 800	9250	11.38
-1.5 m	kg			*13 350	*13 350	*24 050	*24 050	*26 350	22 600	*20 850	16 300	*17 050	12 650	*14 100	10 250	*13 250	9750	10.93
-3.0 m	kg			*22 100	*22 100	*31 450	*31 450	*24 750	22 600	*19 850	16 250	*16 100	12 650			*13 200	10 700	10.24
-4.5 m	kg			*32 500	*32 500	*27 200	*27 200	*21 850	*21 850	*17 550	16 450	*13 650	12 850			*12 900	12 450	9.25
-6.0 m	kg					*20 850	*20 850	*17 000	*17 000	*13 000	*13 000					*11 850	*11 850	7.85

*Indicates that the load is limited by hydraulic lifting capacity rather than tipping load. The above loads are in compliance with hydraulic excavator lift capacity standard ISO 10567:2007. They do not exceed 87% of hydraulic lifting capacity or 75% of tipping load. Weight of all lifting accessories must be deducted from the above lifting capacities. Lifting capacities are based on the machine standing on a firm, uniform supporting surface.

Always refer to the appropriate Operation and Maintenance Manual for specific product information.

Reach Boom Lift Capacities



Load Point Height



Load at Maximum Reach



Load Radius Over Front



Load Radius Over Side

Boom – 7.8 m

Coupler – N/A

Bucket – None

Stick – R3.6 m

Shoes – 750 mm double grouser (HD)

Diagram		1.5 m		3.0 m		4.5 m		6.0 m		7.5 m		9.0 m		10.5 m		Diagram		m	
		Front	Side	Front	Side	Front	Side	Front	Side	Front	Side	Front	Side	Front	Side	Front	Side		
10.5 m	kg																*14 850	*14 850	7.75
9.0 m	kg											*14 350	*14 350				*13 900	*13 900	9.06
7.5 m	kg									*15 450	*15 450	*14 300	*14 300				*13 500	12 450	9.98
6.0 m	kg							*19 600	*19 600	*16 650	*16 650	*14 850	14 550	*13 800	11 250		*13 450	11 100	10.60
4.5 m	kg							*22 500	*22 500	*18 200	*18 200	*15 650	14 050	*14 050	11 050		*13 700	10 250	10.98
3.0 m	kg							*25 150	24 350	*19 700	17 650	*16 500	13 550	*14 450	10 800		13 500	9850	11.15
1.5 m	kg							*26 650	23 300	*20 750	17 000	*17 150	13 150	14 600	10 550		13 400	9700	11.11
Ground Line	kg							*26 850	22 800	*21 150	16 550	*17 350	12 850	14 400	10 400		13 750	9950	10.86
-1.5 m	kg					*24 650	*24 650	*25 900	22 650	*20 700	16 350	*16 900	12 700				*13 900	10 500	10.39
-3.0 m	kg			*24 250	*24 250	*29 550	*29 550	*23 850	22 750	*19 250	16 400	*15 500	12 750				*13 750	11 700	9.65
-4.5 m	kg			*29 150	*29 150	*24 750	*24 750	*20 350	*20 350	*16 350	*16 350						*13 200	*13 200	8.60
-6.0 m	kg							*14 450	*14 450								*11 400	*11 400	7.07

Boom – 7.8 m

Coupler – N/A

Bucket – None

Stick – R2.84 m

Shoes – 750 mm double grouser (HD)

Diagram		1.5 m		3.0 m		4.5 m		6.0 m		7.5 m		9.0 m		10.5 m		Diagram		m	
		Front	Side	Front	Side	Front	Side	Front	Side	Front	Side	Front	Side	Front	Side	Front	Side		
10.5 m	kg																*17 550	*17 550	6.81
9.0 m	kg									*16 300	*16 300						*16 050	*16 050	8.28
7.5 m	kg									*16 700	*16 700	*15 500	14 600				*15 400	13 850	9.27
6.0 m	kg					*28 400	*28 400	*21 300	*21 300	*17 800	*17 800	*15 800	14 350				*15 050	12 200	9.94
4.5 m	kg							*24 100	*24 100	*19 200	18 200	*16 450	13 900				*14 900	11 200	10.35
3.0 m	kg							*26 300	23 800	*20 450	17 400	*17 100	13 450	14 800	10 750		14 750	10 750	10.52
1.5 m	kg							*27 050	23 000	*21 200	16 850	*17 500	13 100				14 650	10 650	10.48
Ground Line	kg							*26 500	22 750	*21 150	16 550	*17 350	12 900				*14 800	10 900	10.22
-1.5 m	kg					*23 400	*23 400	*24 900	22 800	*20 250	16 450	*16 450	12 850				*14 650	11 700	9.71
-3.0 m	kg					*26 200	*26 200	*22 250	*22 250	*18 150	16 600						*14 150	13 250	8.92
-4.5 m	kg					*20 850	*20 850	*17 900	*17 900	*13 900	*13 900						*12 900	*12 900	7.76

*Indicates that the load is limited by hydraulic lifting capacity rather than tipping load. The above loads are in compliance with hydraulic excavator lift capacity standard ISO 10567:2007. They do not exceed 87% of hydraulic lifting capacity or 75% of tipping load. Weight of all lifting accessories must be deducted from the above lifting capacities. Lifting capacities are based on the machine standing on a firm, uniform supporting surface.

Always refer to the appropriate Operation and Maintenance Manual for specific product information.

374D L Hydraulic Excavator Specifications

Mass Boom Lift Capacities



Load Point Height



Load at Maximum Reach



Load Radius Over Front



Load Radius Over Side

Boom – 7.0 m

Coupler – N/A

Bucket – None

Stick – M3.0 m

Shoes – 750 mm double grouser (HD)

Load Point Height	kg	1.5 m		3.0 m		4.5 m		6.0 m		7.5 m		9.0 m		m		
		Front	Side	Front	Side	Front	Side	Front	Side	Front	Side	Front	Side	Front	Side	
9.0 m	kg													*13 850	*13 850	7.35
7.5 m	kg									*16 250	*16 250			*13 100	*13 100	8.45
6.0 m	kg							*19 550	*19 550	*17 050	*17 050	*15 700	14 100	*12 900	*12 900	9.18
4.5 m	kg					*30 350	*30 350	*22 250	*22 250	*18 350	*18 350	*16 150	13 750	*13 150	12 300	9.62
3.0 m	kg							*24 850	24 450	*19 700	17 550	*16 750	13 350	*13 750	11 700	9.81
1.5 m	kg							*26 450	23 350	*20 700	16 900	*17 200	13 000	*14 800	11 550	9.76
Ground Line	kg					*29 000	*29 000	*26 700	22 800	*20 950	16 500	*17 100	12 750	*15 950	11 900	9.48
-1.5 m	kg			*23 900	*23 900	*32 900	*32 900	*25 550	22 650	*20 200	16 350			*16 050	12 900	8.93
-3.0 m	kg			*35 400	*35 400	*28 850	*28 850	*22 900	*22 900	*17 850	16 550			*15 800	15 050	8.06
-4.5 m	kg					*22 350	*22 350	*17 550	*17 550					*14 600	*14 600	6.76

Boom – 7.0 m

Coupler – N/A

Bucket – None

Stick – M2.57 m

Shoes – 750 mm double grouser (HD)

Load Point Height	kg	1.5 m		3.0 m		4.5 m		6.0 m		7.5 m		9.0 m		m		
		Front	Side	Front	Side	Front	Side	Front	Side	Front	Side	Front	Side	Front	Side	
9.0 m	kg													*16 700	*16 700	6.82
7.5 m	kg									*17 200	*17 200			*15 700	*15 700	8.00
6.0 m	kg							*20 600	*20 600	*17 800	*17 800			*15 450	14 650	8.77
4.5 m	kg							*23 200	*23 200	*19 000	18 250	*16 700	13 750	*15 750	13 150	9.23
3.0 m	kg							*25 550	24 200	*20 250	17 500	*17 150	13 350	*16 500	12 450	9.43
1.5 m	kg							*26 800	23 250	*21 000	16 900	*17 400	13 050	*16 650	12 300	9.38
Ground Line	kg					*26 950	*26 950	*26 650	22 850	*21 050	16 550	*17 000	12 900	*16 750	12 750	9.08
-1.5 m	kg					*31 500	*31 500	*25 100	22 850	*19 900	16 500			*16 750	13 950	8.50
-3.0 m	kg			*31 000	*31 000	*27 100	*27 100	*21 900	*21 900	*16 650	*16 650			*16 250	*16 250	7.59
-4.5 m	kg					*19 700	*19 700	*15 150	*15 150					*14 350	*14 350	6.18

*Indicates that the load is limited by hydraulic lifting capacity rather than tipping load. The above loads are in compliance with hydraulic excavator lift capacity standard ISO 10567:2007. They do not exceed 87% of hydraulic lifting capacity or 75% of tipping load. Weight of all lifting accessories must be deducted from the above lifting capacities. Lifting capacities are based on the machine standing on a firm, uniform supporting surface.

Always refer to the appropriate Operation and Maintenance Manual for specific product information.

374D L Bucket Specifications and Compatibility

	Linkage	Width	Capacity	Weight	Fill Factor	Reach Boom 7.8 m				ME Boom 7.0 m	
		mm	m ³	kg	%	R2.8VB2	R3.6VB2	R4.15VB2	R4.6VB2	M2.6WB2	M3.0WB2
Pin-On											
General Duty (GD)	VB2	1900	3.8	3622	100%	●	◎	○	○		
	WB2	2000	4.6	4016	100%					●	◎
	WB2	2100	5.0	4167	100%					◎	◎
Heavy Duty (HD)	VB2	1900	3.8	3782	100%	●	◎	○	⊗		
	WB2	2100	5.0	4345	100%					●	◎
	WB2	2250	5.3	4591	100%					◎	◎
Severe Duty (SD)	WB2	1800	3.7	4667	90%					●	●
	WB2	1900	4.0	4825	90%					●	●
	WB2	2000	4.4	4982	90%					●	◎
	WB2	2100	4.6	5141	90%					◎	◎
	WB2	2200	5.0	5341	90%					◎	○
Extreme Duty (XD)	WB2	2000	4.4	5785	90%					◎	○
	WB2	2100	4.6	5982	90%					◎	○
	WB2	2200	5.0	6212	90%					○	⊗
Maximum dynamic load pin-on (payload + bucket)					kg	10 650	9610	8860	8070	12 150	11 260

With Quick Coupler (CW-70)

General Duty (GD)	VB2	1900	3.8	3668	100%	◎	○	⊗	⊗		
Severe Duty (SD)	WB2	1900	4.0	4802	90%					◎	◎
	WB2	2000	4.4	4959	90%					◎	○
Extreme Duty (XD)	WB2	2000	4.4	5797	90%					○	⊗
Maximum dynamic load with CW coupler (payload + bucket)					kg	9330	8290	7540	6750	10 830	9940

The above figures are based on maximum recommended dynamic working weights with front linkage fully extended at ground line with bucket curled. They do not exceed a stability ratio of 1.25.

Capacity based on ISO 7451.

Bucket weights include General Duty tips.

- 1800 kg/m³ or greater
- ◎ 1500 kg/m³ or less
- 1200 kg/m³ or less
- ⊗ Not Recommended

Work Tools Matching Guide

When choosing between various work tool models that can be installed onto the same machine configuration, consider work tool application, productivity requirements, and durability. Refer to work tool specifications for application recommendations and productivity information.

		Without Quick Coupler						With Quick Coupler CW-70					
		Reach Boom				ME Boom		Reach Boom				ME Boom	
Linkage		VB	VB	VB	VB	WB	WB	VB	VB	VB	VB	WB	WB
Stick length – mm		2840	3600	4150	4670	2570	3000	2840	3600	4150	4670	2570	3000
Ripper	TR70, TR70 short			N	N					N	N		
Multi-processor	MP40	CC, CR									N	N	N
		PS, S									N	N	N
Crusher	P360											N	N
Shear	S365B									N	N		N
Hammer	H180S							N		N	N	N	N

360° Working Range

N = Not Recommended

374D L Standard Equipment

Standard equipment may vary. Consult your Cat dealer for details.

ELECTRICAL

Alternator – 75 ampere
Lights
Cab interior
Cab lights, halogen, time delay
Boom lights, halogen
Signal/warning horn

ENGINE/POWER TRAIN

Automatic engine speed control
Automatic swing parking brake
Automatic travel parking brakes
Cat® C15 with ACERT® Technology
Altitude capability to 2300 m
Electric fuel priming pump
High ambient cooling capability
Side-by-side cooling system with separately mounted AC condenser and variable speed fan
Two speed travel
Water separator, with level indicator, for fuel line

GUARDS

Heavy duty bottom guards on upper frame
Heavy duty swivel guard on undercarriage
Heavy duty travel motor guards on undercarriage

OPERATOR STATION

Air conditioner, heater and defroster with automatic climate control
Ashtray and 24 volt lighter
Beverage/cup holder
Coat hook
Console mounted electronic type joysticks with adjustable gain and response
Floor mat
Instrument panel and gauges with full color graphical display
Literature compartment
Neutral lever (lock out) for all controls
Positive filtered ventilation
Pressurized cab
Retractable seat belt 50 mm width
Sunshade for windshield and skylight
Travel control pedals with removable hand levers
Windshield wipers and washers (upper and lower)

UNDERCARRIAGE

Grease lubricated PPR2 tracks
Hydraulic track adjusters
Long, variable gauge
Steps – four

OTHER STANDARD EQUIPMENT

Auxiliary hydraulic valve for hydro-mechanical tools
Cast idlers
Cat one key security system with locks for doors, cab and fuel cap
Catwalks – left side and right side
Cross-roller type swing bearing
Drive for auxiliary pump
Mirrors – left and right
S·O·SSM quick sampling valves for engine oil and hydraulic oil
Steel firewall between engine and hydraulic pumps
Product Link and rearview camera (EU only)

Optional equipment may vary. Consult your Cat dealer for details.

FRONT LINKAGE

Booms

- Mass excavation 7.0 m with two working lights
- Reach 7.8 m with two working lights

Sticks

- M2.57WB for mass boom
- M3.0WB for mass boom
- R2.84VB for reach boom
- R3.6VB for reach boom
- R4.15VB for reach boom
- R4.67VB for reach boom

Bucket Linkages

- VB2-family for VB2 sticks (available with or without lifting eye)
- WB2-family for WB2 sticks (available with or without lifting eye)

Buckets – see chart

Tips, sidecutters and edge protectors

TRACK

- Double grouser 650 mm
- Double grouser 750 mm
- Double grouser 900 mm

GUARDS

- FOGS (Falling Object Guard System) including overhead and windshield guards
- Track guiding guards
 - Full length
 - Center section
- Wire mesh screen for windshield

AUXILIARY CONTROLS AND LINES

- Basic control arrangements
 - Single action – one-way high pressure for hammer application
 - Combined function – function for one-way or two-way high pressure
- Quick coupler circuit
- Quick coupler lines for booms
- Quick coupler lines for sticks
- Auxiliary boom lines
 - High pressure for reach and mass booms
- Auxiliary stick lines
 - High pressure lines for reach and mass sticks

MISCELLANEOUS OPTIONS

- Adjustable high-back seat with mechanical suspension
- Adjustable high-back, heated seat with air suspension
- Boom lowering control device with SmartBoom™
- Starting aid for cold weather with ether
- Stick lowering control device
- Straight travel pedal
- Cab front rain protector
- Converter, 10 amp – 12 volt with two sockets
- Electric refueling pump
- HID, boom lights
- HID, cab lights, time delay
- Jump start terminals
- Reversible cooling fan including protective screen
- Operator Compartment
 - Joysticks
 - Four button joystick for standard machine or single action auxiliary control
 - Thumb wheel modulation joystick for use with combined auxiliary control
- Radio
 - AM/FM radio mounted in right hand console with antenna and two speakers
 - Radio ready mounting at rear location including 24 volt to 12 volt converter speakers, antenna
 - Two-way radio ready
- Windshield
 - 70-30 split, sliding, one-piece, fixed
- WAVS ready
- BIO Oil package
- Travel alarm

374D L Hydraulic Excavator

For more complete information on Cat products, dealer services, and industry solutions, visit us on the web at www.cat.com

© 2010 Caterpillar Inc.
All rights reserved

Materials and specifications are subject to change without notice. Featured machines in photos may include additional equipment. See your Cat dealer for available options.

CAT, CATERPILLAR, SAFETY.CAT.COM, their respective logos, "Caterpillar Yellow" and the "Power Edge" trade dress, as well as corporate and product identity used herein, are trademarks of Caterpillar and may not be used without permission.

HEHH4376 (07-2010)

