

SENEBOGEN[®]

Green Line

Vorsprung durch Innovation

Leading through Innovation



- ❑ **Material-Umschlagmaschine - Recycling, Schrott, Hafen, Holz**
- ❑ **Material Handling Machine - recycling, scrap, port, timber**



1957 Kohleumschlag
Coal handling



1954 Dunglader S 500
S 500 manure loader



1953 Laden von Mist
Loading of dung



1968
Erhöhte Fahrerkabine hochgesetzte
Auslegeranlenkpunkte
High operator's cab
Elevated boom pivotal point



1965
Hydraulischer Bagger im
Schrottschlag
Hydraulic excavator in scrap
handling



1964
Schrottschlag
Scrap handling



1969
Erhöhte Fahrerkabine Spezial
Umschlagausrüstung
High operator's cab Specific material
handling equipment



1970
Vollhydraulischer Seilbagger als
stationäre Umschlagmaschine
Fully hydraulic rope excavator as pedestal
handling machine



1976
Vollhydraulischer Mobil Kran mit
hochfahrbarer Kabine
Fully hydraulic wheeled crane
Hydraulically elevated cab



1978
Holzumschlag in Sibirien / CIS
(Ust Ilimsk) Tiefsttemperaturen
bis -40°C, erhöhte Kabine, fester spezial
Holzgreifer
Timber handling in Siberia / CIS (Ust Ilimsk)
Deep temperature use up to -40°C
High cab, special timber grab



1979
Innovation:
24 t Mobilumschlaggerät, Reichweite
12,5 m, Spezial-SENNEBOGEN Achsen
mit 3 m Breite für exzellente Stabilität.
Innovation:
SENNEBOGEN wide gauge-axes 3 m
width for excellent stability 24 t mobile
handling machine 12,5 m action radius



1982
Stationäre Umschlagmaschine mit
einer Reichweite von 15 m.
Pedestal machine
Actionradius 15 m.



1986
Innovation:
Für den stationären Materialumschlag
entwickelt SENNEBOGEN extrem lange
Ausleger für 20 m Reichweite. Eine echte
Pionierleistung die die Entwicklung maß-
geblich beeinflusst.

Innovation:
Boom with 20 m action radius ! To ensure
a more effective material handling,
SENNEBOGEN already developed already
1986 extremely long handling attach-
ments.

Materialumschlag Materials Handling



2005

Innovation:
Die neue 7er Serie für den Holzumschlag feiert Premiere

Innovation:
Introducing of the new 7 series for timber handling



2002

Innovation:
Die neue "green line" Serie C wird vorgestellt

Innovation:
Introducing of the new „green line„ C series



2001

Innovation:
Mit der Entwicklung des 870 green line definiert SENNEBOGEN neue Dimensionen im Materialumschlag. Große Reichweiten, exzellente Leistung bei niedrigem Verbrauch, hohe Traglasten, unglaubliche Flexibilität. Kurz gesagt: ausgezeichnete Kundennutzen.

Innovation:
With the design of the 870 SENNEBOGEN defines new dimensions in the field of materials handling. Wide product variation offers maximum customer's benefit.



1996

Innovation:
SENNEBOGEN bündelt seine gesamte, langjährige Erfahrung und kreiert in Verbindung mit Kundenanforderungen eine völlig neue Reihe von Hochleistungs Material Umschlaggeräten - Die "green line" Serie wird geboren.

Innovation:
SENNEBOGEN combines its long lasting know-how in the field of materials handling and develops the new „green line" product line on the basis of customer- & market requirements.



1995

Raupen Umschlagmaschine mit erhöhter starrer Kabine

Crawler handling machine high cab, fixed



1992

Mobile 36 t Umschlagmaschine mit 3 m SENNEBOGEN Spezial Breitspurachsen

36 t rubber tired material handling machine with SENNEBOGEN special wide gauge-axles 3 m



1987

Innovation:
Im Rahmen der Kooperation mit Hanomag entwickelt SENNEBOGEN eine spezielle 3-teilige Umschlag-Ausrüstung für einen Großauftrag der US-Army.

Innovation:
Within the scope of the co-operation with Hanomag, SENNEBOGEN developed a special three-piece boom for a bulk order of the US Army.



1989

Stationäre Umschlagmaschine, 20 m Umschlagausrüstung, Elastiklager, zum Schutz der Maschine, Elektroantrieb

Stationary machine 20 m handling equipment, elastic swing bearing, mounting protection for the machine-Electrodrive



1990

Innovation:
SENNEBOGEN liefert den ersten SR28 speziell, eine echte Innovation und wegweisende Entwicklung für den modernen effektiven Materialumschlag.

Innovation:
SENNEBOGEN delivers the first SR 28 special - for the first time the advantages of a risen pedestal machine are combined with the mobility of a crawler machine.



1990

Aufbau Materialumschlagmaschine. Zwischenrahmen mit Schiebeträger-Abstützung

Truck mounted materials handling machine. Intermediate frame with stabilisers

Die neue D-Serie - einfach besser

D-Serie



Überlegene Arbeitsgeschwindigkeiten
Superior speeds



Unterwagen - neue, überlegene
Konstruktion, neueste HD-Achsenteknik
Undercarriage - completely redesigned
construction, latest HD axle technology



Oberwagen - bequem und sicher erreichbar
bar
Upper carriage - comfortable and safe
entering and exiting

Gebaut aus unseren stärksten Ideen

Built from our strongest ideas



**Komplett neues Auslegersystem
und Kinematik** - extra starker Ausleger mit
extra großen Lagerstellen für Dauer-
Höchstleistungseinsatz
**Completely new boom system
and kinematics** - heavy-duty boom with
extra large bearings for permanent
high-performance operation

The new D-Series - simply better

D-Series



Großer Rahmenquerschnitt – vom Ausleger bis zum Ballast
Large frame cross-section - from boom to counterweight



Starker, dynamischer Drehantrieb für schnelle Arbeitsspiele
Strong, dynamic swing drive for fast working cycles



Völlig neu entwickelter Oberwagen
Completely redesigned upper structure

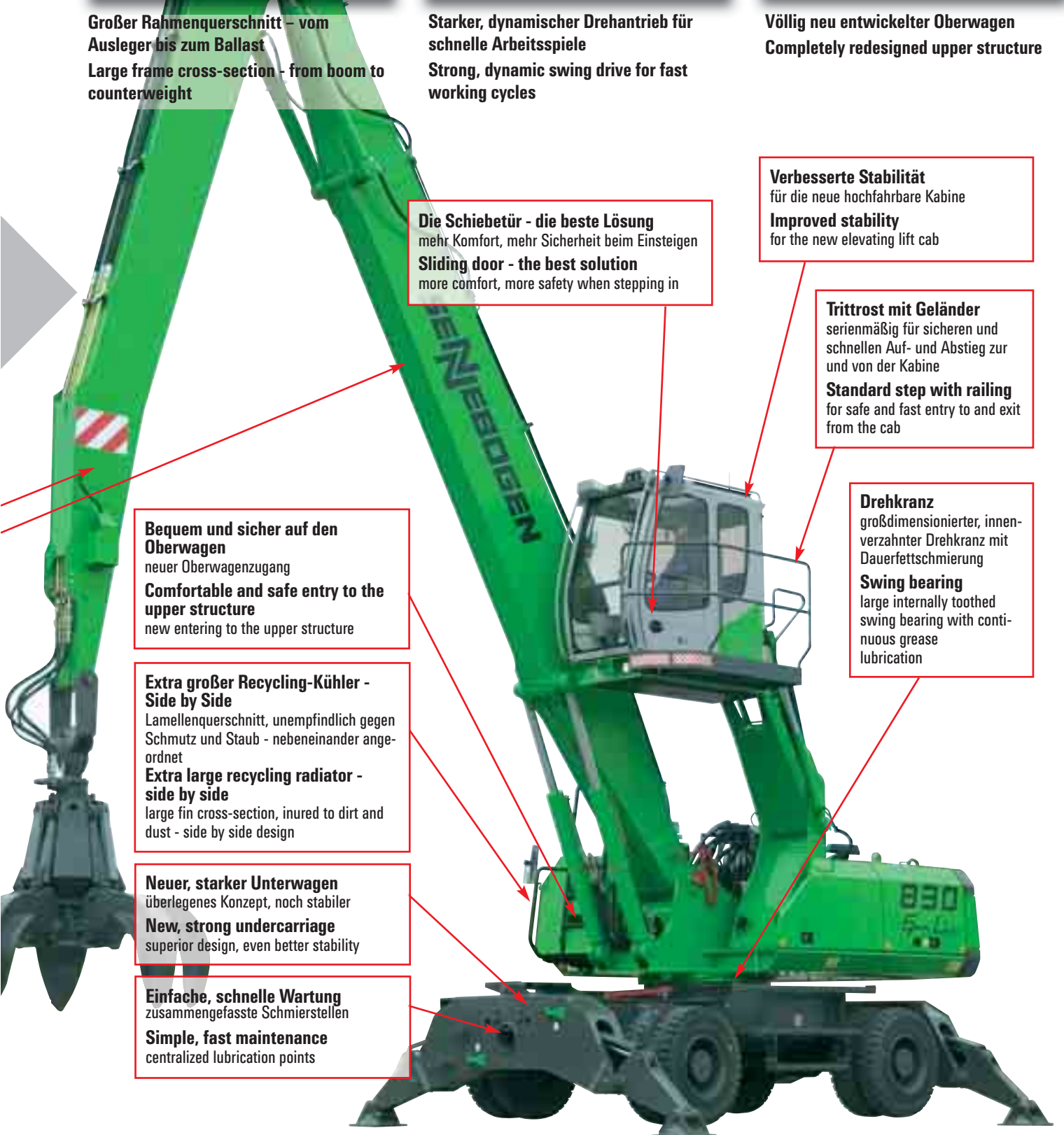

Die Schiebetür - die beste Lösung
 mehr Komfort, mehr Sicherheit beim Einsteigen
Sliding door - the best solution
 more comfort, more safety when stepping in

Verbesserte Stabilität
 für die neue hochfahrbare Kabine
Improved stability
 for the new elevating lift cab

Trittrost mit Geländer
 serienmäßig für sicheren und schnellen Auf- und Abstieg zur und von der Kabine
Standard step with railing
 for safe and fast entry to and exit from the cab

Drehkranz
 großdimensionierter, innenverzählter Drehkranz mit Dauerfettschmierung
Swing bearing
 large internally toothed swing bearing with continuous grease lubrication

Bequem und sicher auf den Oberwagen
 neuer Oberwagenzugang
Comfortable and safe entry to the upper structure
 new entering to the upper structure

Extra großer Recycling-Kühler - Side by Side
 Lamellenquerschnitt, unempfindlich gegen Schmutz und Staub - nebeneinander angeordnet
Extra large recycling radiator - side by side
 large fin cross-section, inured to dirt and dust - side by side design

Neuer, starker Unterwagen
 überlegenes Konzept, noch stabiler
New, strong undercarriage
 superior design, even better stability

Einfache, schnelle Wartung
 zusammengefasste Schmierstellen
Simple, fast maintenance
 centralized lubrication points

Die neue green line D-Serie ist da!

D-Serie



Die Kühlbox mit 3-Kreis-Kühlsystem für Ladeluft-, Wasser- und Ölkühlung
The cool box with 3-circuit cooling system for charge air, water and oil cooling



Hervorragende Zugänglichkeit zu den Batterien und Luftfilter
Excellent access to the batteries and air filter



Täglicher Service bequem und schnell vom Boden aus
Daily service comfortable and fast from the ground

Pure Leistung Pure power



Servicefreundlich
zentrale Anordnung der Servohydraulikventile
Service-friendly
central arrangement of the servo-hydraulic valves

Batterietrennschalter
und Hauptsicherungen
Battery main switch
and main fuses

The new green line D-Series is available!

D-Series



Zentrale Messpunkte zur einfachen und schnellen Überprüfung der gesamten Hydraulikanlage
Central measuring points for simple and quick inspection of the entire hydraulic system



Übersichtlicher Elektroverteiler mit klarer und deutlicher Beschriftung – leichte und schnelle Fehlerdiagnose
Clearly organised electrical distribution with distinct labeling - easy and quick trouble shooting



Reduzierter Serviceaufwand durch zentral zusammengeführte Schmierpunkte
Reduced service requirements because of centralised lubrication points

Servicefreundlich

Täglicher Service bequem und schnell vom Boden aus

Service-friendly

Daily service comfortable and fast from the ground

SENNEBOGEN HydroClean

schützt die Hydraulikkomponenten - senkt Wartungs- und Reparaturkosten

SENNEBOGEN HydroClean

protects the hydraulic components, reduces maintenance and repair costs

Starker 6-Zylinder Diesel-Motor in TIER III Technologie

Strong 6-cylinder diesel engine in TIER III technology

Kühlbox

Die Kühler sind nebeneinander Side by Side angeordnet – keine Verschmutzung zwischen den Kühlern

Cool box

Radiators are arranged side by side - no contamination between the radiators

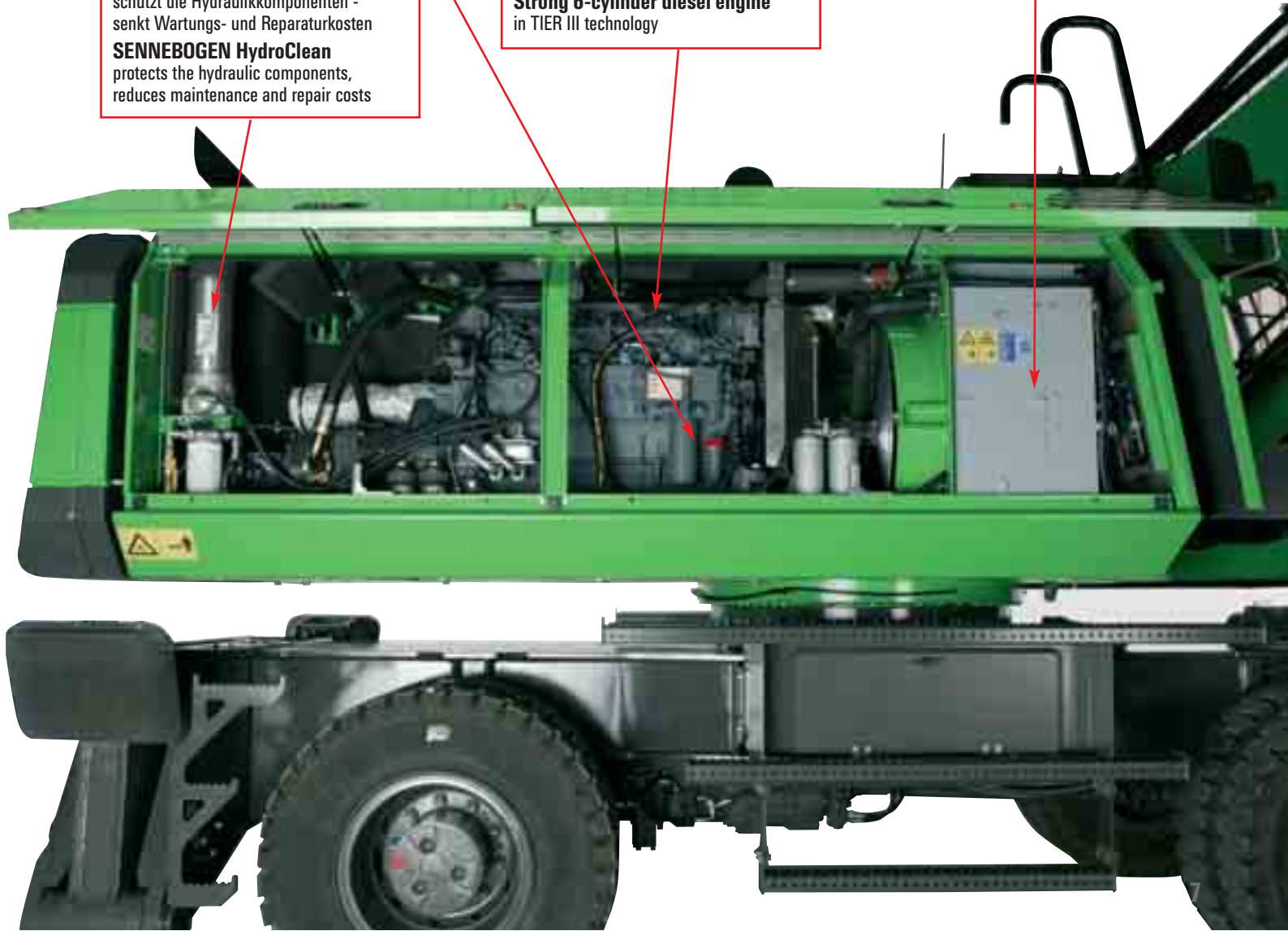

green line Materialumschlagmaschinen von SENNEBOGEN

Profi-Geräte für Profis!

Die Philosophie:

Materialumschlag ist Hochleistung - deshalb sind Hochleistungsmaschinen die richtige Antwort.

SENNEBOGEN hat mit der "green line" Serie eine völlig neue Generation von Materialumschlagmaschinen entwickelt.

Es wurden keine Serien Erdbewegungsbagger modifiziert.

Die Aufgabe ist die kompromißlose Konzentration auf den Materialumschlag.

Das Ergebnis - leistungsstarke, robuste Geräte die sich überall dort wo Materialien, Stückgüter und Schüttgüter aller Art umgeschlagen, entladen, sortiert aber auch zerkleinert werden müssen, bestens bewähren.

Fragen Sie uns - wir beraten Sie gerne!

Green Line

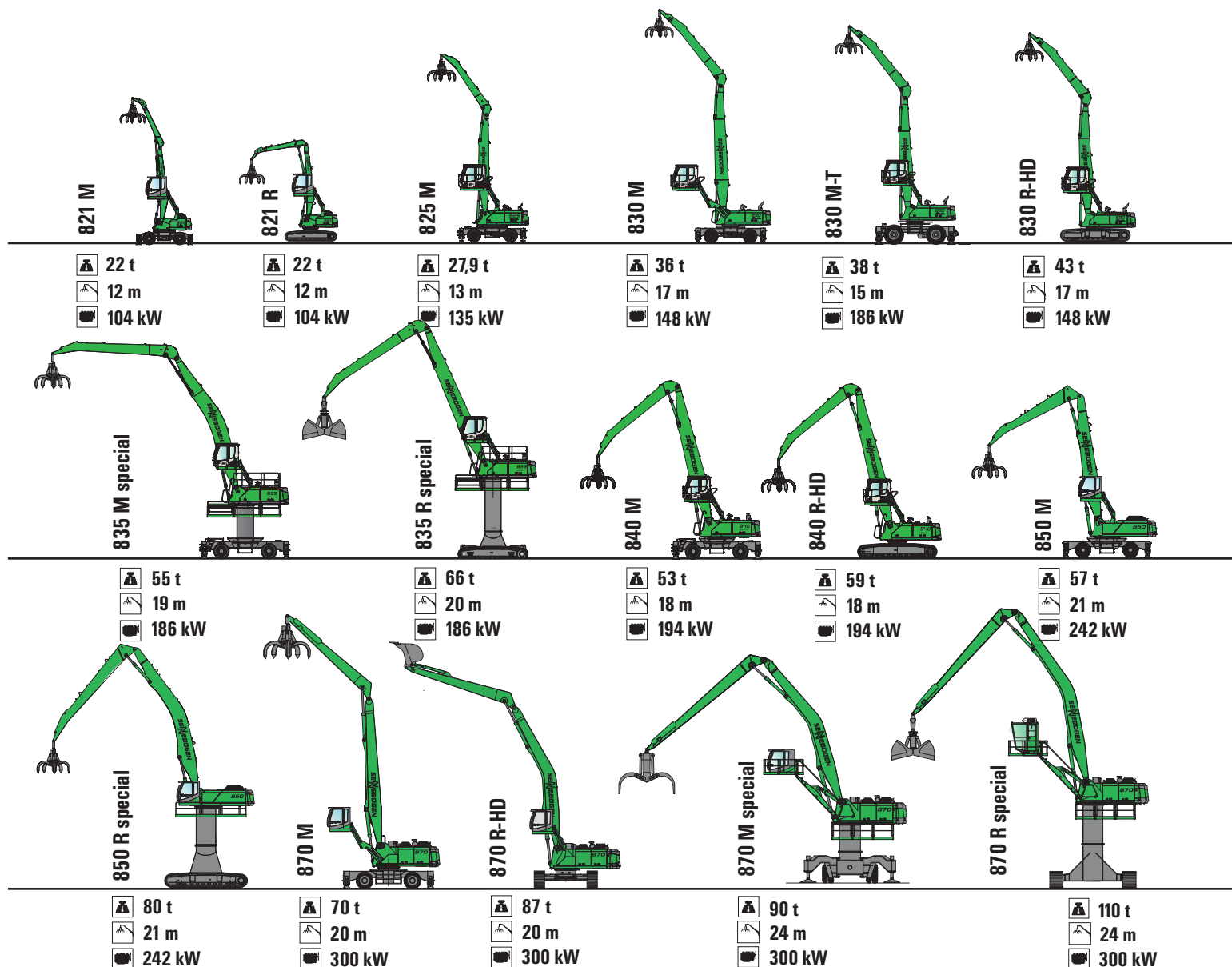

SENNEBOGEN green line Materials Handling Machines

Professional tools for Professionals!

The Philosophy:

Materials handling is hard work – That's why heavy duty machines are the right answer.

With the "green line" series, SENNEBOGEN has designed and developed a completely new generation of materials handling machines.

They are no modifications of series-production earthmoving excavators.

They have been designed to focus uncompromisingly on materials handling.

The result: Powerful rugged machines that are proving extremely worthwhile wherever it comes to handling, unloading, sorting or even breaking up of materials, general cargo and bulk material of any kind.

Get in touch with us – We are pleased to advise you!

Green Line

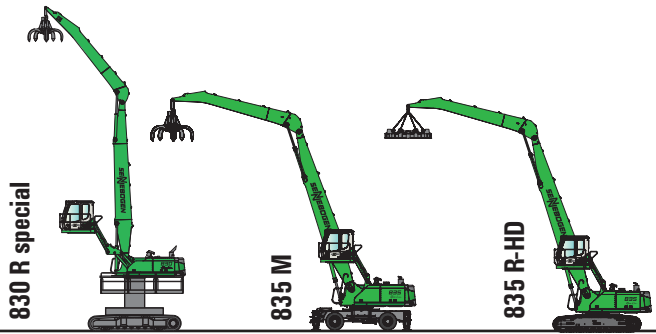

830 R special

835 M

835 R-HD

47 t
17 m
148 kW

44 t
18 m
186 kW

54 t
18 m
186 kW



723 M-HD

730 M-HD

735 M-HD

22 t
10,5 m
112 kW

30 t
11 m
148 kW

38,5 t
11,3 m
186 kW

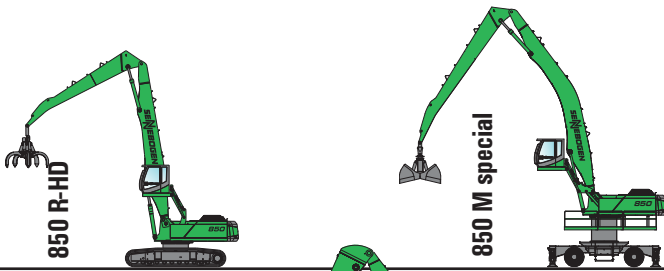

850 R-HD

850 M special

70 t
21 m
242 kW

60 t
21 m
242 kW

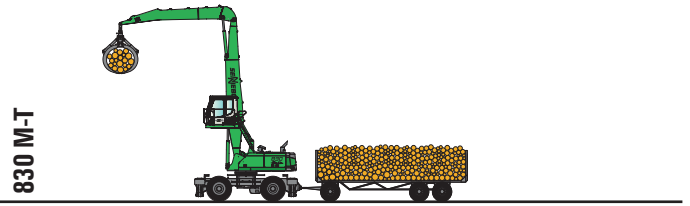

830 M-T

38 t
15,3 m
186 kW

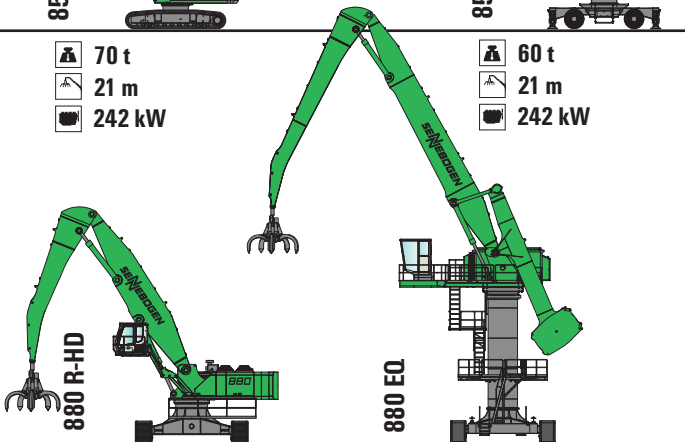

880 R-HD

880 EQ

150-180 t
26 m
570 kW

215-270 t
33 m
470 kW



305 Multihandler

305 XL Multihandler

5000 kg
7,3 m
91 kW

5000 kg
9,0 m
91 kW

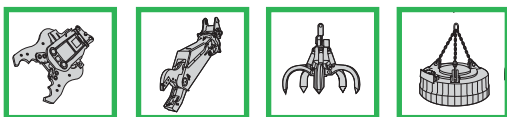

Green Line

Schrottschlag / Stahlwerke
Scrap Handling



825 M



821 M



840 M

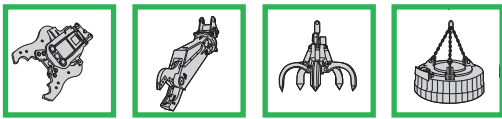

Schrottschlag / Stahlwerke
Scrap Handling



830 R-HD



850 R special electro



830 M D-Serie



830 R D-Serie

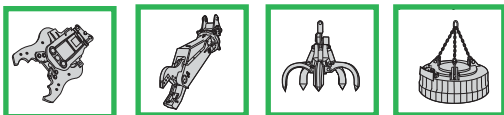

Green Line

Schrottschlag / Stahlwerke
Scrap Handling



835 A special



835 M



850 M

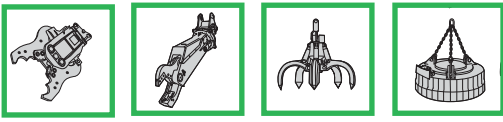

SENEBOGEN[®]

Schrottschlag / Stahlwerke
Scrap Handling



825 M



850 A special electro



830 M D-Serie Vario-Tool

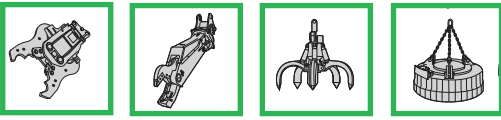

Green Line

Schrottschlag / Stahlwerke
Scrap Handling



880 EQ



870 R special

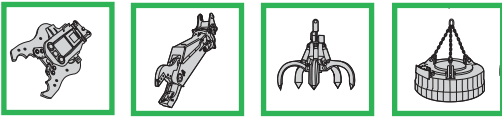

Schrottschlag / Stahlwerke
Scrap Handling



825 M



850 M



835 R-HD



Green Line

Holz- / Forstwirtschaft
Timber Handling / Logging



735 M-HD



723 M-HD



735 M-HD



Holz-/ Forstwirtschaft
Timber Handling / Logging



730 M-HD



735 M-HD



723 M-HD

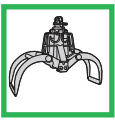

Green Line

Holz-/ Forstwirtschaft
Timber Handling / Logging



835 M



835 M-HD



835 A special

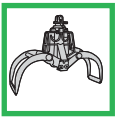

Holz- / Forstwirtschaft
Timber Handling / Logging



723 M-HD



830 M-HD

835 R-HD

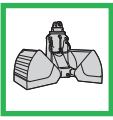

Green Line

Sand- und Kiesumschlag
Sand and Gravel



835 M



870 R-HD



850 M



850 M

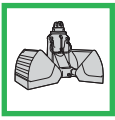

Sand- und Kiesumschlag
Sand and Gravel



870 A



850 R-HD



870 R-HD

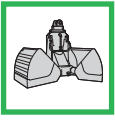

Green Line

Sand- und Kiesumschlag
Sand and Gravel



870 M special



850 M special



835 R-HD electro

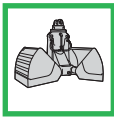

Hafenumschlag Port Handling



850 M special



850 R-HD



870 R special

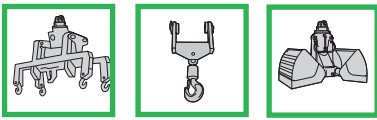

Green Line

**Hafenumschlag
Port Handling**



830 A



835 R special



870 M special



880 EQ

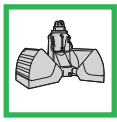
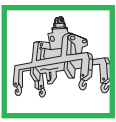

**Hafenumschlag
Port Handling**



870 A special



870 M special



870 R special

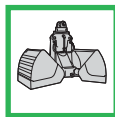
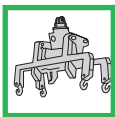

Green Line

**Hafenumschlag
Port Handling**



835 M



870 R special



835 M special

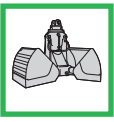
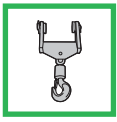
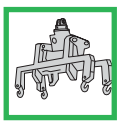

**Hafenumschlag
Port Handling**



870 M special



835 A



870 R special

850 M



Hafenumschlag Port Handling



835 M



835 M



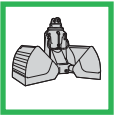

**Hafenumschlag
Port Handling**



880 R



880 R



880 EQ



880 EQ



Green Line

**Hafenumschlag
Port Handling**



880 EQ



880 EQ



880 EQ



Abfall / Recycling / Umwelttechnik
Recycling / Waste Handling



825 M



821 M



821 M



Green Line

Abfall / Recycling / Umwelttechnik
Recycling / Waste Handling



825 M D-Serie



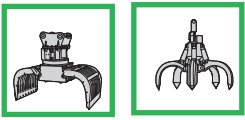

Abfall / Recycling / Umwelttechnik
Recycling / Waste Handling



821 M



821 M



821 M



Green Line

Multihandler



305 Multihandler





Multihandler



305 Multihandler



305 Multihandler

Neue Großraum-Komfortkabine mit Schiebetür

New king-sized comfort cabin with sliding door

MAX CAB

Luftgefederter Komfortsitz

mehrfach verstellbar mit Bandscheibenstütze und Sitzheizung, einstellbare Armlehnen

Air suspended comfort seat

adjustable with lumbar support and seat heating, adjustable armrests



Schiebetür

erleichtert sicheres und bequemes Ein- und Aussteigen

Sliding door

simplified and safe access to the operator's cab



Hydraulisch hochfahrbare Kabine

mit getöntem Sicherheitsglas, hydraulisch gedämpft und schwingungsgedämpft gelagert

Hydraulically elevating cab

with safety glass tinted, hydraulically damped, resiliently mounted



SENNEBOGEN Diagnostic-System

zur Überwachung aller wichtigen Maschinen- und Motorfunktionen

SENNEBOGEN Diagnostic system

for monitoring of all essential machine and engine functions

Beste Ergonomie

Sitz individuell zu den Steuerhebeln und separat zu den Fußpedalen einstellbar

Best ergonomics

ergonomic operator's seat, individually adjustable in height and angle for optimum working environment and operator's comfort



Trittrost mit Geländer

serienmäßig = Sicherheit beim Auf- und Abstieg

Step with railing

standard - safety in entering and exiting



Heiz-Klimaautomatik

mit Temperatursteuerung, 8 einstellbare Lüfterdüsen sorgen für wohliges Klima, starke Defrosterfunktion, Frischluft/ Umluftsteuerung mit Partikelfilter

Automatic regulation

of heating and air condition according temperature setting, 8 adjustable air vents provide excellent defrosting, air/circulation function, particle filter for outside and circulation air

SENNEBOGEN Maschinenfabrik GmbH
Hebelstrasse 30 · D-94315 Straubing

Tel: +49 (0) 94 21/5 40-144/146/150

Fax: +49 (0) 94 21/4 3882

E-Mail: marketing@sennebogen.de

» www.sennebogen.com