

305C+ *MULTIHANDLER*

pure Energie
pure power



5.000 kg



9 m



SENEBOGEN[®]

Motor	
Hersteller/Typ	Deutz TCD2012L042V - TIER III
Leistung	91 kW/124 PS
Kühlung	wassergekühlt
Nenn-Drehzahl	2200 min⁻¹
Kraftstofftankinhalt	290 l
Elektrische Anlage	24 V
Batterien	2x 110 Ah
Hydraulikanlage	
Fahrwerksantrieb im geschlossenen Kreislauf über Axialkolben-Verstellpumpe	
	0-165 l/min
<ul style="list-style-type: none"> - Sehr feinfühliges, automotives Fahren - Vorwahl über Fahrtrichtungsschalter - Drehzahlabhängige Verstellung der Fahrpumpe und des Axialkolbenregelmotors - Inch-Bremspedal 	
Arbeitsfunktionen über Load-Sensing-Pumpe mit Nullhubregelung	
	0-200 l/min
<ul style="list-style-type: none"> - Durch die unabhängige, proportionale Zuteilung der Pumpenmenge können mehrere Arbeitsfunktionen gleichzeitig und unabhängig voneinander präzise gesteuert werden - Nebenfunktionen über Zahnradpumpe - 1-Hebel-Bedienung für Arbeitsbewegungen 	
Hydrauliktankinhalt	95 l
Fahrwerk	
Fahrtrieb	Allradantrieb und Allradlenkung, Fahrtrieb stufenlos über die neue Variospeed hydrostatik Antriebseinheit
Bremsanlage	2-Kreis Servo Bremsanlage und Sicherheits-Parkbremse, federbelastet
Bereifung	Luftreifen 4 fach wahlweise: Industriereifen, Luftreifen ausgeschäumt, Vollgummireifen
Geschwindigkeit	0-25 km/h Variospeed (0-20 km/h mit TÜV-Zulassung)

Chassis
<ul style="list-style-type: none"> - Stabile Schweißkonstruktion, verwindungssteif und präzisionsbearbeitet - Starke, verwindungssteife Anbindung der hochfahrbaren Kabine - Starke, robuste Kotflügel
Arbeitsausrüstung
<ul style="list-style-type: none"> - 2-teiliger Teleskopausleger, besonders stark mit großem Querschnitt - Spezielle Gleitführungen an den Profillecken zur optimalen Krafteinleitung - Starker, innenliegender Teleskopierzylinder - Wippzylinder und Teleskopzylinder mit Rohrbruchsicherheitsventil - Starker hydraulischer Schnellwechsler - Zusatzhydraulikkreis ZH1 - Permanente Auslastungsanzeige
Fahreerkabine
<ul style="list-style-type: none"> - Serienmäßig hydraulisch hochfahrbar - Komfortfahreerkabine elastisch gelagert mit Superschalldämmung - Allwetterausführung - Rundumverglasung aus Sicherheitsglas - Großes Dachfenster - Komfortsitz elastisch gelagert, gewichtseinstellbar, schwingungsgedämpft - Übersichtliches Armaturentableau, schwenkbare Lenksäule - Stufenlos regelbare Kabinenheizung mit Umluftstufe und Partikel-Filter
Einsatzgewicht
305 Multihandler in Serienausführung mit Schnellwechselplatte und Hubgabel
ca. 11.500 kg
Die angegebenen Gewichte können sich durch verschiedene Ausstattungen verändern! Technische Änderungen vorbehalten!

Wendekreis /turning radius

3 Lenkungsarten / 3 steering modes

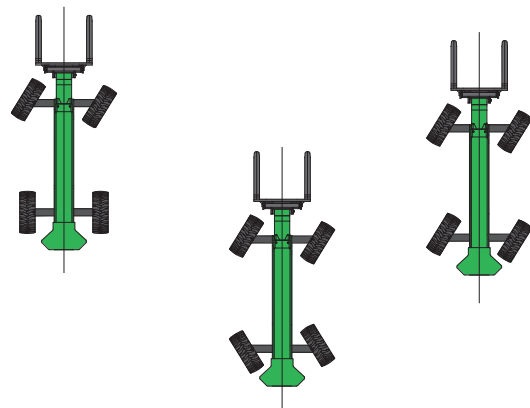
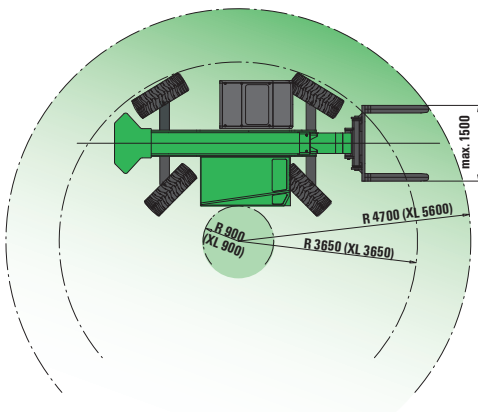

engine

manufacturer/type	Deutz TCD2012L042V - TIER III
engine output	91 kW/124 HP
cooling system	water-cooled
nominal rpm	2200 min ⁻¹
fuel tank capacity	290 l
electric System	24 V
batteries	2 x 110 Ah

hydraulic system

drive system in closed loop circuit through variable displacement piston pump	0-165 l/min
<ul style="list-style-type: none"> - very precise, automotive drive motion - pre selector of driving direction - speed related regulation of the drive pump and the variable axial piston motor - inch-braking pedal 	

working functions through load-sensing pump with flow on demand control

	0-200 l/min
<ul style="list-style-type: none"> - through the independent and proportional feed of the oil flow, all working functions can be operated in a simultaneous, independent and very precise way - secondary functions through gear pump - single Servo-joy stick control for working functions 	
hydraulic tank capacity	95 l

drive System

drive	all wheel drive and all wheel steering, drive system stepless through the new variespeed hydrostatic drive unit
brake System	2-circuit servo brake system and safety parking brake, spring loaded
tires	4 air tires, optional: industrial tires, foam filled tires, solid rubber tires
speed	0-25 km/h variespeed (0-20 km/h according german road regulations)

chassis

- stable welded construction in rigid design, precision machined
- strong, torsion resistant connection of the hydraulic elevating cab
- strong, robust fenders

working equipment

- 2-section telescopic boom, extra strong with a large profile
- special sliding shoes for optimised force transmission
- telescopic cylinder inside the boom
- boom hoist and telescopic cylinder are equipped with safety check valves
- strong hydraulic quick coupler
- additional hydraulic circuit ZH1
- continuous load control

operator's cap

- hydraulic elevating and tilting cab in Series
- comfortable, resiliently mounted operator's cab with exceptional sound suppression
- all-weather design with safety glass
- large size skylights
- comfortable seat, resiliently mounted, adjustable in suspension
- clearly laid out instrument panel, adjustable steering column
- variable cab heating system, outside air and circulating air stage with particle filter

service weight

305 Multihandler in standard configuration with quick coupler and lifting forks	ca. 11,500 kg
the shown weights may vary with different equipment! Subject to technical modification!	

Variospeed

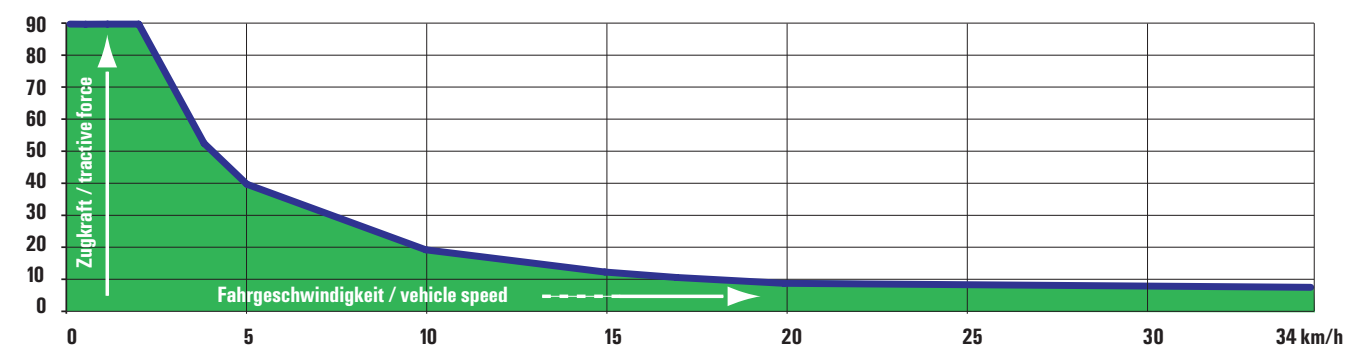

- **Fahrtrieb stufenlos über die neue Variospeed Antriebseinheit**
- **Immer die optimale Kombination aus Kraft und Geschwindigkeit**
- **Automotives, feinfühliges Fahren**
- **drive system stepless through the new variespeed drive unit**
- **the best combination of force and speed at any time**
- **automotive, precises drive motion**

Arbeitsbereich und Traglasten mit Hubgabel working area and rated loads with forks

80 % der Kipplast
80 % of tipping load

305

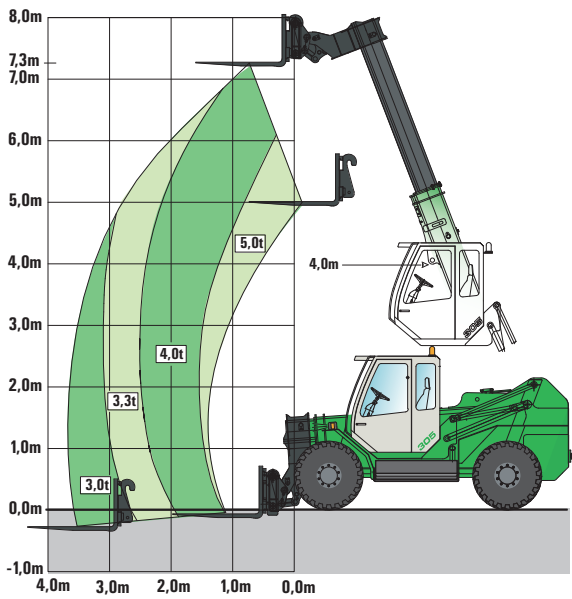

80 % der Kipplast
80 % of tipping load

305 XL

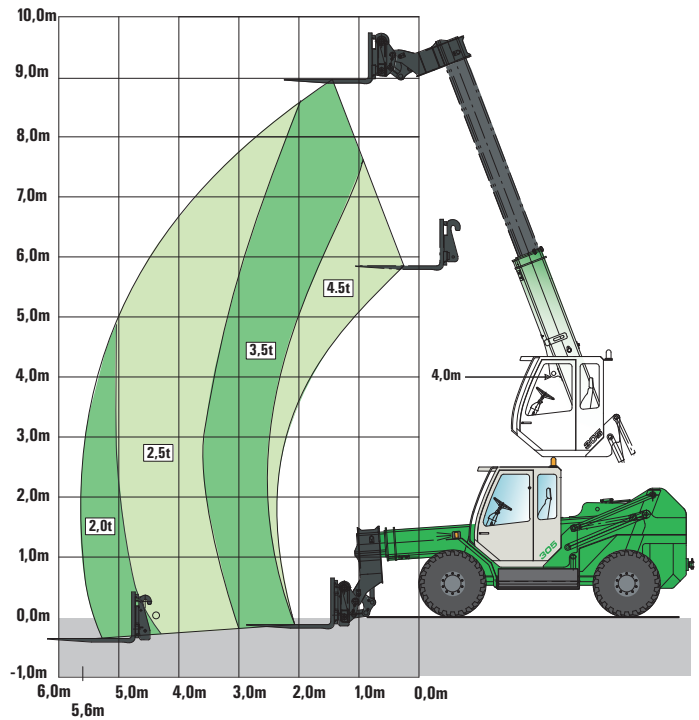

Maße dimensions

*ca. 2700 mm mit Zusatzscheinwerfer und Rundumleuchten gültig mit Bereifung 425/75R20

*approx. 2700 mm with additional lights and rotating beacon in combination with tyres 425/75/R20

Alle Maße metrisch in Meter/Millimeter
Maße unterliegen Toleranzen und Ausstattungsmerkmalen und können abweichen!

All measures in metric meters/millimeter
Measures are depending on tolerances and variable attachments and may differ!

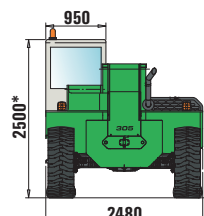
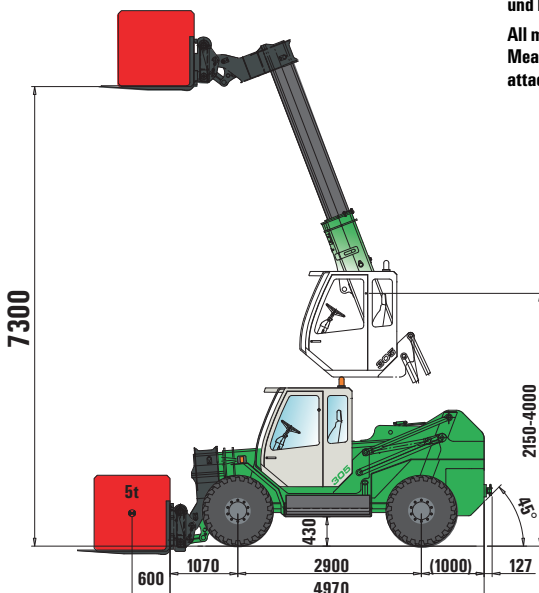

Anmerkungen:

1. Die angegebenen Traglastwerte gelten für ebenen und festen Stand der Maschine.
2. Die Traglastwerte entsprechen ISO 8313 und überschreiten nicht die im jeweiligen Diagramm angegebene Standsicherheit.
3. Die Traglastwerte gelten für mittig platzierte Last auf der Hubgabel bei Schwerpunktsabstand von 600 mm ab Gabelträger.
4. Das Gewicht der Lastaufnahmemittel (Haken, Gehänge) ist von den Traglasten abzuziehen.
5. Lastwerte müssen begrenzt oder vermindert werden, um ungünstige Bedingungen zu berücksichtigen, wie weichen oder unebenen Boden, Gefälle, Wind, Seitenlasten, schwingende Lasten, Rucken oder plötzliches Stoppen der Ladungen, Unerfahrenheit des Personals, Fahren mit Last.

Arbeitsbereich und Traglasten mit Schaufel working area and rated loads with bucket

50 % der Kipplast
50 % of tipping load

305

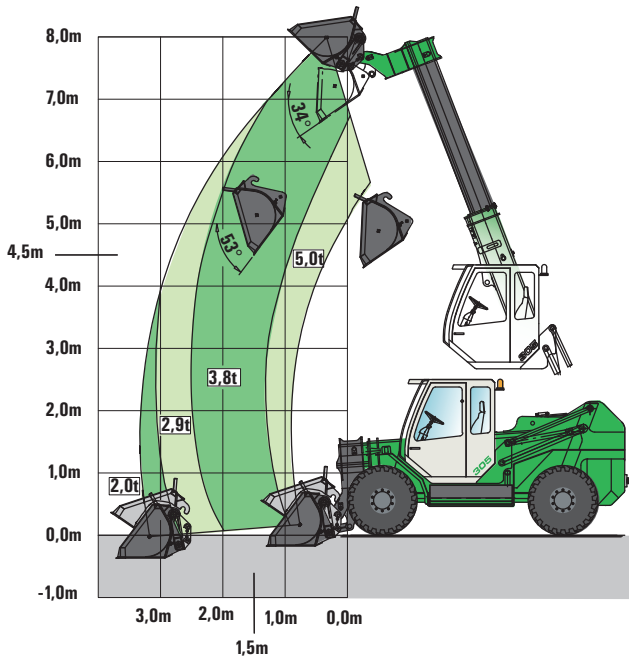

50 % der Kipplast
50 % of tipping load

305 XL

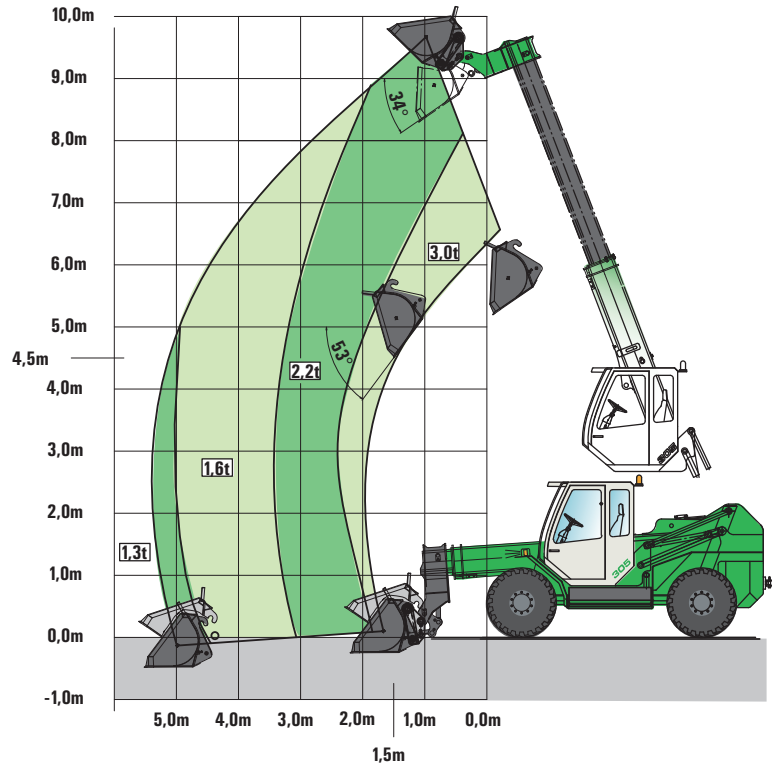

Maße XL dimensions XL

*ca. 2700 mm mit Zusatzscheinwerfer und Rundleuchten gültig mit Bereifung 425/75R20
*approx. 2700 mm with additional lights and rotating beacon in combination with tyres 425/75/R20

Alle Maße metrisch in Meter/Millimeter
Maße unterliegen Toleranzen und Ausstattungsmerkmalen und können abweichen!

All measures in metric meters/millimeter
Measures are depending on tolerances and variable attachments and may differ!

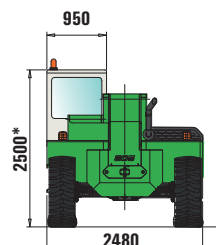
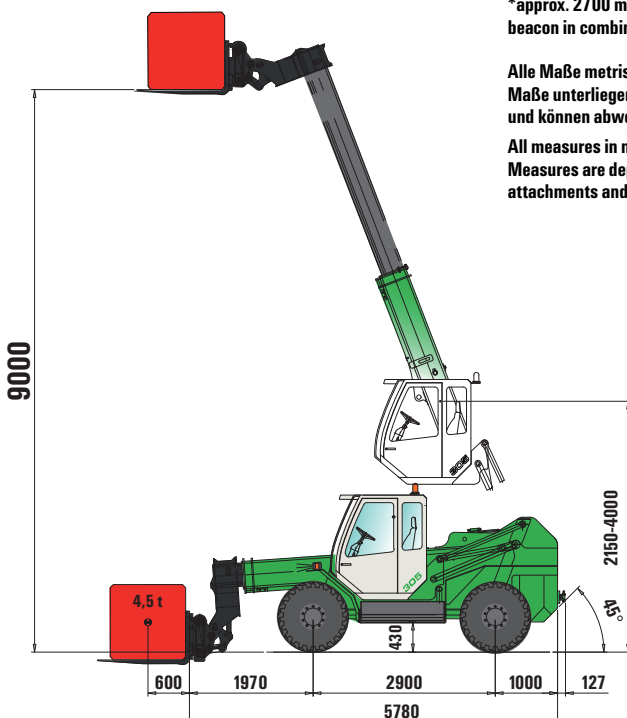

notes:

1. the rated loads shown are based on the machine in firm level ground
2. the rated loads are based on ISO 8313 and do not exceed the safety factors indicated in the respective diagram.
3. the rated loads are valid for centred positioned load on the lifting forks with a centre of gravity distance of 600 mm from the fork carrier.
4. the rated loads shown include the weight of all lifting attachments, such as hook and bucket.
5. the users must derate or limit the lifted loads to allow for adverse conditions, wind, side loads, pendulum action, jerking or sudden stopping of loads, inexperience of personnel and travelling with a load.

Der neue SENNEBOGEN 305 Multihandler mit C+ Technik- die superstarke Materialumschlagmaschine für Recycling, Industrie, Bau und Landwirtschaft



Der perfekte Arbeitsplatz mit überlegener Ergonomie

- Komfort-Großraumkabine
- Sehr bequemer Einstieg
- 1-Hebel-Bedienung und verstellbare Lenksäule

the perfect workplace with outstanding ergonomics

- large, comfortable cabin with superb visibility
- easy to board
- single joystick control and adjustable steering column



Flexibel, einfach und schnell bereit für jeden Einsatz

- Hydraulische Schnellwechsellinrichtung in besonders schwerer Ausführung
- Ausgezeichnete Parallelführung der Arbeitsgeräte mit Umlenkmechanismus
- Ein Zusatzhydraulikkreis serienmäßig, optional 2. Kreis

flexible, simple and quick to set up for any job

- hydraulic quick coupling system in extra heavy duty design
- excellent parallel guidance of the operating attachment with reversing mechanism
- one auxiliary hydraulic circuit as standard, optionally 2nd circuit



Schneller und besser durch reduzierte Wartungskosten

- Servicefreundlich mit sehr guter Zugänglichkeit
- Lange Serviceintervalle
- Grobschmutzabscheidung durch Feinstgitter
- Schwingungsentkoppeltes Lüftersystem und Lüfterumkehrschaltung (optional)

faster and better thanks to reduced maintenance costs

- excellent service accessibility
- extended maintenance intervals
- coarse particle separation via superfine grill
- fan reverse circuit to blow out the cooler (optional)

the new SENNEBOGEN 305 Multihandler with C+ technics – the super-tough materials handling machine for recycling, industry, construction and farming

Fahrtrieb mit innovativem Konzept

- Automotives Fahren im geschlossenen Hydraulikkreislauf
- Allradantrieb und Allradlenkung
- beste Manövrierfähigkeit durch kleinen Wenderadius
- stufenloser Antrieb - immer optimale Fahrleistung

drive system with innovative concept

- automotive drive in closed loop hydraulic circuit
- all wheel drive and all wheel steering
- best maneuverability through reduced turning circle
- stepless drive motion - best combination of speed and force



Der souveräne Überblick aus 4 m Höhe

- Beste Rundumsicht bei 4 m Augenhöhe
- Hydraulisch stufenlos hochfahrbar mit beruhigender Stabilität
- Überlegene Technik für mehr Leistung und Sicherheit



superior visibility from a height of 4 m

- excellent visibility at 4 m eye level
- hydraulic step-free adjustment with reliable stability
- outstanding design for increased performance and safety

Starkes Hydrauliksystem

- Axialkolbenpumpe im geschlossenen Hydraulikkreislauf für Fahren
- Load Sensing Hydrauliksystem mit separater Axialkolbenpumpe für Arbeitsfunktionen
- schnelle, kraftvolle Arbeitszyklen durch die sehr großdimensionierte Hydraulikanlage

powerful hydraulic system

- swash plate piston pump in closed loop circuit for driving
- load sensing hydraulic system with axial piston pump for working functions
- fast and powerful working cycles through the very large sized hydraulic system



Die optimale Kombination von Radlader und Telehandler

- **Bessere Übersicht und Sicherheit**
- **Bessere Beladung durch Materialverdichtung**
- **Bessere Manövriermöglichkeit durch Allradlenkung**
- **Schnelle Arbeitsspiele durch Variospeed**

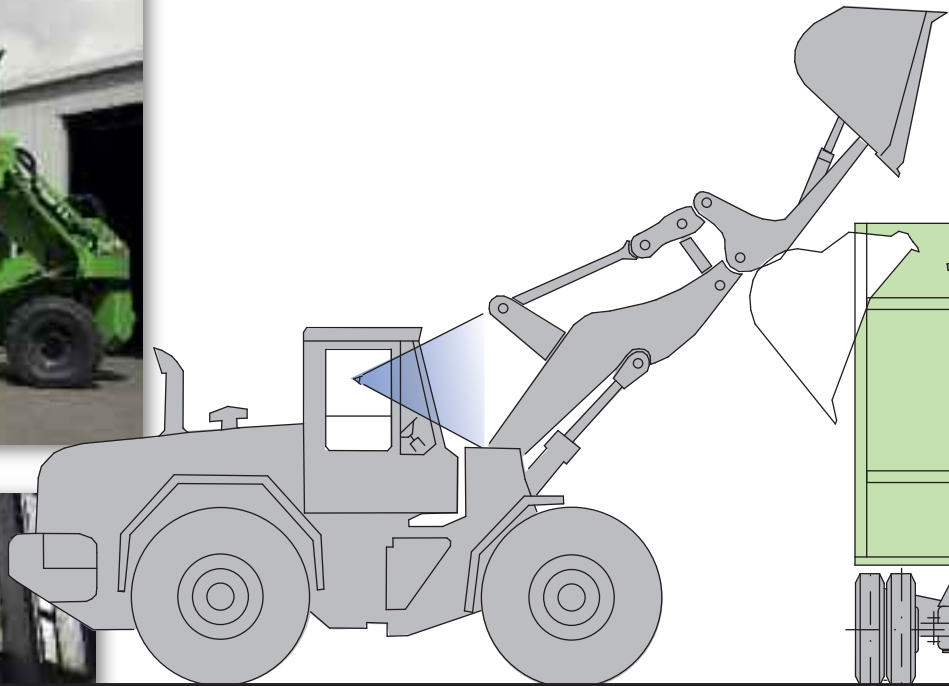

the optimum combination of wheel loader and telehandler

- better overview and safety
- better loading through compaction of material
- better maneuverability through all wheel steering
- fast cycle times through variespeed

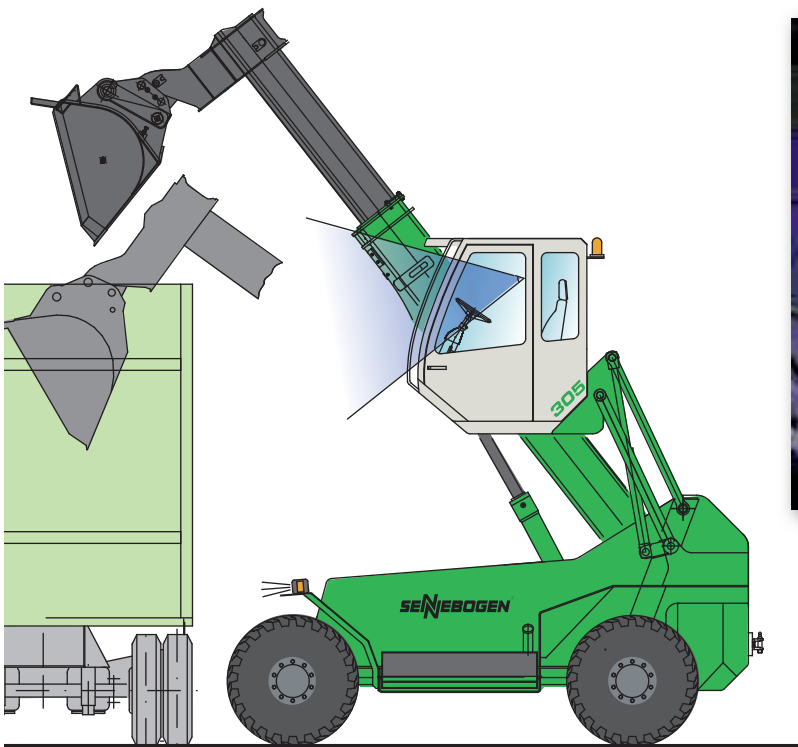

Anbaugeräte working equipment



Leichtgutschaufel

rehand bucket for light material



Sperrgutschaufel mit
hydraulischem Greifarm
bulk good bucket with
hydraulic gripper



Erdschaufel ohne oder mit Zähne
earth bucket with/without teeth



Gabelzinkenverstellgerät 5.000 kg

fork positioner with sideshift 5,000 kg



Holzgreifer mit hydraulischen Greifarmen

timber grab with hydraulic gripper

Reifen tires



Luftreifen

air tire



Industriereifen

industrial tires



Vollgummireifen

solid rubber tires



Kranausleger - starr

crane boom - fixed



Mehrschalengreifer

orange peel grab



Kehrmaschine

road sweeper



Holzgreifer

timber grab



Hubgabel 5.000 kg

lifting fork 5,000 kg



Arbeitsplattform -starr

working platform - fixed



Schneeräumschild

snow mine-sweeping shield



Hubwinde mit Tragrahmen

hoisting winch with supporting frame

Be- bzw. Entladen eines LKWs loading / unloading of trucks and trailers

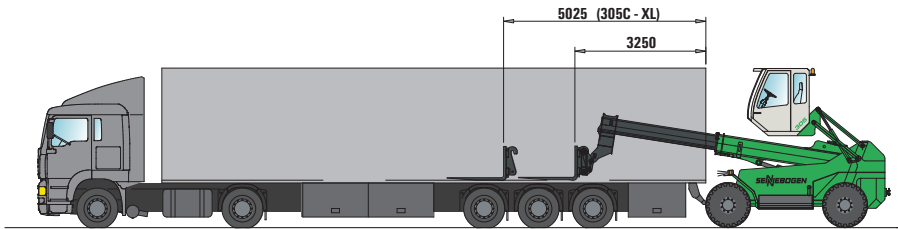

**305 C+ - großer Arbeitsbereich
und ausgezeichnete Sicht
= exzellente Sicherheit!**

**305 C+ - large working area
and best visibility
= excellent safety!**

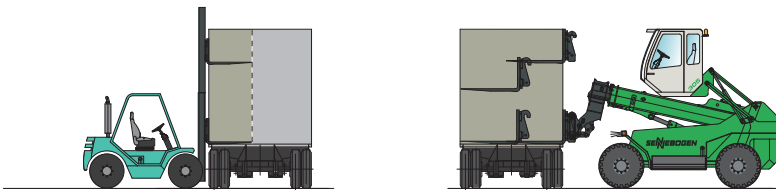





Vorsprung durch Innovation Leading through Innovation

SENNEBOGEN Maschinenfabrik GmbH
Hebbelstrasse 30 · D-94315 Straubing
Tel: +49(0)94 21/5 40-146 Fax: 4 38 82
E-Mail: greenline@sennebogen.de

Technische Änderungen ohne Vorankündigung und Verpflichtung gegenüber früher gelieferten Geräten vorbehalten!
Die abgebildeten Geräte können Sonderausrüstungen haben! Irrtum und Druckfehler vorbehalten.
Technical specifications are subject to change without notice and without incurring responsibility for machines previously sold! The shown machines may have special equipment! Error and misprints reserved.

www.sennebogen.com