

Solmec



- 100 LS
- 200 ESC
- 300 ESC**
- 400 ESC
- 500 ESC



HANDLING MACHINE SERIES 300 ESC (Electronic Synchron Control)

Solmec handling machines are designed and built using the best materials and components available on the market in order to guarantee reliability, performances, safety, and high residual value.

Each machine is an innovation that reinterprets the previous model and that improves its technical features.

The 300 ESC series involves three versions. The first, 311ESC, has a gooseneck boom and a telescopic or straight stick, very useful to move quickly on wheels with a very good stability and load capacity.

The second has, 313ESC, has a straight boom and an industrial straight stick, ideal for who needs a compact machine with a big reach.

The third, 313ESC, has a straight boom and a selector arm as stick, perfect to work on waste selecting and recycling.

While planning this series 300 ESC, preference was given to obtain fast and reliable machines with small running costs and easy to transport. The diesel engine more powerful of the category, able to produce high torque with low rpm, permits to work fast and silently already at 75% of rpm. As a consequence it is possible to have very low fuel costs and long life of the engine.

Big productivity, maximum reliability, together with little fuel consumption, make of the 300 ESC series machine, the most profitable in the category of the medium handling machine.



The engine cover Easy access to the engine and components simplifies servicing. Internal special soundproofing covers made of polyurethane foam with a very thin sheet of lead that retains noise. Slots for air exchange turned on the top so to avoid air and noise directly on the operator.

Hydraulic oil tank pressurized with air filtration system.

Nitrogen charged accumulators increase movements fluidity and operator's comfort.

Centralized automatic greasing system (as standard), to make easier service operations.

Large radiators, fitted side by side, so to simplify cleaning, and built of aluminium with coarse-mesh to allow a better thermic exchange avoiding occlusion of air passages. On request it is possible to fit a reversible fan with automatic timer to clean radiators for 20 seconds each working hour without operator's action.



Operators cabin with hydraulic parallelogram elevation has a 5,2 m high reach (operator's eye), and permits always a safety distance of the load content in the grab. It is possible, on request, to have a vertical elevation system, and, with a 50 cm fixed extension, permit the operator's eye to reach 4,7 m.

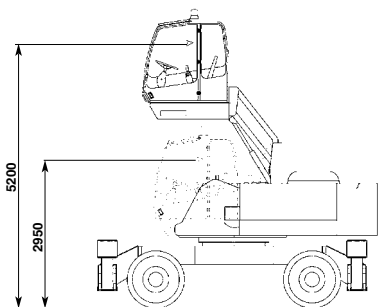

Parallelogram hydraulic **cabin**.

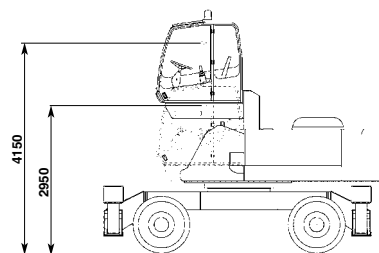

Vertical hydraulic **cabin**.



Operators cabin with big windows for a better visibility. The front window, with double wiper, opens, completely disappearing under the top of the cab. A rotating orange light, standard fitted, on the top of the cab guarantee a good visibility also during the darker hours of the day. It is possible, as option, to fit extra working lights on stick and on the undercarriage to increase visibility. As option it is possible to fit a front window screen or a total protection of the cab.

Undercarriage with large double rows ball bearing slew ring, and ballast blocks fitted on the centre of the frame to drop the centre of gravity, increasing the stability of the machine in any working condition.





COMFORT SERIES 300 ESC (Electronic Synchron Control)

The clear visual **instrumentation panel** allows monitoring of all machines functions also all information concerning the engine, battery voltage, fuel level, diagnostic codes, hydraulic system, liquids levels and temperatures. There are also controls dedicated to auxiliary functions and for light warnings that advise the operator when air or hydraulic oil filters are congested, or when the machine reaches stability level, highness of the grab from the ground or distance of it from the centre of the machine, total or partial hour counter, hours from the next service, list of controls for auxiliary functions. As option, it is possible to fit a GPRS system to make immediately any information available to be controlled.



Display

Keyboard

Comfortable drive

Sprung, extra large seat with 10 regulation modalities, safety seat belt with winding mechanism, adjustable arms, headrest, and seat heating. In addition, an integrated safety device to turn on machine controls only when the operator is in driving position and the safety arm rest is in the down position.

Standard air conditioner

With 5 vents to cool the air in the cab and to dehumidify it, avoiding windows steaming up. Heating winter and summer ventilation device are standard fitted.

Radio



The new 300 series can stand up to any comparison

311 ESC

All technology at operator's service

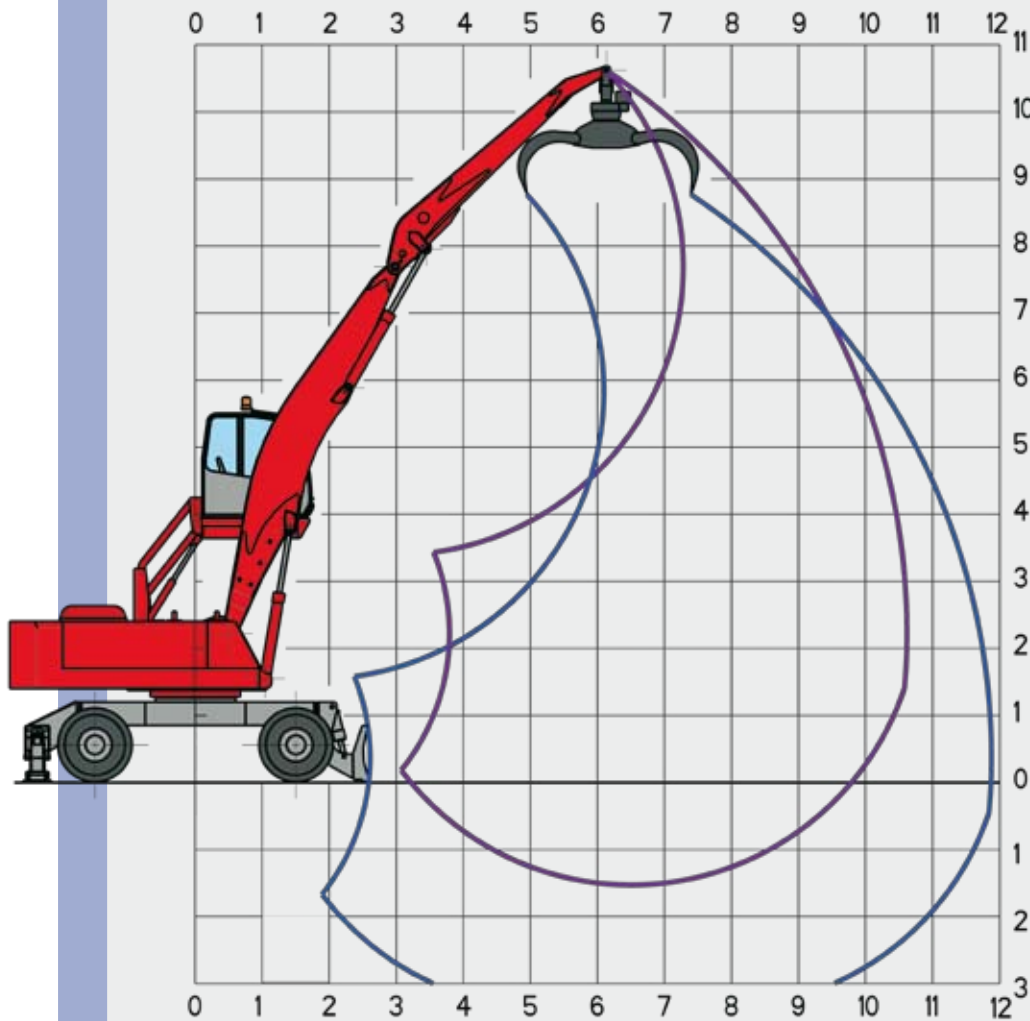

WORKING DIAGRAM FOR LOGS' HANDLING

Gooseneck boom
6.00 m

Straight Industrial Stick
4.30 m

On request
telescopic stick
3.40 m - 4.40 m

SUGGESTED GRABS FOR LOGS

MODEL	WITH CROSSED TEETH			WITH SIMPLE CLOSING TEETH	
	SR 220	SHU 520 S	SR 260	S 2400	S 3000
OPENING (m)	2,16	2,30	2,62	2,40	3,00
AREA (m ²)	0,60	0,52	0,8	1,25	1,60
WEIGHT WITHOUT ROTATOR (kg)	800	420	1000	1020	1110

LIFTING CAPACITIES TONS

LIFTING RANGE (m)

HEIGHT METRES	CONFIGURATION	4.0			6.0			8.0			10.0			10.4		
		↖	○	⊙	↖	○	⊙	↖	○	⊙	↖	○	⊙	↖	○	⊙
10.0	○○															
	┃┃															
	┃┃┃															
8.0	○○							6,20*	4,27	3,20						
	┃┃							6,20*	6,20*	5,03						
	┃┃┃							6,20*	6,20*	5,39						
6.0	○○							6,24*	4,24	3,18	3,81*	2,91	2,19			
	┃┃							6,24*	6,24*	5,01	3,81*	3,81*	3,32			
	┃┃┃							6,24*	6,24*	5,43	3,81*	3,81*	3,32			
4.0	○○				8,25*	6,16	4,62	6,50	4,08	3,06	4,69	2,91	2,18			
	┃┃				8,25*	8,25*	7,18	6,65*	6,50	4,87	5,69*	4,69	3,51			
	┃┃┃				8,25*	8,25*	7,18	6,65*	6,65*	5,78	5,69*	5,69*	4,32			
2.0	○○	11,71*	9,63	7,22	9,38	5,68	4,26	6,29	3,87	2,91	4,61	2,84	2,13	4,20	2,57	1,93
	┃┃	11,71*	11,71*	10,19	9,49*	9,37	7,03	7,15*	6,28	4,71	5,77*	4,61	3,46	4,23*	4,20	3,15
	┃┃┃	11,71*	11,71*	10,19	9,49*	9,49*	8,26	7,15*	7,15*	5,82	5,77*	5,68	4,26	4,23*	4,23*	3,68
0	○○	6,62*	6,62*	5,76	8,98	5,33	4,00	6,11	3,71	2,78						
	┃┃	6,62*	6,62*	5,76	10,16*	8,97	6,73	7,38*	6,10	4,58						
	┃┃┃	6,62*	6,62*	5,76	10,16*	10,16*	8,47	7,38*	7,38*	5,67						

- ↖ LIFTING CAPACITIES ON LONGITUDINAL AXIS
- LIFTING CAPACITIES ON 360° WITHOUT SAFETY FACTOR
- ⊙ LIFTING CAPACITIES ON 360° ACCORDING WITH ISO 10567 STANDARD

* = HYDRAULIC LIMIT
 LIFTING CAPACITIES ARE ON HOOK WITHOUT GRABS, MACHINE STATIC, LEVEL SOLID GROUND, WITH AXLE LOCKED.
 OPERATING WEIGHT WITH BLADE, OUTRIGGERS, FULL RUBBER TYRES, GOOSENECK BOOM 6.00 m, TELESCOPIC STICK, SR 220 GRAB WITH ROTATOR.

DIMENSIONS

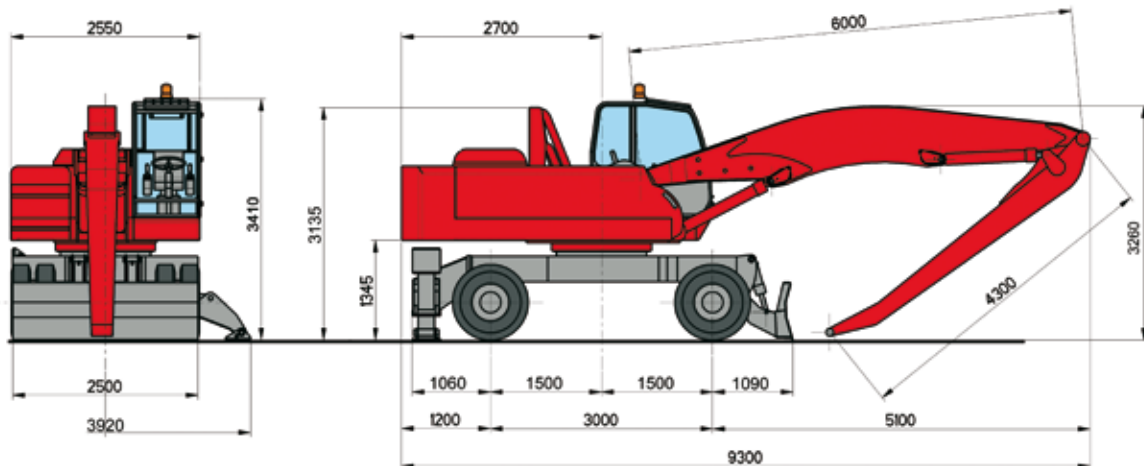

OPERATING WEIGHT 28.900 KG

The new 300 series can stand up to any comparison

311 ESC

All technology at operator's service

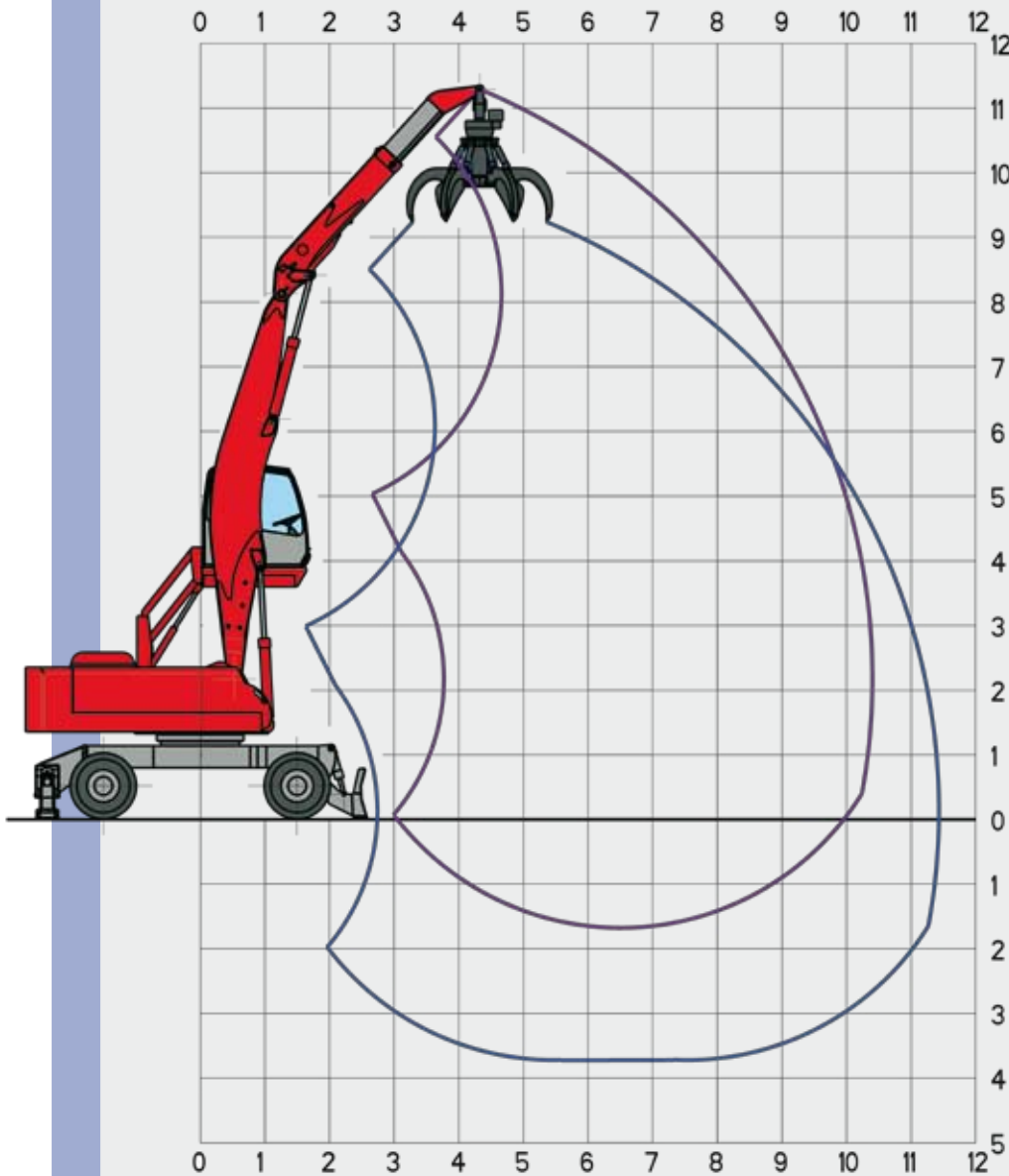

WORKING DIAGRAM FOR SCRAP HANDLING

Gooseneck boom
6.00 m

Straight Industrial Stick
4.30 m

On request
telescopic stick
3.40 m - 4.40 m

SUGGESTED ORANGE PEEL GRABS

MODEL	FOR SCRAP		FOR WASTE
	SRV 505	SRV 605	SRR 805
OPENING (m)	1,93	2,11	2,20
CAPACITY (l)	500	600	800
WEIGHT WITHOUT ROTATOR (kg)	1050	1490	1200

LIFTING CAPACITIES TONS

LIFTING RANGE (m)

HEIGHT METRES	CONFIGURATION	4.0			6.0			8.0			10.0			10.4		
		↖	○	⊙	↖	○	⊙	↖	○	⊙	↖	○	⊙	↖	○	⊙
10.0	○○				7,31*	6,57	4,93									
	┌┐				7,31*	7,31*	6,36									
	└└				7,31*	7,31*	6,36									
8.0	○○				6,83*	6,72	5,04	6,20*	4,27	3,20						
	┌┐				6,83*	6,83*	5,94	6,20*	6,20*	5,03						
	└└				6,83*	6,83*	5,94	6,20*	6,20*	5,39						
6.0	○○	8,68*	8,68*	7,56	7,22*	6,55	4,92	6,24*	4,24	3,18	3,81*	2,91	2,19			
	┌┐	8,68*	8,68*	7,56	7,22*	7,22*	6,28	6,24*	6,24*	5,01	3,81*	3,81*	3,32			
	└└	8,68*	8,68*	7,56	7,22*	7,22*	6,28	6,24*	6,24*	5,43	3,81*	3,81*	3,32			
4.0	○○	11,62*	11,62*	8,26	8,25*	6,16	4,62	6,50	4,08	3,06	4,69	2,91	2,18			
	┌┐	11,62*	11,62*	10,11	8,25*	8,25*	7,18	6,65*	6,50	4,87	5,69*	4,69	3,51			
	└└	11,62*	11,62*	10,11	8,25*	8,25*	7,18	6,65*	6,65*	5,78	5,69*	5,69*	4,32			
2.0	○○	11,71*	9,63	7,22	9,38	5,68	4,26	6,29	3,87	2,91	4,61	2,84	2,13	4,20	2,57	1,93
	┌┐	11,71*	11,71*	10,19	9,49*	9,37	7,03	7,15*	6,28	4,71	5,77*	4,61	3,46	4,23*	4,20	3,15
	└└	11,71*	11,71*	10,19	9,49*	9,49*	8,26	7,15*	7,15*	5,82	5,77*	5,68	4,26	4,23*	4,23*	3,68
0	○○	6,62*	6,62*	5,76	8,98	5,33	4,00	6,11	3,71	2,78						
	┌┐	6,62*	6,62*	5,76	10,16*	8,97	6,73	7,38*	6,10	4,58						
	└└	6,62*	6,62*	5,76	10,16*	10,16*	8,47	7,38*	7,38*	5,67						

- ↖ LIFTING CAPACITIES ON LONGITUDINAL AXIS
- LIFTING CAPACITIES ON 360° WITHOUT SAFETY FACTOR
- ⊙ LIFTING CAPACITIES ON 360° ACCORDING WITH ISO 10567 STANDARD

* = HYDRAULIC LIMIT

LIFTING CAPACITIES ARE ON HOOK WITHOUT GRABS, MACHINE STATIC, LEVEL SOLID GROUND, WITH AXLE LOCKED.

OPERATING WEIGHT WITH BLADE, OUTRIGGERS, FULL RUBBER TYRES, GOOSENECK BOOM 6.00 m, TELESCOPIC STICK, SRV 605 ORANGE PEEL GRAB WITH ROTATOR.

DIMENSIONS

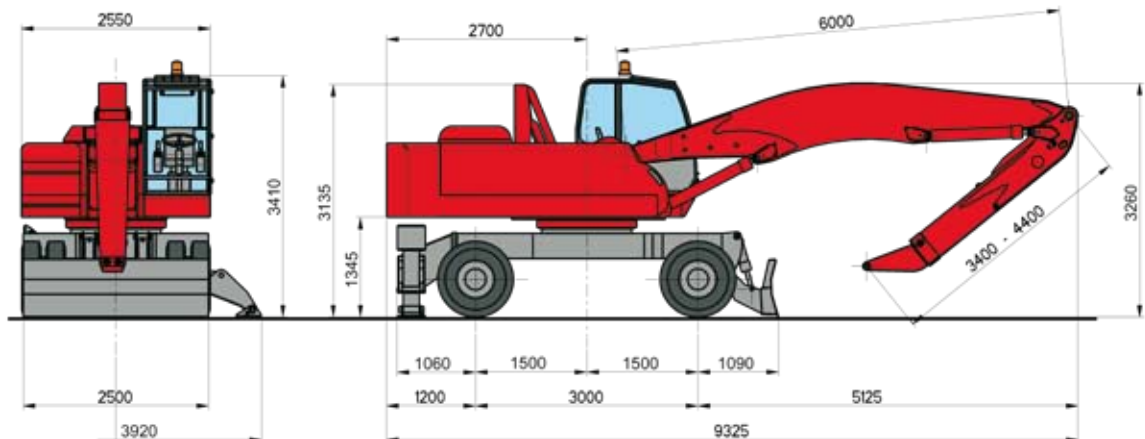

OPERATING WEIGHT 29.400 KG

The new 300 series can stand up to any comparison

313 ESC

All technology at operator's service

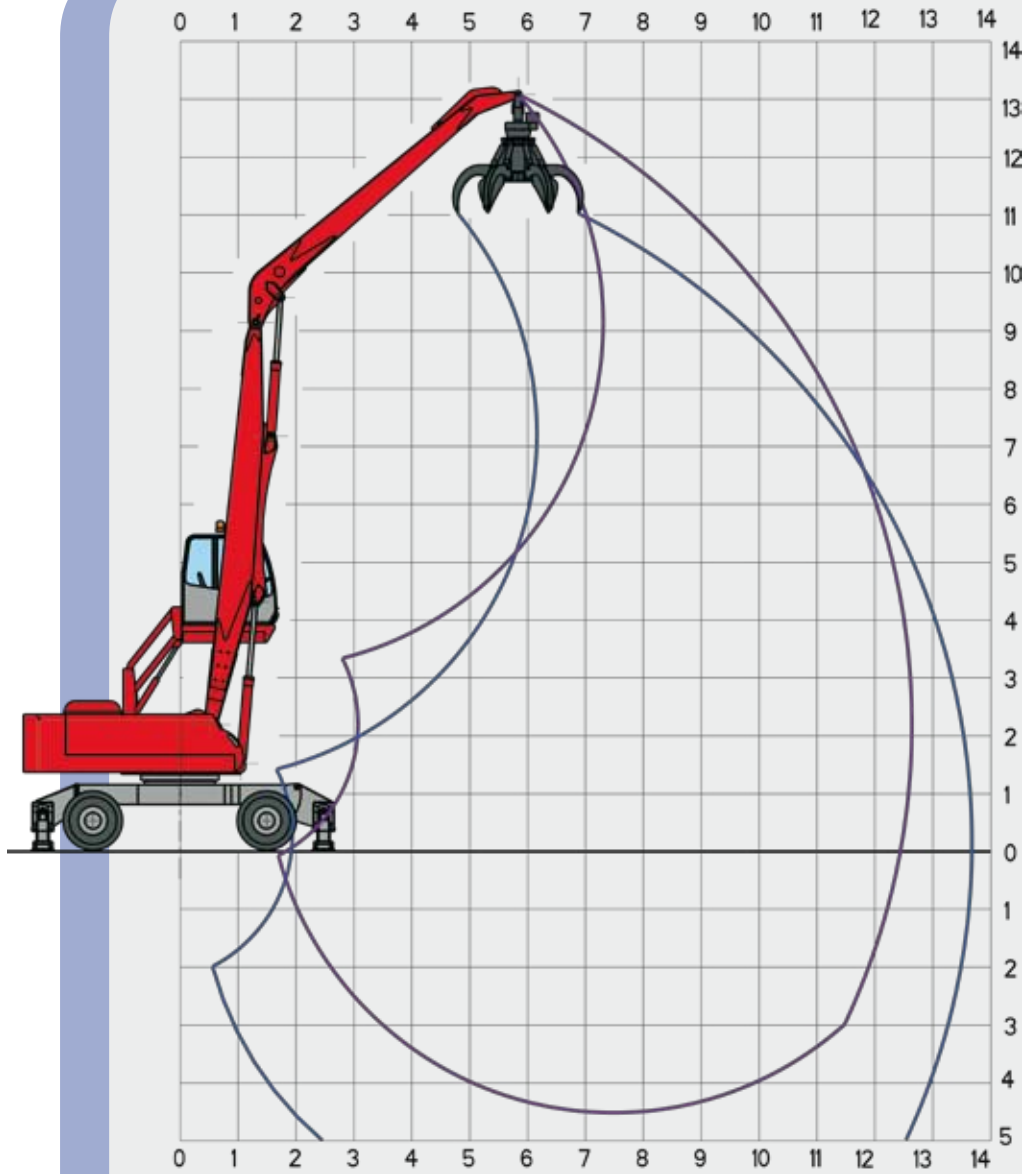

WORKING DIAGRAM FOR SCRAP HANDLING

**Straight boom
7.00 m**

**Industrial
straight stick
6.00 m**

SUGGESTED ORANGE PEEL GRABS

MODEL	FOR SCRAP		FOR WASTE
	SRV 505	SRV 605	SRR 805
OPENING (m)	1,93	2,11	2,20
CAPACITY (l)	500	600	800
WEIGHT WITHOUT ROTATOR (kg)	1050	1490	1200

LIFTING CAPACITIES TONS

LIFTING RANGE (m)

HEIGHT METRES	CONFIGURATION	4.0			6.0			8.0			10.0			12.0			12.6		
		↖	○	⊙	↖	○	⊙	↖	○	⊙	↖	○	⊙	↖	○	⊙	↖	○	⊙
10.0	○○							5,78*	4,61	3,46									
	┆┆							5,78*	5,78*	5,03									
	┆┆							5,78*	5,78*	5,03									
8.0	○○							5,77*	4,59	3,44	4,99	3,09	2,31						
	┆┆							5,77*	5,77*	5,02	5,05*	4,99	3,74						
	┆┆							5,77*	5,77*	5,02	5,05*	5,05*	4,39						
6.0	○○							6,02*	4,40	3,30	4,90	3,00	2,25	3,61	2,11	1,59			
	┆┆							6,02*	6,02*	5,23	5,13*	4,90	3,68	4,38*	3,61	2,71			
	┆┆							6,02*	6,02*	5,23	5,13*	5,13*	4,46	4,38*	4,38*	3,36			
4.0	○○				8,24*	6,35	4,76	6,43*	4,08	3,06	4,73	2,84	2,13	3,54	2,05	1,54			
	┆┆				8,24*	8,24*	7,17	6,43*	6,43*	4,99	5,28*	4,73	3,55	4,37*	3,54	2,66			
	┆┆				8,24*	8,24*	7,17	6,43*	6,43*	5,59	5,28*	5,28*	4,39	4,37*	4,37*	3,31			
2.0	○○	14,67*	9,57	7,18	9,23*	5,54	4,15	6,28	3,73	2,80	4,54	2,66	1,99	3,45	1,96	1,47	3,20	1,80	1,35
	┆┆	14,67*	14,67*	12,76	9,23*	9,23*	7,06	6,82*	6,28	4,71	5,39*	4,54	3,41	4,28*	3,45	2,59	3,93*	3,20	2,40
	┆┆	14,67*	14,67*	12,76	9,23*	9,23*	8,03	6,82*	6,82*	5,87	5,39*	5,39*	4,25	4,28*	4,28*	3,24	3,93*	3,93*	3,01
0	○○	6,37*	6,37*	5,54	8,79	4,94	3,71	5,91	3,39	2,54	4,34	2,47	1,85	3,37	1,88	1,41			
	┆┆	6,37*	6,37*	5,54	9,60*	8,78	6,58	6,89*	5,91	4,43	5,25*	4,33	3,25	3,95*	3,37	2,53			
	┆┆	6,37*	6,37*	5,54	9,60*	9,60*	8,35	6,89*	6,89*	5,58	5,25*	5,25*	4,08	3,95*	3,95*	3,18			
-2.0	○○	6,84*	6,84*	5,82	8,35	4,58	3,43	5,69	3,18	2,39	4,23	2,36	1,77						
	┆┆	6,84*	6,84*	5,95	8,74*	8,35	6,26	6,38*	5,69	4,27	4,70*	4,22	3,17						
	┆┆	6,84*	6,84*	5,95	8,74*	8,74*	7,60	6,38*	6,38*	5,41	4,70*	4,70*	4,00						
-4.0	○○				6,70*	4,53	3,40	4,97*	3,13	2,35									
	┆┆				6,70*	6,70*	5,82	4,97*	4,97*	4,22									
	┆┆				6,70*	6,70*	5,82	4,97*	4,97*	4,32									

- ↖ LIFTING CAPACITIES ON LONGITUDINAL AXIS
- LIFTING CAPACITIES ON 360° WITHOUT SAFETY FACTOR
- ⊙ LIFTING CAPACITIES ON 360° ACCORDING WITH ISO 10567 STANDARD

* = HYDRAULIC LIMIT

LIFTING CAPACITIES ARE ON HOOK WITHOUT GRABS, MACHINE STATIC, LEVEL SOLID GROUND, WITH AXLE LOCKED.

OPERATING WEIGHT WITH 4 OUTRIGGERS, FULL RUBBER TYRES, STRAIGHT BOOM 7.00 m, INDUSTRIAL STICK 6.00 m, SRV 605 ORANGE PEEL GRAB WITH ROTATOR.

DIMENSIONS

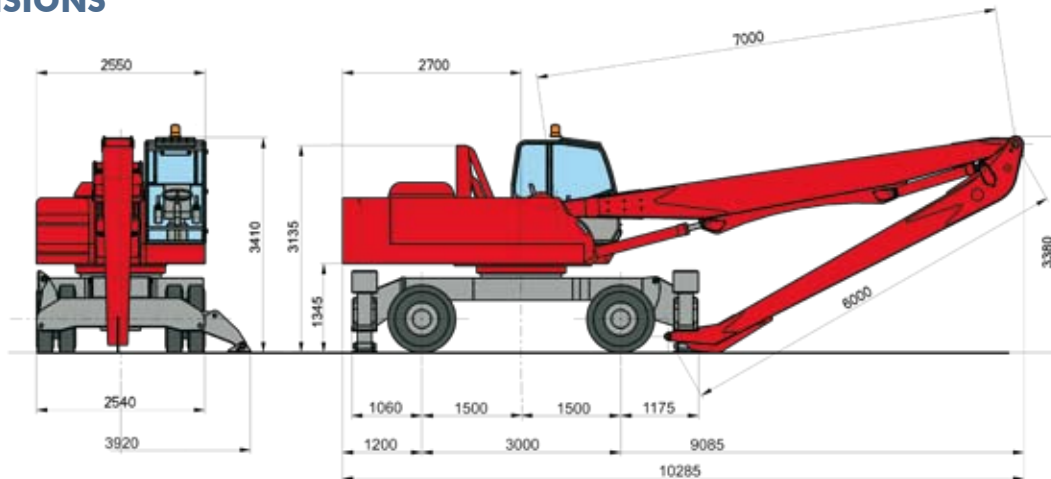

OPERATING WEIGHT 31.000 KG

The new 300 series can stand up to any comparison

313 ESC

All technology at operator's service

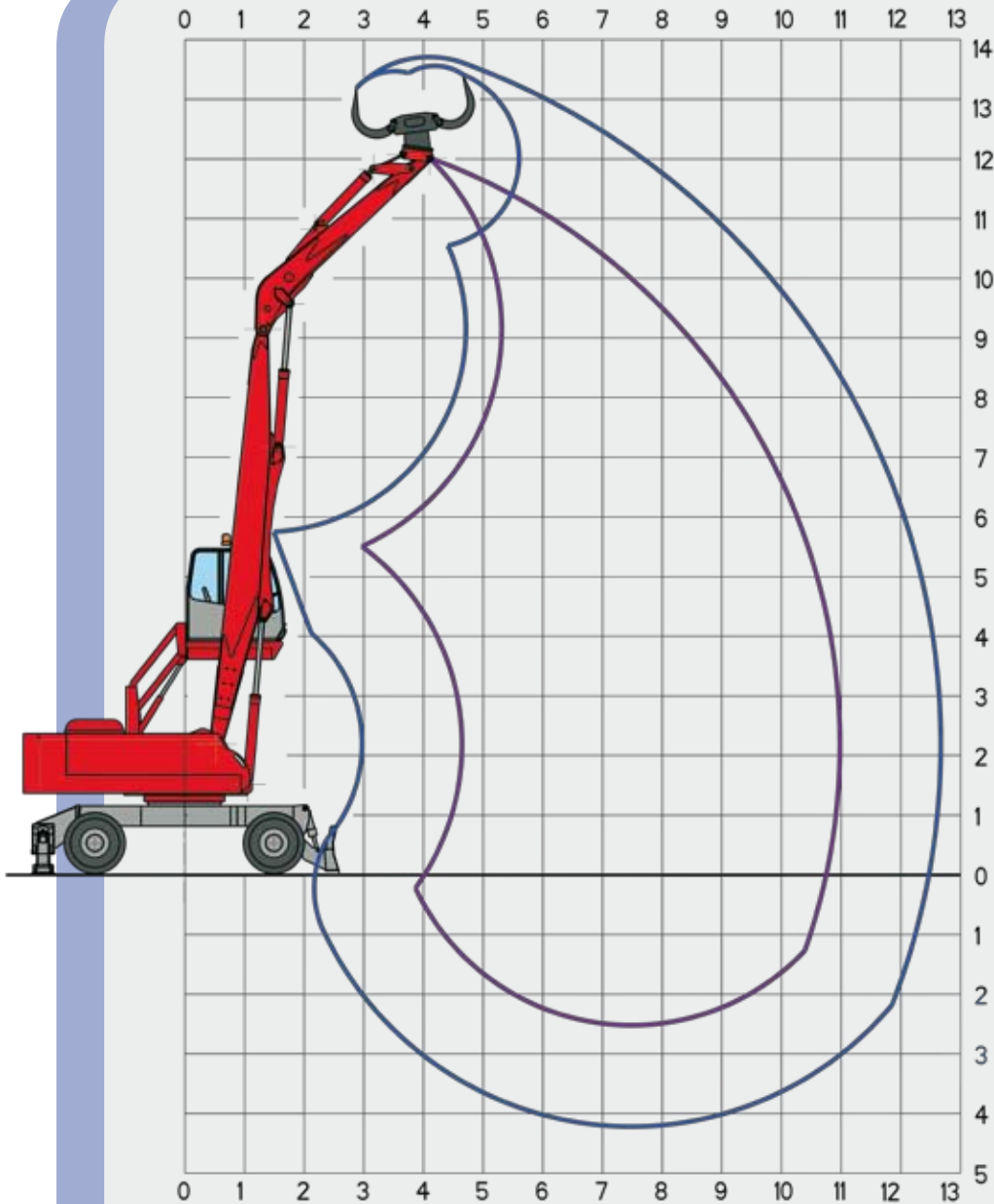

WORKING DIAGRAM FOR WASTE SELECTION

**Straight boom
7.00 m**

**Selector arm
4.00 m**

SELECTOR GRAB

MODEL	SRS 600
OPENING (m)	1,80
CAPACITY (l)	600
WEIGHT WITHOUT ROTATOR (kg)	1050

LIFTING CAPACITIES TONS

LIFTING RANGE (m)

HEIGHT METRES	CONFIGURATION	5.0			7.0			9.0			11.0		
		↖	○	⊙	↖	○	⊙	↖	○	⊙	↖	○	⊙
10.0	○○				6,53*	4,36	3,27						
	┃┃				6,53*	6,53*	5,21						
	┃┃				6,53*	6,53*	5,69						
8.0	○○				6,44*	4,38	3,29						
	┃┃				6,44*	6,44*	5,23						
	┃┃				6,44*	6,44*	5,60						
6.0	○○	8,45*	6,54	4,91	6,70*	4,18	3,14	4,78	2,88	2,16			
	┃┃	8,45*	8,45*	7,36	6,70*	6,70*	5,07	5,57*	4,77	3,58			
	┃┃	8,45*	8,45*	7,36	6,70*	6,70*	5,83	5,57*	5,57*	4,84			
4.0	○○	9,93*	5,96	4,47	6,42	3,86	2,89	4,62	2,73	2,05			
	┃┃	9,93*	9,93*	7,54	7,13*	6,42	4,81	5,65*	4,61	3,46			
	┃┃	9,93*	9,93*	8,64	7,13*	7,13*	6,20	5,65*	5,65*	4,91			
2.0	○○	10,09	5,63	4,22	6,18	3,58	2,69	4,44	2,57	1,92	3,43	1,94	1,46
	┃┃	11,2*	10,09	7,56	7,43*	6,18	4,63	5,59*	4,44	3,33	4,17*	3,43	2,57
	┃┃	11,2*	11,2*	9,75	7,43*	7,43*	6,46	5,59*	5,59*	4,75	4,17*	4,17*	3,58
0.0	○○	8,41*	5,65	4,23	6,08	3,43	2,57	4,35	2,46	1,85			
	┃┃	8,41*	8,41*	7,32	7,04*	6,07	4,56	5,14*	4,34	3,26			
	┃┃	8,41*	8,41*	7,32	7,04*	7,04*	6,13	5,14*	5,14*	4,47			
-2.0	○○				5,6*	3,41	2,56	3,94*	2,45	1,84			
	┃┃				5,6*	5,6*	4,55	3,94*	3,94*	3,25			
	┃┃				5,6*	5,6*	4,88	3,94*	3,94*	3,43			

- ↖ LIFTING CAPACITIES ON LONGITUDINAL AXIS
- LIFTING CAPACITIES ON 360° WITHOUT SAFETY FACTOR
- ⊙ LIFTING CAPACITIES ON 360° ACCORDING WITH ISO 10567 STANDARD

* = HYDRAULIC LIMIT

LIFTING CAPACITIES ARE ON HOOK WITHOUT GRABS, MACHINE STATIC, LEVEL SOLID GROUND, WITH AXLE LOCKED.

OPERATING WEIGHT WITH 4 OUTRIGGERS, FULL RUBBER TYRES, STRAIGHT BOOM 6.00 m, SELECTOR ARM 4.00 m, SRS 600 SELECTOR GRAB.

DIMENSIONS

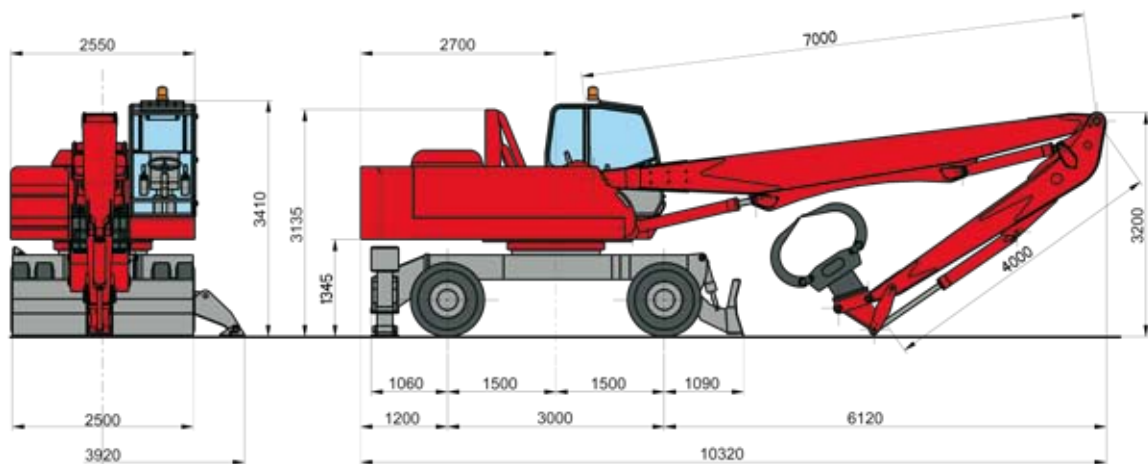

OPERATING WEIGHT 30.800 KG

TECHNICAL DATA

DIESEL ENGINE	<p>TCD 2012 L6 2V – Emission controlled CE 97/68/CE - Step 3 - TIER 3 with electronically controlled injection - 6 cylinders in-line - turbocharged with intercooler air/air - common rail - direct injection - water cooled - electric starting system 24 V - displacement 7146 cm³</p> <p>Power: 149 kW (203 HP) @ 2000 rpm Max torque: 880 Nm @ 1600 rpm Tank capacity: 310 l</p>																				
HYDRAULIC SYSTEM	<p>Open circuit LOAD SENSING + ELECTRONIC SYNCRON CONTROL –Variable displacement axial piston pumps with oil flow adjustment according to the load requirements and with electronic engine speed sensing regulation.</p> <table style="width: 100%; border: none;"> <tr> <td style="width: 33%;">Max. flow:</td> <td style="width: 33%;">420 l/min</td> <td style="width: 33%;">Max. hydr. pressure:</td> <td style="width: 33%;">330 bar</td> </tr> <tr> <td>Hydraulic tank capacity:</td> <td>400 l</td> <td>Hydraulic circuit capacity:</td> <td>480 l</td> </tr> <tr> <td>Gear pump for joystick</td> <td></td> <td>Max. flow:</td> <td>22 l/min</td> </tr> <tr> <td>Gear pump for brakes and steering</td> <td></td> <td>Max. flow:</td> <td>44 l/min</td> </tr> <tr> <td>Gear pump for auxiliary</td> <td></td> <td>Max. flow:</td> <td>44 l/min</td> </tr> </table> <p style="text-align: right;">Max pressure: 30 bar Max pressure: 145 bar Max pressure: 120 bar</p> <p>Hydraulic oil cooling by means aluminium large mesh heat exchange combined with engine radiator. LOAD SENSING system distributor block with simultaneous movements independent of the load and without interaction with synchronised control of all functions.</p>	Max. flow:	420 l/min	Max. hydr. pressure:	330 bar	Hydraulic tank capacity:	400 l	Hydraulic circuit capacity:	480 l	Gear pump for joystick		Max. flow:	22 l/min	Gear pump for brakes and steering		Max. flow:	44 l/min	Gear pump for auxiliary		Max. flow:	44 l/min
Max. flow:	420 l/min	Max. hydr. pressure:	330 bar																		
Hydraulic tank capacity:	400 l	Hydraulic circuit capacity:	480 l																		
Gear pump for joystick		Max. flow:	22 l/min																		
Gear pump for brakes and steering		Max. flow:	44 l/min																		
Gear pump for auxiliary		Max. flow:	44 l/min																		
TRAVEL	<p>Hydrostatic with 4 wheel drive by means of a variable displacement hydraulic axial piston motor mounted on a two speed gearbox hydraulically operated from the cab coupled to the rear axle Travel controlled by two separate pedals (one for each travelling direction).</p> <p>Travel speed (in both directions) Working speed: from 0 to 6 Km/h Travel speed: from 0 to 18 Km/h</p> <p>Differential axles 2,50 m wide with planetary reduction gears on the hubs. Braking valve integrated on the hydraulic motor.</p>																				
STEERING	<p>Hydraulic steering system powered by an independent pump. The floating steering axle can be hydraulically locked from the cabin in any position.</p>																				
BREAKES	<p>SERVICE BRAKES: disk brake on the driveshaft. PARKING AND EMERGENCY BRAKES: hydraulically released disk-type brake mounted on driveshaft.</p>																				
TYRES	<p>n° 8 full rubber tyres “SUPERELASTIC” front and rear twinned 10.00 x 20 n° 4 rubber spacer rings between tyres. n° 8 front and rear twinned “WIDE WALL” tyres 10.00 x 20 - 16 PR</p>																				
SLEWING	<p>Unlimited rotation in both directions by means of an axial piston hydraulic motor with integrated control valve, splined to a double stage reduction gear with oil bath gears. - Anti-shock valves protect the system. High high diameter double row ball bearing ring with internal teeth. Automatic greasing system</p> <p>Max rotation speed: 8 rpm Overall dimensions of rotating turret: 2.70 mt</p>																				
OPERATOR’S CAB	<p>Hydraulically operated raising driver’s cab mounted on a parallelogram linkage (vertical raising on request) installed on silent block with large windows of tinted heat resistant safety glass; front sliding window, and lateral opening window. Winter heating and summer ventilation installed as standard. Air conditioning. Radio preset. Double windscreen wiper with washer.</p> <p>“GRAN COMFORT” operator’s seat with shock absorbing suspension, headrest, lumbar support, belt winder, electric seat heating device and armrests adjustable height and angle. Many possibilities of adjustment according to operator’s weight and size with joysticks incorporated in its arms. AUTO-IDLE electronic accelerator with two automatic preselected rpm.</p> <p>The instrumentation includes: Engine speed indicator, fuel level, water thermometer. Display shows: hour counter, hydraulic oil temperature, Volt, oil engine pressure, fuel consumption, engine diagnostics, and maintenance program. Warning lights showing: air cleaner and oil filter clogging, park brake, low fuel, brakes failure, lights, hydraulic oil low level.</p>																				
HYDRAULIC CONTROLS	<p>N° 2 hydraulically controlled joysticks to carry out four operations each with electric pushbuttons incorporated Electro switch for grab rotator and for dipper telescopic extension (if installed). Electro switch for outriggers and/or front blade. Electro switch for magnet (if installed) Electro hydraulic devices for controlling gear box, parking brakes, hydraulic raising of the cab, front axle oscillation lock.</p>																				
BOOMS	<p>For dimensions see each model</p>																				
SOUND LEVELS	<p>SOUND LEVELS (EEC Directive 2000/14/CE) Inside cab LpA 79 dB (A)</p>																				
ELECTROMAGNETIC COMPATIBILITY	<p>In accordance with EEC Directive 89/336</p>																				
OVERLOAD WARNING DEVICE	<p>Dir. 98/37/CE In accordance with EEC DIRECTIVES 98/37 this device provides to check the crane stability while loading in accordance with loads and distances (as standard) Optical warning advise danger and conditions locking movement when the stability limits are reached. Visualising of the lifting charge and the liftable charge limit, in each position.</p>																				

Solmec reserves the right to modify specifications without prior notice.



SOLMEC 50 YEARS MOVING THE MARKET

Solmec Manufactures Rehandling machines on Wheels, Tracked and on Pedestal. Solmec are the market leader in rehandling in the Italian market and have gained an important position throughout Europe. Versatility, reliability and Stability are the strength points that have made Solmec a major manufacturer in the material handling business. The Solmec machines are designed to work in Scrap Metal industry, Timber Yards and Sawmills, Waste Recycling Depots, Car Dismantlers, Tanneries, Harbours and Railway companies. Solmec is the machine for rehandling material.

SOLMEC QUALITY

Solmec handling machines are made of first class components and materials, and obtained with a continuous updating of working process, and following the most rigid European laws in the matter of safety on work.

MODELS

In order to completely satisfy customers requests, Solmec has developed a range made of more than 15 models: a large and various offer for any request.

series 100LS (108LS)

series 200ESC (208ESC – 210ESC – 212ESC)

series 300ESC (311ESC - 313ESC)

series 400ESC (411ESC – 413ESC – 416ESC)



100 LS
200 ESC
300 ESC
400 ESC
500 ESC

The logo for Solmec, featuring the word "Solmec" in a stylized, italicized red font with a white outline. The letter "S" is particularly large and bold, and the "o" is small and tight. The "l" is thin and vertical, and the "m" and "e" are also stylized. The "c" is a simple curve. The logo is set against a dark blue background with a lighter blue, rounded rectangular shape behind it.

Viale delle industrie, 9
45100 ROVIGO - ITALY
phone +39 0425 474833 r.a.
fax +39 0425 475548
www.solmec.it
solmec@solmec.it