



Universal
ViC57

Mini-excavator



YANMAR.

Vi057

Operating weight : 5325 kg

Arm digging force : 2500 kgf

Bucket digging force : 4300 kgf

Yanmar, inventor and leader of the ZTS mini-excavators



- Real Zero Tail Swing machine : neither the counterweight nor the front part of the upper frame exceed the width of the crawlers.
- Possibility to work along a wall. Safety and productivity for the operator.
- Cabin fully compliant to safety norms : ROPS (Roll Over Protective Structure), FOPS 1 (Falling Object Protective Structure) and TOPS (Tip-Over Protective Structure).
- Boom less bent than in earlier versions to make it easier to reach over a truck, thereby improving productivity during unloading operations.
- Cylinders completely protected (rod and cylinder) by highly elastic steel plates to resist any possible shocks.
- Careful routing and protection of the hydraulic pipes on the boom and on the right side of the machine under the step. You can remove the step to access the sockets and change the equipment pipes.
- Layout of the counterweight designed to protect the side panels against any possible shocks. Additional moulded parts at the left and right outer corners of the upper frame, improving shock resistance.
- Integrated working lamp.

- For increased productivity the blade has been put forward by 20 cm. This allows better control of the job and better levelling. The blade lever, formerly cable operated, is hydraulic.
- The "VICTAS®" system (patented by Yanmar) consists in increasing the bearing surface by increasing the track path and using asymmetric crawlers. Main advantages: increased lateral stability, increased lifting capacity, reduced ground damage, reduced track wear and quiet, vibration-free movement.
- New-generation Yanmar engine which exceeds the most stringent emissions standards.
- "VIPPS®" hydraulic circuit (ViO Progressive 3 Pumps System) fitted with a variable flow dual piston pump and a gear pump : higher precision and possibility to combine various working movements (boom, arm, upper frame). The hydraulic circuit is proportional.
- Perfect combination of the Yanmar engine and the hydraulic system for reduced fuel consumption. Standard electric refuelling pump.
- Spacious operating position, ergonomic armrests and pilot system, pneumatic suspension seat, climate control : reduced operator fatigue.
- Easy access to all maintenance points : engine components, filters, pressure plugs, hydraulic pumps...

TECHNICAL SPECIFICATIONS

Universal
ViC57

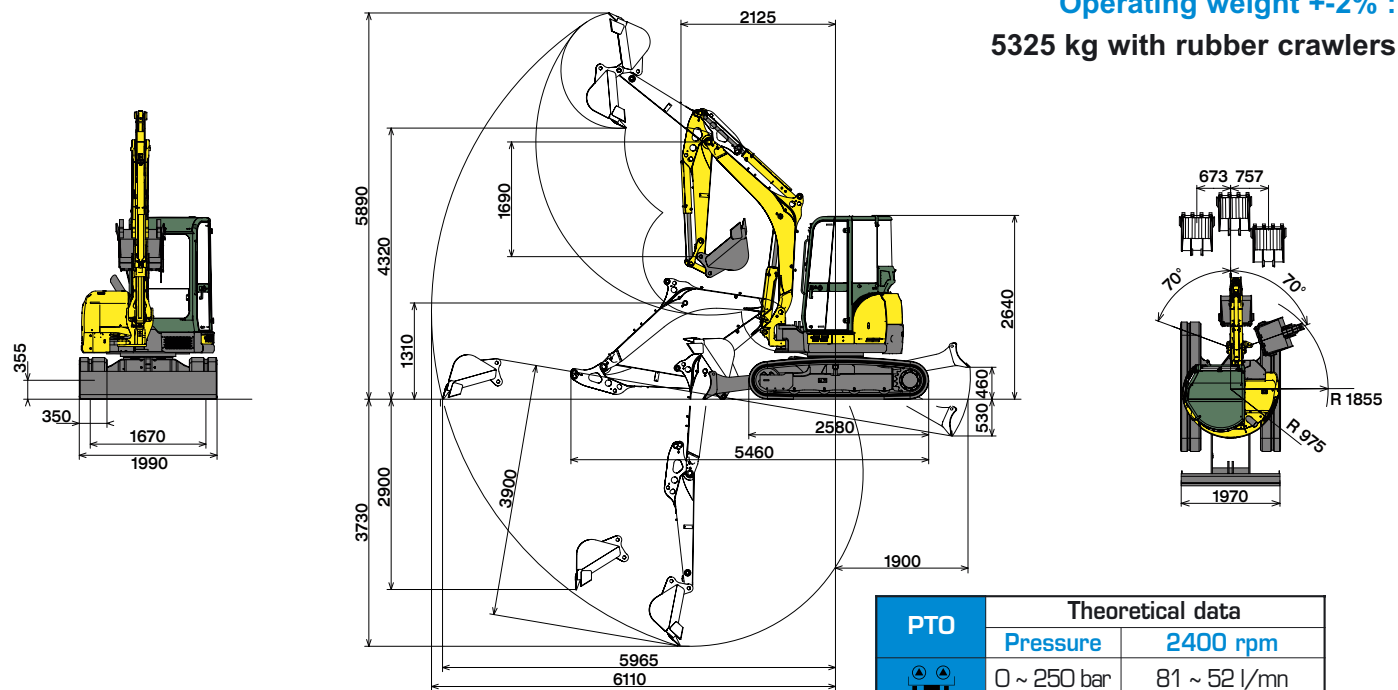

Subject to any technical modifications.
Dimensions given in mm with standard Yanmar bucket.

⚠️ • The output reduces as the pressure increases.

		ViO57
4-cylinder Yanmar engine	Type	4TNV88-BXBVA
	Rated Output (DIN 6270B)	28.8 kw/39.1 HP/2400 rpm
	Displacement	2189 cm ³
	Max. torque	141 N.m./1200 rpm
Hydraulic circuit	System capacity	64 l
	Max. pressure	250 bar
	Variable flow dual piston pump + gear pump	2 x 40.3 l/mn + 1 x 40.3 l/mn
Performances	Travelling speed	2.3/4.4 km/h
	Swing speed	10 rpm
	Digging force (arm)	2500 kgf
	Digging force (bucket)	4300 kgf
	Grade ability	30°
Undercarriage	Ground pressure	0.295/0.300 kg/cm ²
	Shoe width	400 mm
	Ground clearance	355 mm
	Blade (width x height)	1970 x 400 mm
Miscellaneous	Fuel tank	67 l
	Cooling system	6.7 l
	Transport dimensions (L x w x h)	5460 x 1990 x 2640 mm
	Noise level LwA (2000/14/EC & 2005/88/EC)	98 dBA
Optional equipment	Special paint	4th circuit
	Hydraulic quick coupler	Anti-start system
	Standard, ditch cleaning and swivelling buckets	Anti-theft device
	Long arm (+330 mm)	

Machine with cabin, rubber crawlers, bucket of 115 kg (500 mm).

A : Overhang from rotational axis (m).
B : Height of hooking point (m).
C : Safe working load (kg).

📏 Tipping load, rating over front

📏 Tipping load, rating over side 90°

Blade on ground								
A	Maxi		4.0 m		3.0 m		2.5 m	
B	📏	📏	📏	📏	📏	📏	📏	📏
4.0	750	*860	*860	*860	-	-	-	-
3.0	570	*910	*870	*870	-	-	-	-
2.0	490	*940	810	*1090	*1430	*1430	*1850	*1850
1.0	460	*970	780	*1320	1250	*1970	1610	*2650
0	480	*990	750	*1450	1190	*2190	1540	*2710
-1.0	570	*1030	730	*1380	1150	*2050	1560	*2580
-2.0	730	*960	-	-	-	-	1620	*1930

Blade above ground								
A	Maxi		4.0 m		3.0 m		2.5 m	
B	📏	📏	📏	📏	📏	📏	📏	📏
4.0	730	*860	*860	*860	-	-	-	-
3.0	560	580	*870	*850	-	-	-	-
2.0	480	510	800	830	*1430	*1430	*1850	*1850
1.0	450	480	760	800	1220	1280	1600	1750
0	470	510	740	780	1170	1230	1520	1650
-1.0	540	580	700	750	1140	1190	1540	1680
-2.0	720	790	-	-	-	-	1600	1700

The data contained in these tables represent the lifting capacity in accordance with ISO standard 10567.
They correspond to 75 % of the maximum static tipping load or 87 % of the hydraulic lifting power.
Data marked * are the hydraulic limits of the lifting power.



AMMANN-YANMAR SAS

25, rue de la Tambourine - F-52100 SAINT DIZIER

sales@ammann-yanmar.fr

www.ammann-yanmar.com



Versus Studio - Printed in France - Materials and specifications are subject to change from the manufacturer without notice. Please contact your local Ammann-Yanmar dealer for further information.