



Doosan Infracore
Construction Equipment

DX420LC

Engine power: 218 kW / 293 Hp at 1.800 rpm

Operational weight: 40.900 ~ 42.400 kg

Bucket capacity (SAE): 1,44 ~ 2,16 m³



DOOSAN DX420LC hydraulic excavator:

A new



Look at these innovations !

Performance	4
Handling	6
Comfort	7
Reliability	8
Maintenance	10
Technical Specifications	12



The key phrase used during the development of the DX420LC was “giving optimum value to the end user”. This translates, in concrete terms, into:

model with novel features

- **Increased production and improved fuel economy** thanks to electronic optimization of the hydraulic system and the new generation DOOSAN engine (stage IIIa).
- **Improved ergonomics**, increased comfort and excellent all round visibility ensuring a safe and pleasant working environment.
- **Improved reliability** through the use of high performance materials combined with new methods of structural stress analysis have lead to increased component life expectancy, thus reducing running costs.
- **Reduced maintenance** increases the availability of the excavator and reduces running costs.



Performance

The performance of the DX420LC has a direct effect on its productivity. Its new “Common Rail” engine and new e-EPOS controlled hydraulic system have combined to create an unbeatable hydraulic excavator, with a cost/performance ratio that makes the DX420LC even more appealing.



“Common Rail” DOOSAN DV11 engine

At the heart of the hydraulic excavator is the new “Common Rail” Doosan DV11 engine. It is combined with the new e-EPOS electronic control system, for optimum power and fuel saving.

The new engine produces 293 hp (218 kW/297 PS) at only 1.800 rpm, and more torque, due to its careful design combined with the use of common rail injection and 4 valves per cylinder. These features help optimize combustion and minimize pollution through reduced Nox & particulate emissions.

Increased torque allows efficient use of the power of the hydraulic system.

- Faster working cycles increase productivity.
- Increased torque means the excavator is able to move more easily.
- Energy efficiency reduces fuel consumption.

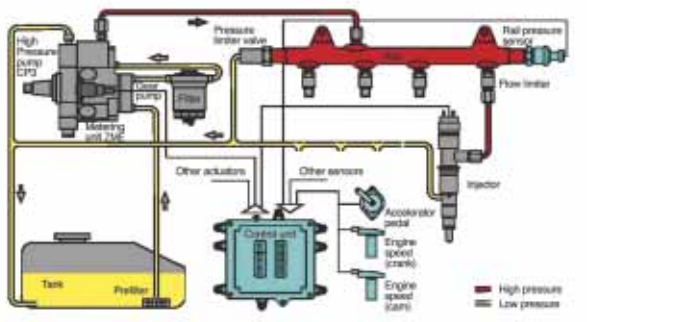

Hydraulic pumps

The main pumps have a capacity of 2 x 315 l / min reducing cycle time while a high capacity gear pump improves pilot line efficiency.



Excavator control

New e-EPOS system (Electronic Power Optimizing System)

The brains of the hydraulic excavator, the e-EPOS, have been improved and now can electronically link to the engines ECU (Electronic Control Unit), through a CAN (Controller Area Network) communication link, enabling a continuous exchange of information between the engine and the hydraulic system. These units are now perfectly synchronised.

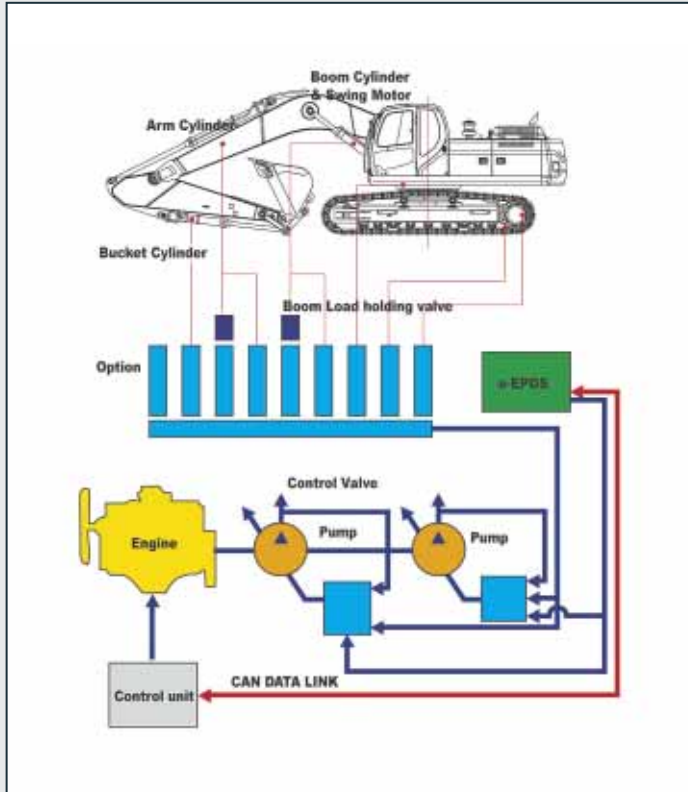

The advantages of the new e-EPOS impacts at several levels.

Ease of operation and user-friendliness:

- The availability of a power mode and a normal operating mode guarantee maximum efficiency under all conditions.
- Electronic control of fuel consumption optimizes efficiency.
- The automatic deceleration mode enables fuel saving.
- Regulation and precise control of the flow rate required by the equipment are available as standard.
- A self-diagnosis function enables technical problems to be resolved quickly and efficiently.
- An operational memory provides a graphic display of the status of the machine.
- Maintenance and oil change intervals can be displayed.

DOOSAN Infracore is aware of the importance of protecting the environment.

Ecology was uppermost in the minds of the research workers right from the start of the design of the new machines. The new challenge for the engineers is to combine the protection of nature with equipment performance and to this end DOOSAN has been investing heavily.

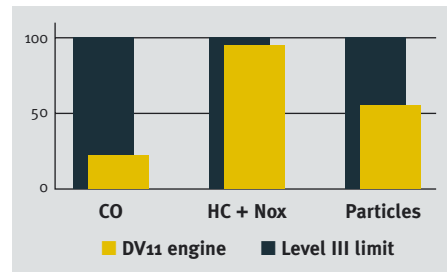

The new DOOSAN engine respects and protects the environment, limiting all types of toxic emissions.



Swing drive

Shocks during rotation are minimized, while increased torque is available to ensure rapid cycles.

Handling

The hydraulic excavator's power, durability, ease of servicing and its precise control increase its effectiveness and life expectancy. With the DX420LC, DOOSAN offers an excellent return on investment.



Multi-function colour LCD monitor panel

Warning lights

Operating modes

- Mode selection
- Flow rate control
- Auto deceleration
- Display selection

Control panel

With colour LCD display



Standard screen



Anti-theft function



Filter/oil information

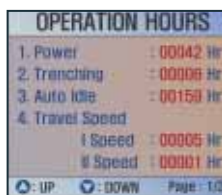

Operation history



Flow rate control

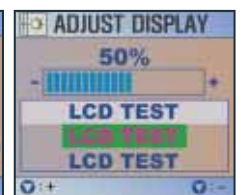

Contrast control

Choice of operating modes

Work mode

- Digging mode: for general excavation, loading, lifting...
- Trenching mode: swing priority for trench work, canal digging, embankments...

Power mode

- Standard: uses 85% engine power for all work (optimum fuel efficiency)
- Power: uses 100% engine power for heavy work



Control lever

Very precise control of the equipment increases versatility, safety and facilitates tricky operations requiring great precision. Levelling operations and the movement of lifted loads in particular are made easier and safer.

The control levers have additional electrical buttons for controlling other additional equipment (for example, grabs, crushers, grippers, etc.).

Comfort

The work rate of the hydraulic excavator is directly linked to the performance of its operator. DOOSAN designed the DX420LC by putting the operator at the centre of the development goals. The result is significant ergonomic value that improves the efficiency and safety of the operator.

More space, better visibility, air conditioning, a very comfortable seat... These are all elements that ensure that the operator can work for hours and hours in excellent conditions.



Control panel

Correct positioning with clear controls makes the operator's task easier.

The high performance air conditioning provides an air flow which is adjusted and electronically controlled for the conditions. Five operating modes enable even the most demanding operator to be satisfied.



Visibility has been improved in all directions and the size of the cab has been increased.



Appropriate storage spaces show the attention given to the operator.



Comfortable fully adjustable seat



Independently adjustable control module height

Reliability

The reliability of an item of plant contributes to its overall lifetime operating costs. DOOSAN uses computer-assisted design techniques, highly durable materials and structures then test these under extreme conditions.

Durability of materials and longevity of structures are our first priorities.

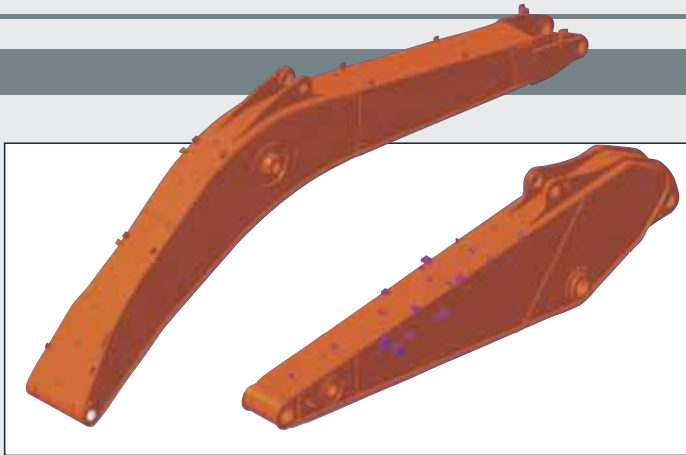

Strengthened boom

The shape of the boom has been optimized by finite elements design, allowing the loads to be better distributed throughout the structure. This combined with increased material thickness means improved durability and reliability by limiting element fatigue.

Arm assembly

In the arm assembly greater strength has been gained by using cast elements and reinforcement around the bosses to give it an increased lifetime.

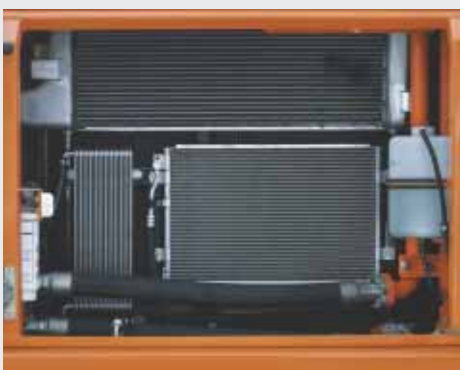

Radiator and oil cooler

The advanced aluminium radiator and oil cooler help demonstrate the best cooling efficiency and have also drastically improved the pressure resistance, vibration resistance and thermal strength.



X-chassis

The X-chassis frame section has been designed using finite element and 3-dimensional computer simulation, to ensure greater durability and optimum structural integrity. The swing gear is solid and stable.

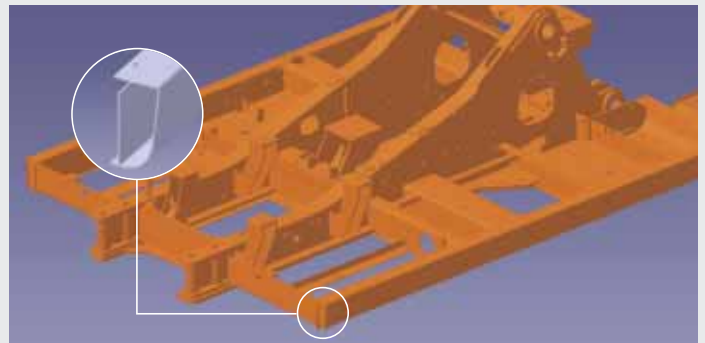

D-type frame

The D-type frame and chassis frame add strength and minimize distortion due to shocks.



Bushing

A highly lubricated metal is used for the boom pivot in order to increase the lifetime and extend the greasing intervals to 250 hours. A rolled bushing with very fine grooves has been added to the arm to bucket pivot, so that greasing is only required every 50 hours.



Ultra hard wear-resistant discs

New materials have been used in order to increase the wear resistance and to increase the service intervals. The longevity is greatly increased by the addition of wear plates on the inside and the outside of the bucket lugs.

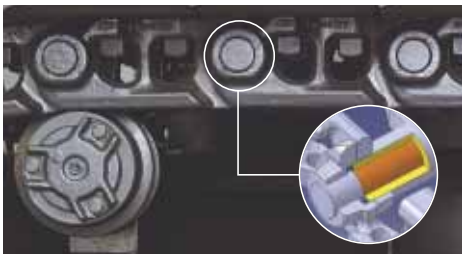

Tracks

The chain is composed of self-lubricating sealed links isolated from all external contamination. The tracks are locked by mechanically bolted pins.



Polymer shim

A polymer shim is added to the bucket pivot to maintain precise control over the equipment.



Pump coupling

A polymer material is used to produce the coupling between the pump and engine. This material has a long life and reduces noise and vibration levels.

Maintenance

Short maintenance operations at long intervals increase the availability of the equipment on site. DOOSAN has developed the DX420LC with a view to high profitability for the user.

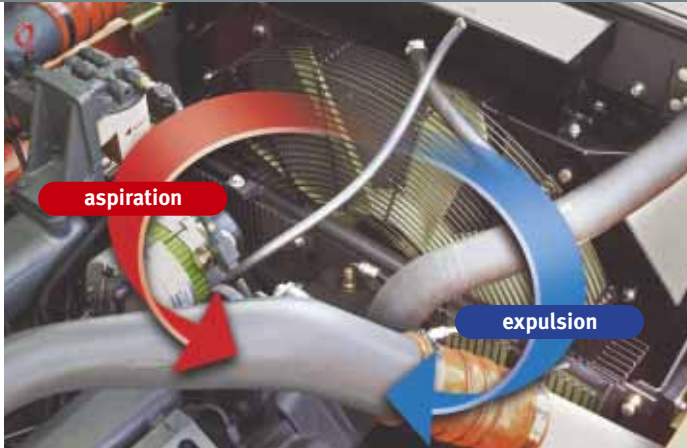

Maintenance of optimum cooling status

During operation, forward rotation maintains optimum cooling, while a conveniently located switch allows the operator to reverse the rotation of the fan to help remove dust and foreign substances from the cooler, contributing to the maintenance of optimum cooling at all times.



Easy maintenance

Access to the various radiators is very easy, making cleaning easier. Access to the various parts of the engine is from the top and via side panels.



Hydraulic oil return filter

The protection of the hydraulic system is made more effective by the use of glass fibre filter technology in the main oil return filter. This means that with more than 99,5% of foreign particles filtered out, the oil change interval is increased.



Air cleaner

The large capacity forced air cleaner removes over 99% of airborne particles, reducing the risk of engine contamination and making the cleaning and cartridge change intervals greater.



Fuel filter

High efficiency fuel filtration is attained by the use of multiple filters, including a fuel pre-filter fitted with a water separator that removes most moisture from the fuel.



Engine oil filter

The engine oil filter offers a high level of filtration allowing the oil change interval to be increased to 500 hours. It is easy to access and is positioned to avoid contaminating the surrounding environment.



Centralized grease inlets for easy maintenance

The arm grease inlets are grouped for easy access.

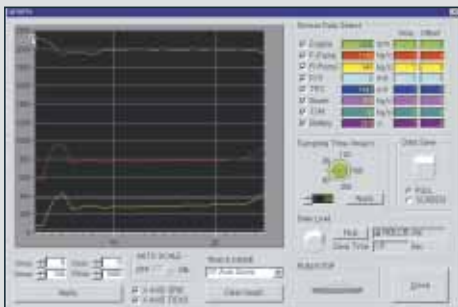

PC monitoring

A PC monitoring function enables connection to the e-EPOS system, allowing various parameters to be checked during maintenance, such as pump pressures, engine rotation speed, etc, and these can be stored and printed for subsequent analysis.

Technical specifications

DX420LC

* Engine

• Model

DOOSAN DV11
 “Common Rail” engine with direct fuel injection and electronic control, 4 valves per cylinder, vertical injectors, water cooled, turbo charged with air to air intercooler.
 The emission levels are well below the values required for Phase III.

• Number of cylinders

6

• Nominal flywheel power

218 kW (297 Ps) at 1.800 rpm (DIN 6271 net)
 218 kW (293 Hp) at 1.800 rpm (SAE J1349 net)

• Max torque

140 kgf.m (1.373 Nm) at 1.300 rpm

• Piston displacement

10.964 cc

• Bore & stroke

128 mm x 142 mm

• Starter

24 V / 7 kW

• Batteries

2 x 12 V / 150 Ah

• Air cleaner

Double element and pre-filtered Turbo with auto dust evacuation.

* Hydraulic system

The heart of the system is the e-EPOS (Electronic Power Optimizing System). It allows the efficiency of the system to be optimized for all working conditions and minimizes fuel consumption.

The new e-EPOS is connected to the engine electronic control via a data transfer link to harmonize the operation of the engine and hydraulics.

- The hydraulic system enables independent or combined operations.
- Two travel speeds offer either increased torque or high speed tracking.
- Cross-sensing pump system for fuel savings.
- Auto deceleration system.
- Two operating modes, two power modes.
- Button control of flow in auxiliary equipment circuits.
- Computer-aided pump power control.

• Main pumps

2 variable displacement axial piston pumps
 Max flow: 2 x 315 l/min

• Pilot pump

Gear pump – max flow: 22 l/min

• Main relief valves

Boom/arm/bucket:
 Normal mode: 320 kg/cm² (314 bar)
 Power mode: 350 kg/cm² (343 bar)
 Travel: 320 kg/cm² (314 bar)
 Rotation: 270 kg/cm² (265 bar)

* Weight

Boom 6.700 mm • Arm 3.250 mm • Bucket 1,90 m³ (SAE) • Shoes 600 mm.

	Shoe width (mm)	Operating weight (kg)	Ground pressure (kg/cm ²)
Triple grouser	600 (std)	40.900	0,74
	750	41.600	0,61
	800	41.900	0,57
	900	42.400	0,50
Double grouser	600 (opt)	41.700	0,76

* Hydraulic cylinders

The piston rods and cylinder bodies are made of high-strength steel. A shock absorbing mechanism is fitted in all cylinders to ensure shock-free operation and extend piston life.

Cylinders	Quantity	Bore x Rod diameter x stroke
Boom	2	165 x 115 x 1.460 mm
Arm	1	180 x 120 x 1.820 mm
Bucket	1	160 x 110 x 1.320 mm

* Undercarriage

Chassis are of very robust construction, all welded structures are designed to limit stresses.

High-quality material used for durability.

Lateral chassis welded and rigidly attached to the undercarriage.

Track rollers lubricated for life, idlers and sprockets fitted with floating seals.

Tracks shoes made of induction-hardened alloy with triple grousers.

Heat-treated connecting pins.

Hydraulic track adjuster with shock-absorbing tension mechanism.

• Number of rollers and track shoes per side

Upper rollers: 2 (standard shoes)

Lower rollers: 9

Shoes: 50

Total length of track: 5.200 mm

* Environment

Noise levels comply with environmental regulations (dynamic values).

• Sound level guarantee

104 dB(A) (2000/14/EC)

• Cab sound level

73 dB(A) (ISO 6396)

* Swing mechanism

- An axial piston motor with two-stage planetary reduction gear is used for the swing.
- Increased swing torque reduces swing time.
- Internal induction-hardened gear.
- Internal gear and pinion immersed in lubricant bath.
- The swing brake for parking is activated by spring and released hydraulically.

Swing speed: 0 to 9,2 rpm

* Drive

Each track is driven by an independent axial piston motor through a planetary reduction gearbox.

Two levers with control pedals guarantee smooth travel with counter-rotation on demand.

• Travel speed (fast/slow)

5,3 / 3,1 km/h

• Maximum traction force

17.200 / 32.500 kgf

• Maximum grade

35° / 70 %

* Refill capacities

• Fuel tank

550 l

• Cooling system (Radiator capacity)

40 l

• Engine oil

44 l

• Swing drive

6 l

• Final drive

11 l (each)

• Hydraulic system

420 l

* Buckets

Capacity (m³)	Width (mm)		Weight (kg)	Recommended Arm (mm)			
	Without side cutters	With side cutters		2.600	3.250	3.950	3.250 HD
1,44	1.192	1.273	1.470	A	A	A	–
1,68	1.348	1.429	1.580	A	A	B	–
1,90	1.466	1.547	1.710	A	B	B	–
2,16	1.664	1.745	1.830	B	B	C	–
1,51	1.384	1.498	1.720	–	–	–	A

A. Suitable for materials with a density less than or equal to 2,000 kg/m³

B. Suitable for materials with a density less than or equal to 1,600 kg/m³

C. Suitable for materials with a density less than or equal to 1,100 kg/m³

Dimensions and Working ranges

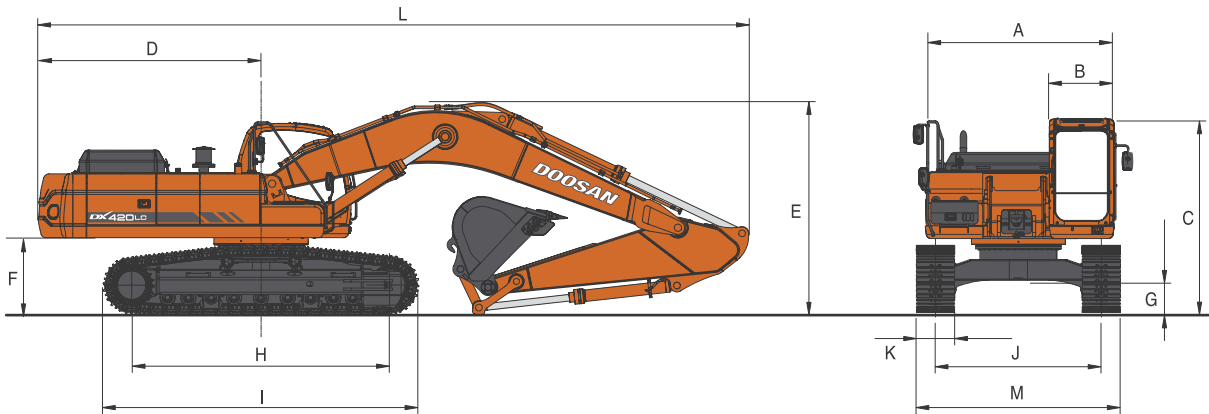

Dimensions – Boom: 6.700 mm - Arm: 3.250 mm - Shoe: 600 mm - Std.

* Dimensions

A	Overall width of upper structure	2.990 mm
B	Overall width of cabin	1.010 mm
C	Overall height of cabin	3.154 mm
D	Tail swing radius	3.660 mm
E	Overall height	2,6 m 3,25 m (Std/HD) 3,95 m
F	Clearance under counterweight (Std/HD)	1.265/1.275 mm
G	Ground clearance (Std/HD)	540/555 mm
H	Tumbler distance	4.250 mm
I	Track length (Std/HD)	5.200/5.205 mm
J	Track gauge	2.750 mm
K	Track shoe width	600 mm
L	Overall length	2,6 m 3,25 m (Std/HD) 3,95 m
M	Overall width	3.350 mm

* Digging forces (ISO)

Arm	2,6 m	3,25 m	3,95 m
Bucket digging force*	27.000 kgf 265 kN	27.000 kgf 265 kN	27.000 kgf 265 kN
Arm digging force*	24.400 kgf 293 kN	19.700 kgf 193 kN	16.900 kgf 166 kN

* Max. force

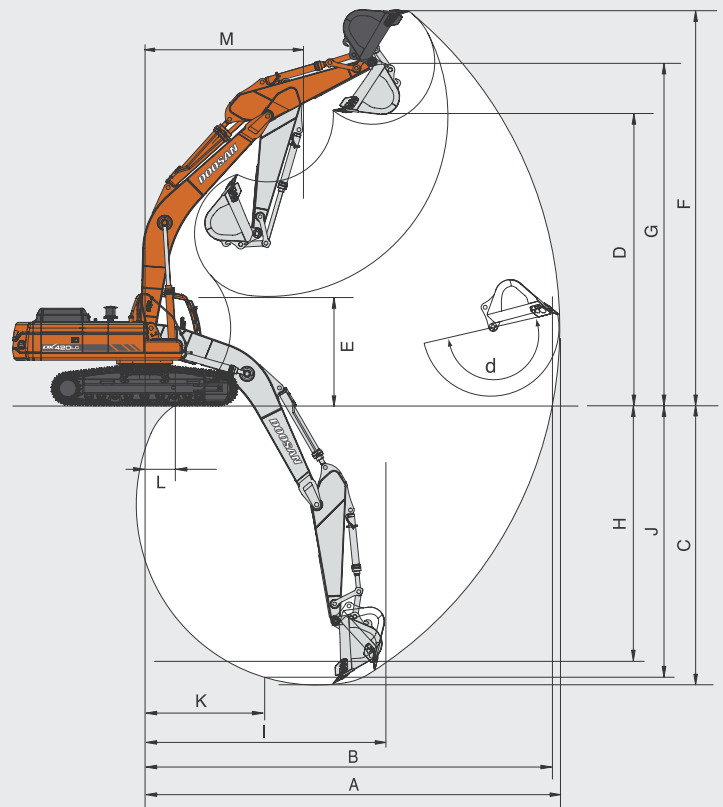

* Working range

Boom length	6.700 mm			
	2.600 mm ³	3.250 mm	3.950 mm	3.250 mm HD
Arm length				
Type of bucket (PCSA)	2,16 m ³	1,90 m ³	1,44 m ³	1,51 m ³
A. Max. digging reach	mm	10.880	11.495	12.170
B. Max. digging reach at ground level	mm	10.660	11.290	11.980
C. Max. digging depth	mm	7.080	7.730	8.430
D. Max. dumping height	mm	7.460	7.795	8.200
E. Min. dumping height	mm	3.700	3.050	2.340
F. Max. digging height	mm	10.560	10.920	11.350
G. Max. bucket pin height	mm	9.190	9.520	9.930
H. Max. vertical wall height	mm	3.650	4.350	5.140
I. Max. vertical radius	mm	9.170	9.440	9.700
J. Max. digging depth (8° level)	mm	6.880	7.570	8.290
K. Min. radius 8° line	mm	3.460	3.490	3.530
L. Min. digging reach	mm	2.390	820	-200
M. Max. swing radius	mm	4.380	4.380	4.440
d. Bucket angle (deg)	°	183	183	183



Lifting capacity

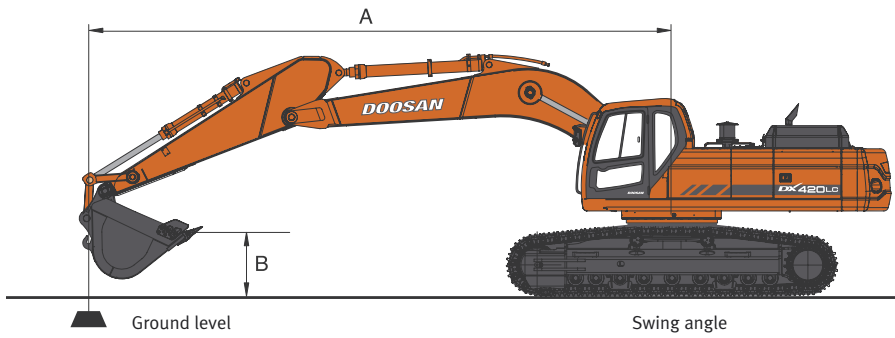

DX420LC

Standard configuration

Standard — Boom: 6.700 mm - Arm: 3.250 mm - Bucket: SAE 1,9 m³ (CECE 1,7 m³), Weight: 1.710 kg - Shoe: 600 mm

Units: 1.000 kg

A (m) \ B (m)	2		3		4		5		6		7		8		9		Max. lift		A(m)	
8																		*7,28	*7,28	7,81
7											*7,69	*7,69	*7,63	7,62				*7,32	6,85	8,48
6											*8,15	*8,15	*7,86	7,52				*7,48	6,10	8,99
5										*9,63	*9,63	*8,83	*8,83	*8,27	7,38	*7,91	6,00	*7,74	5,59	9,36
4			*23,59	*23,59	*16,23	*16,23	*12,85	*12,85	*10,90	*10,90	*9,66	8,97	*8,81	7,21	*8,22	5,89	*7,96	5,24	9,61	
3					*19,89	*19,89	*14,95	14,69	*12,23	11,07	*10,53	8,70	*9,39	7,02	*8,58	5,78	*8,13	5,02	9,76	
2					*17,09	*17,09	*16,75	14,11	*13,44	10,69	*11,36	8,44	*9,24	6,85	*8,94	5,66	7,99	4,91	9,79	
1					*14,73	*14,73	*17,99	13,70	*14,38	10,39	*12,03	8,23	*10,41	6,70	9,06	5,56	8,01	4,90	9,72	
O (ground)			*8,19	*8,19	*15,98	*15,98	*18,60	13,45	*14,97	10,18	*12,49	8,07	*10,73	6,58	8,97	5,48	8,18	4,99	9,55	
-1	*8,94	*8,94	*11,95	*11,95	*18,85	*18,85	*18,67	13,33	*15,17	10,06	*12,68	7,97	10,71	6,51	8,92	5,43	8,54	5,20	9,26	
-2	*12,71	*12,71	*15,91	*15,91	*22,78	19,29	*18,26	13,31	*14,99	10,01	*12,56	7,92	10,68	6,48			9,15	5,37	8,85	
-3	*16,58	*16,58	*20,32	*20,32	*21,39	19,41	*17,38	13,37	*14,38	10,04	*12,05	7,94	*10,13	6,51			*9,58	6,17	8,30	
-4	*20,85	*20,85	*24,17	*24,17	*19,43	*19,43	*15,96	13,50	*13,25	10,14	*11,02	8,03					*9,83	7,16	7,57	
-5	*25,81	*25,81	*20,46	*20,46	*16,70	*16,70	*13,81	13,72	*11,38	10,32							*9,99	8,94	6,61	
-6			*15,34	*15,34	*12,77	*12,77	*10,45	*10,45									*9,80	*9,80	5,28	

HD Version — Boom: 6.700 mm - Arm: 3.250 m - Bucket: SAE 1,51 m³ (CECE 1,31 m³), Weight: 1.720 kg - Shoe: 600 mm

Units: 1.000 kg

A (m) \ B (m)	2		3		4		5		6		7		8		9		Max. lift		A(m)	
8																		*7,34	*7,34	7,80
7											*7,62	*7,62	*7,55	7,53				*7,37	6,78	8,47
6											*8,08	*8,08	*7,77	7,43				*7,52	6,02	8,98
5										*9,57	*9,57	*8,75	*8,75	*8,18	7,28	*7,81	5,91	*7,73	5,51	9,35
4			*22,17	*22,17	*16,29	*16,29	*12,81	*12,81	*10,83	*10,83	*9,56	8,87	*8,70	7,11	*8,11	5,80	*7,86	5,16	9,60	
3					*19,91	*19,91	*14,89	14,57	*12,14	10,96	*10,42	8,60	*9,27	6,93	*8,46	5,68	*8,02	4,94	9,74	
2					*15,86	*15,86	*16,66	13,99	*13,33	10,58	*11,23	8,34	*9,82	6,75	*8,81	5,56	7,97	4,83	9,77	
1					*14,00	*14,00	*17,85	13,59	*14,24	10,28	*11,90	8,13	*10,27	6,60	9,01	5,49	7,99	4,82	9,71	
O (ground)			*7,74	*7,74	*15,51	*15,51	*18,42	13,35	*14,80	10,08	*12,34	7,97	*10,58	6,49	8,93	5,39	8,16	4,92	9,53	
-1	*8,66	*8,66	*11,68	*11,68	*18,57	*18,57	*18,45	13,25	*14,98	9,97	*12,51	7,87	10,67	6,42	8,88	5,35	8,53	5,13	9,24	
-2	*12,58	*12,58	*15,78	*15,78	*22,45	19,24	*18,01	13,23	*14,77	9,93	*12,36	7,84	*10,49	6,39			*9,15	5,51	8,83	
-3	*16,57	*16,57	*20,35	*20,35	*21,03	19,38	*17,09	13,30	*14,13	9,96	*11,82	7,86	*9,90	6,43			*9,41	6,13	8,27	
-4	*21,00	*21,00	*23,63	*23,63	*19,03	*19,03	*15,63	13,45	*12,97	10,07	*10,75	7,96					*9,63	7,14	7,54	
-5	*25,32	*25,32	*19,86	*19,86	*16,25	*16,25	*13,43	*13,43	*11,03	10,27							*9,73	8,97	6,57	
-6					*12,23	*12,23	*9,97	*9,97										*9,44	*9,44	5,23

- The nominal forces are based on the SAE J1097 standard.
- The load point is the hook at the rear of the bucket.
- * = The nominal loads are based on hydraulic capacity.
- The nominal loads do not exceed 87% of the hydraulic capacity or 75% of the capacity of the swing.

: Nominal force
 : Nominal force at the side or 360°

Option — Boom: 6.700 mm - Arm: 2.600 mm - Bucket: SAE 2,16 m³ (CECE 1,92 m³), Weight: 1.830 kg - Shoe: 600 mm

Units: 1.000 kg

A (m)	2		3		4		5		6		7		8		Max. lift		A(m)	
	☐	☐	☐	☐	☐	☐	☐	☐	☐	☐	☐	☐	☐	☐	☐	☐		
8																*8,71	*8,71	6,76
7												*8,73	*8,73			*8,64	8,26	7,53
6										*9,77	*9,77	*9,10	*9,10	*8,70	7,33	*8,67	7,18	8,10
5			*21,68	*21,68	*15,38	*15,38	*12,47	*12,47	*10,78	*10,78	*9,71	9,01	*9,01	7,21	*8,77	6,48	8,51	
4					*19,17	*19,17	*14,46	*14,46	*11,98	11,16	*10,45	8,75	*9,45	7,05	*8,91	6,02	8,79	
3							*16,37	14,18	*13,17	10,76	*11,22	8,50	*9,93	6,88	*9,08	5,74	8,94	
2							*17,79	13,69	*14,17	10,43	*11,90	8,27	*10,37	6,73	9,11	5,60	8,98	
1					*10,85	*10,85	*18,51	13,41	*14,84	10,19	*12,40	8,09	*10,69	6,61	9,14	5,59	8,91	
0 (ground)					*15,63	*15,63	*18,63	13,28	*15,12	10,04	*12,65	7,97	10,73	6,52	9,40	5,73	8,72	
-1			*13,39	*13,39	*21,20	19,25	*18,25	13,25	*15,02	9,98	*12,60	7,91	10,69	6,48	9,92	6,03	8,40	
-2	*16,56	*16,56	*19,74	*19,74	*21,10	19,36	*17,45	13,30	*14,51	9,99	*12,19	7,92			*10,36	6,57	7,94	
-3	*22,09	*22,09	*23,05	*23,05	*19,36	*19,36	*16,17	13,42	*13,53	10,08	*11,30	8,00			*10,63	7,49	7,32	
-4			*20,05	*20,05	*16,96	*16,96	*14,26	13,63	*11,88	10,25					*10,79	9,14	6,48	
-5			*15,75	*15,75	*13,54	*13,54	*11,35	*11,35							*10,63	*10,63	5,32	

Option — Boom: 6.700 mm - Arm: 3.950 m - Bucket: SAE 1,44 m³ (CECE 1,29 m³), Weight: 1.470 kg - Shoe: 600 mm

Units: 1.000 kg

A(m)	2		3		4		5		6		7		8		9		10		Max. lift		A(m)	
	☐	☐	☐	☐	☐	☐	☐	☐	☐	☐	☐	☐	☐	☐	☐	☐	☐	☐	☐	☐		
9																				*5,73	*5,73	7,89
8													*6,75	*6,75						*5,64	*5,64	8,68
7													*6,83	*6,83	*6,67	6,31				*5,65	*5,65	9,29
6													*7,13	*7,13	*7,04	6,25				*5,73	5,37	9,75
5											*7,99	*7,99	*7,60	7,55	*7,32	6,15	*6,36	5,06		*5,89	4,97	10,10
4									*9,83	*9,83	*8,87	*8,87	*8,18	7,36	*7,69	6,02	*7,36	4,98	*6,11	4,69	10,33	
3			*16,80	*16,80	*17,40	*17,40	*13,49	*13,49	*11,25	*11,25	*9,81	8,88	*8,83	7,16	*8,13	5,88	*7,62	4,89	*6,42	4,51	10,46	
2			*7,32	*7,32	*20,68	20,57	*15,54	14,44	*12,60	10,90	*10,74	8,59	*9,47	6,96	*8,56	5,74	7,80	4,80	*6,81	4,41	10,50	
1			*6,96	*6,96	*17,86	*17,86	*17,14	13,92	*13,75	10,54	*11,55	8,34	*10,04	6,78	*8,95	5,62	7,71	4,72	7,20	4,39	10,43	
0 (ground)	*4,85	*4,85	*8,63	*8,63	*16,69	*16,69	*18,16	13,56	*14,57	10,27	*12,18	8,14	*10,49	6,63	9,01	5,51	7,64	4,65	7,32	4,45	10,27	
-1	*7,79	*7,79	*11,06	*11,06	*17,98	*17,98	*18,62	13,35	*15,04	10,09	*12,56	8,00	10,73	6,53	8,93	5,44	7,59	4,61	7,59	4,61	10,01	
-2	*10,70	*10,70	*13,96	*13,96	*20,61	19,15	*18,57	13,26	*15,12	10,00	*12,65	7,91	10,66	6,47	8,89	5,41			8,03	4,88	9,63	
-3	*13,78	*13,78	*17,33	*17,33	*22,59	19,21	*18,04	13,26	*14,81	9,97	*12,41	7,89	*10,54	6,45	8,90	5,42			8,73	5,31	9,12	
-4	*17,19	*17,19	*21,33	*21,33	*21,05	19,36	*17,00	13,34	*14,04	10,02	*11,75	7,93	*9,85	6,50					*9,00	5,99	8,47	
-5	*21,11	*21,11	*23,82	*23,82	*18,84	*18,84	*15,37	13,50	*12,71	10,15	*10,50	8,05							*9,22	7,11	7,62	
-6	*25,77	*25,77	*19,53	*19,53	*15,72	*15,72	*12,87	*12,87	*10,48	10,37									*9,31	9,19	6,51	
-7					*11,10	*11,10														*8,95	*8,95	4,95



Standard and optional equipment

* Standard equipment

• Hydraulic system

- Boom and arm flow regeneration
- Boom and arm safety valves
- Swing anti-rebound valves
- Spare ports (valve)
- One touch power boost
- Hydraulic piping for breaker

• Cab & Interior

- Cab mounted on viscous support
- All weather sound suppressed type cab
- Air conditioning with climat control
- Adjustable suspension seat with adjustable head rest and arm rests
- Sliding front window removable in two parts
- Room light
- Intermittent windshield wiper
- Cigarette lighter and ashtray
- Cup holder
- Hot & cool box
- LCD color monitor
- Fuel control dial
- Remote radio control on console
- Loudspeakers and connections for radio
- 12 V power outlet
- PC interface port for Diagnostics
- Hydraulic control levers with 3 switches
- Sun roof
- Sun visor
- Rainshield

• Safety

- Large handrail and steps
- Punched metal anti-slip plates
- Seatbelt
- Hydraulic safety lock lever
- Safety glass windows
- Hammer for emergency escape
- Side mirrors
- Emergency engine stop (switch)
- Overload warning device

• Undercarriage

- Hydraulic track tension adjuster
- Track guards
- Greased and sealed track links

• Other

- Two-stage air cleaner with one safety element
- Dust screen for radiators
- Engine overheat prevention system
- Engine restart prevention system
- Self-diagnostic system
- Alternator 24V, 50A
- Horn
- Halogen working lights
 - Chassis mounted 2
 - Boom mounted 2
- Double fuel filter
- Fuel tank filling pump

* Optional equipment

Some of these optional equipments may be standard in some markets. Some of these optional equipments cannot be available on some markets. You must check with the local DOOSAN dealer to know about the availability or to release the adaptation following the needs of the application.

• Safety

- Cabin Top/Front guard (ISO 10262, standard FOGS)
- Travel alarm
- Swing alarm
- Rotating beacon

• Cab & Interior

- Heated air suspension seat
- Radio/CD
- Radio/CD/MP3

• Undercarriage

- 750, 800, 900 mm triple grouser shoes
- Complete track link protection
- Double grouser shoes

• Other

- Hydraulic piping for crusher
- Hydraulic piping for quick coupler
- Hydraulic piping for clamshell
- Hydraulic piping for tilting and rotating
- Additional filter for breaker piping
- Lower cabin windshield wiper
- Fuel heater
- Light Pack (4 front & 2 rear cabin lights, telescopic beacon, 80Ah alternator)
- Video system with color LCD and 0 Lux camera
- Upper guard for front glass
- Lower guard for front glass
- Centralize greasing system

DOOSAN Infracore Europe S.A.

1st, rue Achille Degrâce
7080 Frameries, Belgium
Tel : +32-65-61 32 30 • Fax : +32-65-67 73 38

DOOSAN Infracore France SA

Buroplus 2
Parc d'Activités de La Clef St Pierre
Avenue Jean d'Alembert, bâtiment n° 2
78990 Elancourt, France
Tel : +33-1-30 16 21 41 • Fax : +33-1-30 16 21 44

DOOSAN Infracore U.K., Ltd.

Doosan House, Unit 6, 3 Heol-Y-Gamlas, Parc Nantgarw,
Nantgarw, Cardiff CF15 7QU, U.K.
Tel : +44-1443-84-2273 • Fax : +44-1443-84-1933

DOOSAN Infracore Germany GmbH

Heinrich-von-Stephan-Str. 2
D-40764, Langenfeld, Germany
Tel : +49-2173-2035212 • Fax : +49-2173-2035219

Head Office

Doosan Tower 26th FL. 18-12, Euljiro-6Ga,
Jung-Gu, Seoul, Korea 100-730
Tel : +82-2-3389-8114 • Fax : +82-2-3389-8117

www.doosaneurope.com

