



Zettelmeyer ZL 602/602 SL



An Agile Allrounder - Tested under Hard Conditions

- **High-performance, environmentally-friendly diesel engine:** quiet, low emissions, economical fuel consumption.
- **Hydrostatic drive**
with significant advantages:
 - Easy to operate due to automatic drive facility
 - Maintains high drawbar pull even when working hydraulics are engaged
 - Advantageous hydrostatic brakes, wear-free and safe
- **Powerful Z-bar loader-linkage**
with two lifting cylinders:
 - High breakout force and lifting capacity in bucket applications
 - Excellent fork-lift capacity
- Optimum traction, due to **supplementary 100% differential locks** in both axles.
- Standard **hydraulic quick-change coupling:**
Various tried-and-tested attachments for a wide range of applications
- **Purpose designed cab comfort** for extra performance.
Audio-visual warning system for monitoring operating systems
- **Gross Power:**
SAE J1995 42/57 kW/hp
- **Operating Weight:**
4,6 t (10141 lb)
- **Bucket Capacities:**
0,8 - 1,5 m³ (1,0-1,9 yd³)

Zettelmeyer



ENGINE

Engine: in-line 4-cylinder, 4 stroke, direct injection diesel engine with turbocharging, oil/air cooled.

Two-stage air cleaning:

1. Paper filter with indicator in cab
2. Safety filter

Make	KHD			
Type	BF4 L 1011 T			
Gross power @	2200	r/min	(36,7	r/s)
SAE J1995	42	kW	(57	hp)
Net power @	2200	r/min	(36,7	r/s)
SAE J1349	41	kW	(56	hp)
DIN 70020/6271	41	kW	(56	hp)
Max. torque at	1550	r/min	(25,8	r/s)
SAE J1349 net	193	Nm	(142	lbf/ft)
DIN 70020/6271	193	Nm	(142	lbf/ft)
No. cylinders	4			
Cubic capacity	2,73	l	(167	in ³)
Bore	91	mm	(3,6	in)
Stroke	105	mm	(4,1	in)

Electrical System

Rated voltage	12	V		
Battery voltage	12	V		
Battery capacity	88	Ah		
Alternator rating	840/60	W/A		
Starter motor output	2,2	kW	(3,0	hp)



BRAKING SYSTEM

Service brake: reliable dual braking system, acting upon all four wheels.

1. Wear-free, hydrostatic inching brake.
2. Central friction brake, actuated via "inch/brake pedal".
First stage of pedal application actuates the inching facility, the last third of pedal application applies the central friction brake.

Parking brake: central drum brake, acting upon all four wheels.



HYDRAULIC SYSTEM

Thermostatically controlled oil circuit with integrated cooling system and electrically switched fan.

Hydraulic control valve: double-acting control valve with three-spool system, with primary and secondary pressure valves.

1. Lifting function
2. Tilting function
3. Optional additional function for hydraulic QC:
lock, neutral, unlock
Preparation for operating hydraulic attachments with this function is available as an option.

Hydraulic oil filter: main stream filter cartridge with 10 µm filtration in the return-line. Suction filter for the drive assembly with 10 µm filtration. The filters can be replaced without emptying the tank.

Lifting frame: Z-bar linkage
2 Lift cylinders
1 Tilt cylinder

Hydraulic pump				
Flow	50	l/min	(13,2	US gal/min)
@ engine rpm	2200	r/min	(36,7	r/s)
Relief valve pressure	22	MPa	(3191	psi)
Lift time (loaded)	6,0	sec.		
Lowering time (empty)	3,0	sec.		
Dump time	1,0	sec.		
Crowd time	1,0	sec.		



DRIVETRAIN

Transmission: hydrostatic transmission, full power shift under load, both when changing direction (forward/reverse) and between first and second range. Maximum pushing force can be achieved in both ranges.

Inch/brake pedal for variable machine speed control.

Axles: all-wheel drive by two rigid axles.

Differential lock: hydraulically operated 100% differential locks in both axles.

Frame: solid front and rear frames, robot-welded. Center articulating-oscillating joint for optimum manoeuvrability and traction.

Oscillation at wheel, max.	250	mm	(9"	in)
Track	1382	mm	(52,4"	in)
Angle of oscillation	± 10	°		
Standard tires	Size	12.5-20		
	Rim	11 x 20		
Speed, max.ZL 602:				
1st range, forward/reverse	10,0	km/h	(6,2	mile/h)
2nd range, forward/reverse	20,0	km/h	(12,4	mile/h)
Speed, max. ZL602 SL:				
Work range				
1st stage, forward/reverse	8,0	km/h	(5	mile/h)
2nd stage, forward/reverse	18,0	km/h	(11,2	mile/h)
Travel range				
1st stage, forward/reverse	14,0	km/h	(8,7	mile/h)
2nd stage, forward/reverse	30,0	km/h	(18,6	mile/h)



SERVICE FILL CAPACITIES

Engine	10,5	l	(2,8	US gal)
Fuel tank	60,0	l	(15,9	US gal)
Front axle, total	10,0	l	(2,6	US gal)
Rear axle, incl. drop-box	11,0	l	(2,9	US gal)
Hydraulic tank, incl. hydraulic system	60,0	l	(15,9	US gal)



STEERING

Hydraulic steering. Central articulating-oscillating joint with damping effect.

Steering pump: gear-type pump.

Steering cylinder: 1 double-acting steering cylinder.

Steering				
Angle of articulation	± 39	°		
Steering pump				
Flow	24	l/min	(6,3	US gal/min)
@ engine rpm	2200	r/min	(36,7	r/s)
Relief valve pressure	15	MPa	(2176	psi)



An Allrounder from Zettelmeyer: as Versatile as your Requirements!

The ZL 602 is not only a top performer of classic earth-moving tasks - it has much more to offer!

Select from a wide range of attachments! With quick-change coupling, the machine is equipped for your job within seconds - all controlled from the operator's seat.

Expensive idle times are eliminated on construction sites, farms, gardening, landscaping or municipal jobs maximising use of your investment, and, irrespective of summer or winter -



It's always Zettelmeyer Season!



ZL 602 - Traction in Abundance!

The robust portal axles make the machine highly manoeuvrable and mobile in extremely difficult terrain. With 100 % differential locks and portal axles front and rear, the ZL 602 makes easy work of heavy ground conditions.

Slanted engine cover gives superb visibility, and the low maintenance articulating-oscillating joint ensures excellent manoeuvrability in tight quarters and uneven terrain.

On long hauls or when frequent and quick site changes are required, a ZL 602 SL, with its additional speed is just the right machine for the job.

The Lift-arm System adds Power to Digging Cycles!

In every application, you can take advantage of the proven Z-bar loader linkage. It shows extraordinary breakout force at the face, and excellent lifting force with the loading fork. The curvature of the lift arm is designed to cater for larger trucks both in dump height and reach for symmetric loading.



Extra Comfort for Increased Operator Performance

A suitable ergonomic environment is of paramount importance for good operator performance. The ZL 602 has a clearly designed cab interior.

Operator Comfort...

- Spacious, detachable cab
- Reliable heating and ventilation system
- 4-way adjustable operator's seat

... for smooth Working Cycles

- Clearly designed dashboard
- Audio-visual warning system
- Single lever control for hydraulics and differential lock
- Single pedal for inching and braking



Hydrostatic Drive - Constant Power you can rely on!

Hydrostatic drive maintains a constant drawbar pull even when the working hydraulics are at maximum pressure. The automatic drive allows the operator to concentrate fully on the job. Gears can be shifted under full load in work, cycles remain smooth and productivity stays constantly high. The hydrostatic drive serves as the main braking system - a further advantage, as this brake is virtually wear-free.

The Power Source: Environmentally-friendly Performance

The ZL 602 is equipped with the latest series Deutz 1011 engine. The result leaves nothing to be desired. High performance, economical fuel consumption along with low acoustic and low exhaust emissions. Therefore the ZL 602 has been honoured with the blue environment seal "environmentally-friendly - low noise".

Transverse engine allows easy access to major components. Daily maintenance and servicing are made simple by eye-level check points. Resultant time-savings leave you with cash-in-hand.

Exhaust Emissions ZL 602

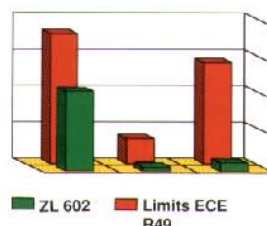

Exhaust emissions of ZL 602 are considerably lower than those required by ECE R49 limits

DIMENSIONS*



B	4285 mm	(14' 1" ft in)
C	2000 mm	(6' 6" ft in)
D	480 mm	(1' 7" ft in)
F	2615 mm	(8' 7" ft in)
G	950 mm	(3' 1" ft in)
J	2920 mm	(9' 7" ft in)
K	3120 mm	(10' 3" ft in)
O	53 °	
P	45 °	
R	50 °	
S	143 °	
U	200 mm	(0' 8" ft in)
X	1382 mm	(4' 6" ft in)
Y	1730 mm	(5' 8" ft in)
Z	2840 mm	(9' 4" ft in)
a ₂	3750 mm	(12' 1" ft in)
a ₃	1980 mm	(6' 6" ft in)
a ₄	± 39 °	

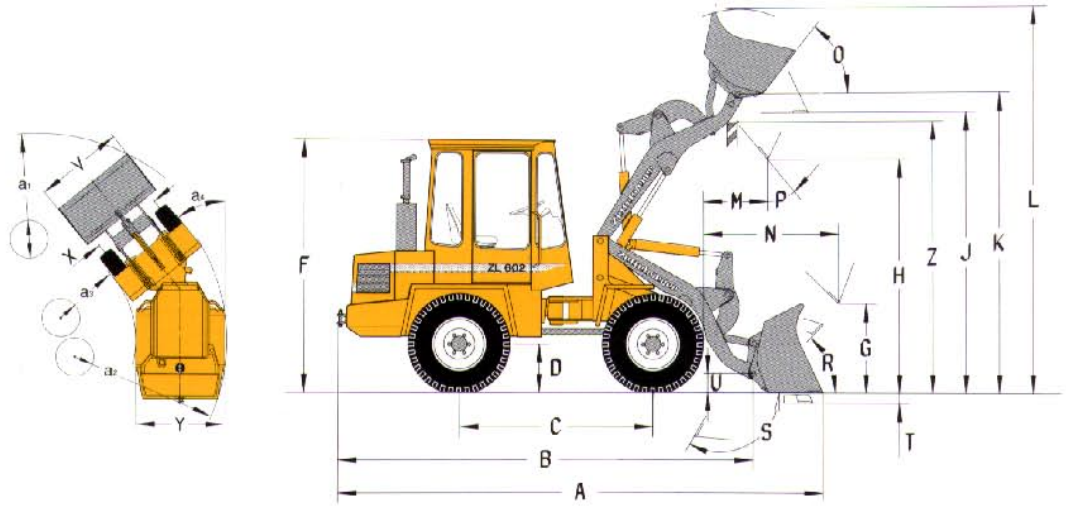

* measured with bucket 0,8 m³ (1,0 yd³), standard quick-change mounting and 12.5-20 tires

OPERATING DATA



Bucket Type		General Purpose Bucket		Light Material Bucket		4-in-1 Bucket	High-Tip Bucket
Mounting R (quick-change mounting standard equipment)		R		R		R	R
Edge: straight (G) with / without (+ / -) teeth		G + / -		G -		G +	G -
Capacity, heaped	m ³	0,8	0,9	1,3	1,5	0,75	1,2
	(yd ³)	(1,0)	(1,2)	(1,7)	(1,9)	(0,9)	(1,5)
Material density	kg/m ³	1900	1600	1100	900	1800	1000
	(lb/yd ³)	(3200)	(2700)	(1850)	(1500)	(3033)	(1650)
Static tipping load, straight (DIN)	kg	3510	3460	3300	3240	3170	3060
	(lb)	(7738)	(7628)	(7275)	(7143)	(6989)	(6746)
Static tipping load, full turn (39° DIN)	kg	3120	3080	2910	2880	2810	2720
	(lb)	(6878)	(6790)	(6415)	(6349)	(6195)	(5997)
Hydraulic lifting capacity, max.	kN	35,0	34,6	33,0	32,2	32,2	30,0
	(lbf)	(7868)	(7778)	(7419)	(7239)	(7239)	(6744)
Breakout force	kN	40,5	36,0	28,5	25,5	34,4	-
	(lbf)	(9105)	(8093)	(6407)	(5733)	(7733)	(-)
A Total length	mm	5150	5225	5405	5505	5260	5400
	(ft in)	(16' 10")	(17' 2")	(17' 9")	(18' 1")	(17' 3")	(17' 9")
L Lift height, max.	mm	4000	4040	4140	4270	3990	4660
	(ft in)	(13' 1")	(13' 3")	13' 7"	(14' 0")	(13' 1")	(15' 3")
V Bucket width	mm	1750	1900	1900	1900	1750	1900
	(ft in)	(5' 9")	(6' 3")	(6' 3")	(6' 3")	(5' 9")	(6' 3")
a ₁ Clearance circle	mm	8180	8300	8480	8550	8260	8980
	(ft in)	(26' 10")	(27' 3")	(27' 10")	(28' 1")	(27' 1")	(29' 6")
T Digging depth, max.	mm	100	100	100	100	100	100
	(ft in)	(0' 4")	(0' 4")	(0' 4")	(0' 4")	(0' 4")	(0' 4")
H Dump height	mm	2470	2420	2290	2220	2390	3560
	(ft in)	(8' 1")	(7' 11")	(7' 6")	(7' 3")	(7' 10")	(11' 8")
M Reach at max. height	mm	710	760	890	960	790	1120
	(ft in)	(2' 4")	(2' 6")	(2' 11")	(3' 2")	(2' 7")	(3' 8")
N Reach, max.	mm	1390	1440	1570	1640	1470	2075
	(ft in)	(4' 7")	(4' 9")	(5' 2")	(5' 6")	(4' 10")	(6' 10")
	kg	4600	4630	4690	4720	4800	4950
Operating Weight	(lb)	(10141)	(10207)	(10340)	(10406)	(10581)	(10913)

STANDARD EQUIPMENT

Cab, Exterior

Removable ROPS-cab with flexible mountings

Walk-through cab
Lockable doors

Tinted safety glass (windscreen)
Windscreen wiper, front and rear
Sliding window in the left door
Door stops
External rear view mirrors (right and left)

Cab, Interior

4-way adjustable driver's seat
Seat belt

Sunvisor
Heater with air-filter and defroster
Cab ventilation
Cab lighting
Storage box in the cab
Tool box

Instrument Panel

with symbols:
Instrument lighting
12 V power socket
Horn
Safety start

Gauges:
Fuel gauge
Hour meter
Drive system oil temperature

Indicator lamps for:
Direction indicator
Parking brake
Main beam
Pre-heater
Battery charging
Differential locks
Hazard warning flashers

Central audio-visual alarm:
Engine temperature
Engine oil pressure
Drive system oil temperature
Air filter restriction
Parking brake

Exterior Lighting

Main head lights (Halogen):
full/dipped/asymmetrical
Parking lights
Rear lights
Brake lights
Direction indicators
Hazard warning lights

Powertrain

Diesel engine with direct fuel injection
Cold start aid
Dry-type air filter

Alternator 60 A

Hydrostatic drive
Lockable 100% differential locks

Tires 12.5 -20

Gear-type pumps
Control valve three-spool system
Third hydraulic circuit

Service and Maintenance

Tool kit

Working Equipment

Single lever control
Bucket level indicator
Hydraulic quick-change attachment carrier

Carriage Body

Fenders and mudguards, front and rear
Lockable engine hood
Lockable fuel-tank cap
Vertical exhaust
Towing device

Complete system in accordance with German road traffic regulations
Sound insulation acc. to EC-guidelines
Working safety disc acc. to TBG

OPTIONAL EQUIPMENT

Cab

Handthrottle
Hand control inch valve
Heating independent of engine
Radio

Windscreen washer, front and rear
Sliding window in the right door
Hinge-out skylight

Safety

FOPS plate
Protective guards for
Main head lights
Working lights
Rear lights
Rotating beacon
Audible reverse alarm
Counterweight

Powertrain

Pre-heater
Catalytic converter
Extra fuel filter
Pre-cleaner with ejector
Two-stage air filter (oil bath)

Service and Maintenance

Wheel nut wrench

Working Equipment

Working lights (front and rear)
ZLS load stabilizer
Extended lift arms

PTO
Extra hydraulics, rear
Additional hydraulics for attachment carrier
4th hydraulic circuit
Hydraulic circuit w. additional pump

ATTACHMENTS

Buckets

of various sizes
0,8 - 1,5 m³ (1,0 - 1,9 yd³)
with or without teeth

Wide range of bucket types, eg
Light material bucket (with or without teeth)

High-tip bucket (without teeth)
Side-tip Bucket (without teeth)
4-in-1 bucket (with teeth)
Brick bucket (with teeth)
Horticultural bucket
Bolt-on cutting edge

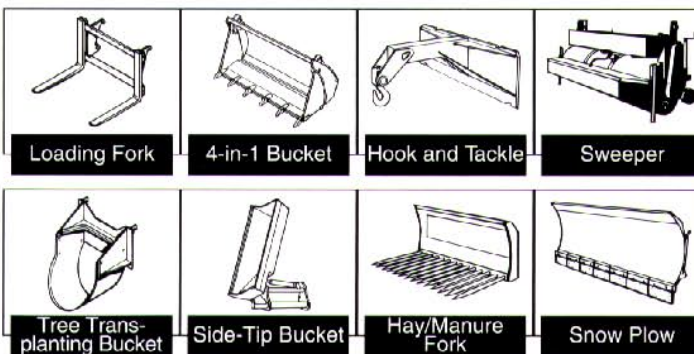

Further buckets and attachments available on request.

Selection of Attachments, eg for

Timber Industry:
Log grapple
Loading fork with log grapple
Road building/industry:
Loading fork
Hook and tackle
Municipal application:
Sweeper
Angle dozer blade
Snow plow
Horticulture and agriculture:
Hay/Manure fork
Front scarifier

*Under our policy of continuous product improvement, we reserve the right to change specifications and design without prior notice.
The illustrations do not necessarily show the standard version of the machine.*