

Mining Excavator

R 9250

Operating Weight with Backhoe Attachment:	250,000 kg / 551,150 lb
Operating Weight with Shovel Attachment:	253,500 kg / 558,870 lb
Engine Output:	960 kW / 1,287 hp
Bucket Capacity:	13.00 - 17.00 m ³ / 17.0 - 22.2 yd ³
Shovel Capacity:	13.00 - 17.00 m ³ / 17.0 - 22.2 yd ³



LIEBHERR

R 9250

Operating Weight with Backhoe Attachment:	250,000 kg / 551,150 lb
Operating Weight with Shovel Attachment:	253,500 kg / 558,870 lb
Engine Output:	960 kW / 1,287 hp
Bucket Capacity:	13.00 - 17.00 m ³ / 17.0 - 22.2 yd ³
Shovel Capacity:	13.00 - 17.00 m ³ / 17.0 - 22.2 yd ³



Productivity and Efficiency

Liebherr's R 9250 mining excavator integrates the latest technology to perform efficiently in all types of mining environments. Even under the hardest conditions, it achieves high productivity. Always ready for job, the R 9250 is your key to the lowest operating and owning cost per tonne.

Reliability

More than 50 years of experience in designing and manufacturing hydraulic excavators are the basis for the outstanding reliability of the R 9250. This excavator combines innovative solutions, excellent design and Liebherr long-life components, ensuring maximum availability and performance throughout the whole equipment life.

Customer Support

On site, Liebherr's customer support delivers tailor-made professional solutions to your project specifics and site requirements. Liebherr offers a partnership with the goal of mining more for less.

Operating and Servicing

The R 9250's operator cab creates a comfortable and ergonomic working environment. The electronic machine controls assure the best operator performance throughout each shift. Furthermore, the ergonomic component access and long service intervals assist the service team to ensure more uptime.

Safety & Environment

The Liebherr R 9250 provides uncompromising safety for operators and maintenance crews, with innovative technologies integrated into the machine.





Electronic Cylinder End Position Control

- Patented system based on electronic control
- Smooth attachment movements even when working close to cylinder end position
- No shocks when reaching attachment end position
- No oil heating when reaching cylinder end position
- Energy saving by limiting the oil flow
- Allows the operator to focus on loading



Productivity and Efficiency

Liebherr's R 9250 mining excavator integrates the latest technology to perform efficiently in all types of mining environments. Even under the hardest conditions, it achieves high productivity. Always ready for job, the R 9250 is your key to the lowest operating and owning cost per tonne.

Reach a New Level of Productivity

Liebherr Electronic Machine Control Litronic

Liebherr's electronic machine control Litronic contributes to fast loading cycles and easy control, even if multiple movements are required at the same time. The electronic control of the hydraulic system enhances pressure and flow distribution as a function of the machine movement. Thanks to the electronic cylinder end position control the operator can fully focus on the job.

High Digging Forces

The production-tailored attachment kinematics combined with a mining-optimized bucket shape ensure the highest crowd and breakout forces. Even under tough conditions Liebherr's R 9250 high digging force allows easy bucket penetration and high bucket fill factors achieving high productivity.

Closed Loop Swing Circuit

With an independent swing circuit the machine allows the maximum swing torque whilst retaining the full oil flow for the working circuit.

Compact Machine Design

Liebherr's excavator design is well-balanced and provides best machine stability. The high weight distribution towards the undercarriage contributes to an efficient utilization of the strong digging forces and a favorable power to weight ratio of the uppercarriage and attachment.

Efficiency for Less Cost

Efficient Cooling System

Liebherr's large dimensioned cooling system reduces fan power consumption and ensures an ideal machine temperature. The hydrostatic fans operate always on the required level.

High Hydraulic Efficiency

The high pressure level of Liebherr hydraulic system together with the optimized pipe and hose layout maximize the usable power transmission. The Pressure Less Boom Down function combined with the oil regeneration on the attachment saves energy and reduces swing back time.

Automatic Idle Control

The electronic control of the hydraulic system and engine allows automatic idle mode contributing to less fuel consumption and load on the engine.

Advanced Attachment Kinematics

- Advanced attachment technology and design for optimized digging force distribution
- Precise fast and slow machine movement control with electronic oil flow control



Hydraulic Efficiency

- Pressure Less Boom Down Function for fast cylinder retraction without power consumption
- Regeneration for optimized oil volume flow
- Low fan power consumption

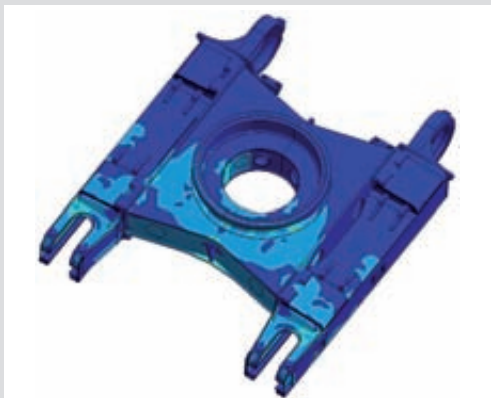

Finite Element Analysis (FEM)

- Multibody simulations
- Fatigue calculations for longest possible lifetimes



Reliability

More than 50 years of experience in designing and manufacturing hydraulic excavators are the basis for the outstanding reliability of the R 9250. This excavator combines innovative solutions, excellent design and Liebherr long-life components, ensuring maximum availability and performance throughout the whole equipment life.

Experience Liebherr Quality

Over 50 Years of Experience

Since 1954, Liebherr has been designing, manufacturing and servicing crawler mounted excavators used in toughest applications. Like its predecessors, Liebherr's R 9250 benefits from this long-time experience in the customer-focused design with modern engineering solutions and extensive mining knowledge.

Quality Management

Liebherr's quality processes commence with the machine design and simulations. Liebherr meets the highest industry standards for special selections of steels and selection of special casting materials. During manufacturing and assembly, Liebherr quality management follows all manufacturing steps, ensuring highest quality of each machine delivered. Liebherr hydraulic excavator plants are ISO 9001 certified.

Heavy Duty Excavator

First-class components and machine steel structures ensure a high machine reliability, even in hard mining conditions.

Advanced Design of All Mining Applications

Machine Design

Liebherr's design processes include the latest and product specific numerical engineering tools, such as Finite Element Analyses, Fatigue Calculations, Torque and Displacement Analysis and Multibody Simulations. These modern techniques allow reliable engineering solutions for series and special applications.

Specific Solutions

As each project is unique, Liebherr is developing and supplying solutions to ensure performance and reliability in specific mining environments. Liebherr's R 9250 can be customized to operate in regions with temperatures of down to -40°C / -40°F or up to 55°C / 131°F , as well as in high-altitude regions of up to 4,500 m above sea level. Liebherr also offers specific bucket-tailored solutions for each type of application.



Liebherr Buckets

- The right size for each application
- Robust structural design adapted to machine's high digging and breakout forces
- Customized and site-specific wear packages configuration
- Face shovel and backhoe configuration available



Liebherr Components

- Major components developed and manufactured in-house
- Designed specifically for mining operations
- Liebherr Service Exchange Program



Service Exchange Units (SEU)

Rebuild programs for components are conducted by Liebherr-certified repair shops, using best practice guidance to ensure:

- Maximum component life
- Long-term reliability
- High performance
- Cost-efficiency
- High quality



Customer Support

On site, Liebherr's customer support delivers tailor-made professional solutions to your project specifics and site requirements. Liebherr offers a partnership with the goal of mining more for less.

Your Mining Partner

Parts Logistics and Services

Liebherr parts and service follow the machine into the field with international logistics platforms ensuring parts supply and maintenance services worldwide.

Customized Service and Product Support

Depending on specific requirements, Liebherr offers tailored support solutions integrating parts exchange and management agreements, service and maintenance on site or maintenance management agreements.

Service Exchange Units

Rebuild programs for components are conducted by Liebherr-certified repair shops, ensuring rebuilt component life and reliability match new component performance expectations.

Complete Training Solutions

Dedicated to mining the Liebherr training team provides operator and maintenance staff training programs to allow cost-efficient and safe operations. Liebherr offers customized on-site training courses according to your needs.

Factory Support

Service Engineering

Liebherr design and field service engineers accompany the excavators throughout the whole machine life. Liebherr's sales and service organizations and the Liebherr factories' product engineering groups provide fast and proactive support to the mining industry.

Service Tools

Liebherr affords service tools for excavator-specific maintenance which ensure safe working even when handling large excavator components.



Liebherr Service Tools

- Fast component replacement
- Designed specifically for requirements on Liebherr machines
- High operational safety
- Cost-efficiency for service operations
- Usable on different excavator sizes



Liebherr Training Programs

Competence-based training, employing an interdisciplinary learning strategy:

- Liebherr Mining Training Centers
- Available in different languages
- Customized training courses on site



Electronic Machine Controls and Diagnostics

- Electronic joysticks for easy machine operations
- LCD operator display for machine control and easy service diagnostic
- Each lubrication circuit can be set individually through operator's dashboard



Operating and Servicing

The R 9250's operator cab creates a comfortable and ergonomic working environment. The electronic machine controls assure the best operator performance throughout each shift. Furthermore, the ergonomic component access and long service intervals assist the service team to ensure more uptime.

Operator Workplace

Comfortable Working Environment

The R 9250's spacious cab offers ideal working conditions and first-class comfort. The adjustable air suspension seat fits to individual needs. Best visibility over the whole working environment is provided by the enhanced position of the cab. The hanging arch hose arrangement allows to oversee large areas of the uppercarriage. Additionally a camera system shows areas that can't be observed directly. The cab's effective insulation creates a quiet working environment for maximum productivity.

Ergonomic Control Elements

The configuration and placement of operator control elements and monitoring displays are perfectly coordinated to support the productive performance. The electronic control is easy and intuitive to use. The dashboard and machine control panel are easy to access and arranged for fast overview on major machine functions.

Easy Serviceability

Ergonomic Service Access

The Liebherr R 9250 provides ergonomic component access for fast and efficient service. All service points are within reach through large catwalks and walkways. The centralized drop down flap allows easy and safe refilling and exchange of all service fluids, preventing spillage and reducing contamination by dust. The electronic health monitoring system assists in trouble-shooting and maintenance tasks. Liebherr excavators are equipped with louvers for easy access of ground based support tools.

Extended Service Intervals

Designed for mining operations the R 9250 offers all features for extended machine services intervals. The filtration systems with integrated by pass hydraulic oil filters and the large grease systems are only two of them. The fuel tank enables an operation beyond 24 hours prior re-fuelling.



Comfort in Cab

- Tinted safety glass all-around with heavy duty sun louvers on all windows
- Pressurized to prevent dust penetration
- Low vibrating and soundproof
- Operator eye level of 6.35 m / 20'83" for clear view of truck body and overall digging area



Extended Service Intervals

- Large fuel tank capacity of 5,440 l / 1,434 gal for high machine endurance
- Oil sample points oil analyses
- Air filter cyclone pre-cleaner with automatic dust ejection
- Automatic single-line central lubrication system
- Extended grease tank (optional)

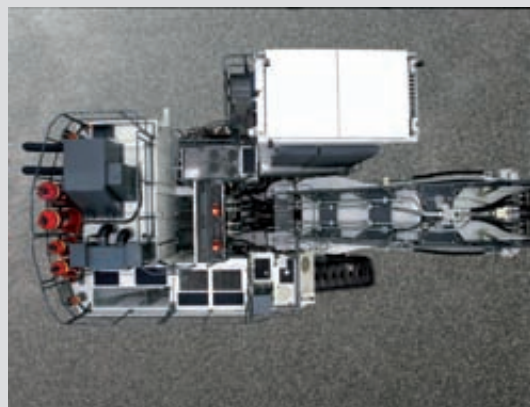

Safe Machine Access

- Powered access ladder with perforated steps
- Access ladders and catwalks feature handrails and slip-resistant surfaces
- Emergency egress with handrail at the front of the excavator



Safety and Environment

The Liebherr R 9250 provides uncompromising safety for operators and maintenance crews, with innovative technologies integrated into the machine.

Safety Integrated Design

Easy and Safe Machine Access

All railings and catwalks are laid out to easily access all relevant machine areas. An optional 45° stair helps accessing the machine comfortably. In case of emergency stops the stair is automatically activated.

Protected Operator and Service Crew

The cab has an integrated FOPS structure. The armored front and attachment side windows create a safe working environment for operators. All other windows are of laminated safety glass. Emergency stop arrangements in the cab as well as in the pump compartment, valve bank, engine compartment and at ground level ensure safe maintenance tasks. Safety standards are achieved by a separated engine and pump compartment, heat insulation on turbochargers and on the exhaust system as well as by the use of heavy duty high resistant hydraulic hoses.

Environmental Care

Ecological Features

Throughout the whole design and manufacturing process of Liebherr machines, environmental protection is given high priority. Material used for machine assembly is recyclable at 95 %. The hydraulic system allows the use of biodegradable hydraulic oils. The automatic idle mode contributes to less fuel consumption and less load on the engine resulting in reduced CO₂ emissions.

Electrical Drive for Even More Power and Efficiency

Liebherr's fully integrated optional electrical drive system allows for high operating efficiency and additional power. Due to the long service intervals of electrical motors, uptime can be enhanced while maintenance costs are decreased. The silent electrical drive contributes to health and safety requirements.

Operation under Sound Restriction

Liebherr provides solutions for operations close to residential areas with machine-specific sound attenuation packages. The approach is based on both removal of noise at the source and passive sound attenuation resulting in low machine noise emissions.

Electric Motor

- High efficiency
- Long service intervals
- Reduced maintenance costs
- Higher component lifetime due to less vibration
- Silent electric drive contributes to health, safety and environmental care



Sound Attenuation Kit

- Full integration into machine structure
- Noise-optimised fan regulation
- Long life sound attenuation on doors and walls
- Soundproof louvers
- Valve bank covering

Technical Data



Engine

1 Cummins diesel engine

Rating per
SAE J 1995 _____ 960 kW/1,287 hp at 1,800 rpm

Model _____ QSK45 (Tier 1)

Type _____ 12 cylinder turbocharged V-engine
after-cooler
two separate water cooling circuits
direct injection system

Displacement _____ 45 l/2,745 in³

Bore/Stroke _____ 159/190 mm/6.26/7.48 in

Engine cooling system _____ fans driven via hydraulic piston motor

Air cleaner _____ dry-type air cleaner with pre-cleaner, with automatic dust ejector, primary and safety elements

Fuel tank _____ 5,440 l/1,434 gal

Electrical system
Voltage _____ 24 V

Batteries _____ 6 x 170 Ah/12 V

Alternator _____ 24 V/260 Amp

Engine idling _____ sensor controlled

Electronic engine control system _____ engine speed sensing over the entire engine RPM range. Provides integration of engine with other machine systems



Electric Motor (optional)

1 electric motor

Power output _____ 1,050 kW/1,408 hp

Type _____ 3 phase AC squirrel cage motor

Voltage _____ voltage on request

Frequency _____ 50 Hz (or 60 Hz – dependent on country)

Revolutions _____ 1,500 rpm or 1,800 rpm

Motor cooling _____ integrated air-to-air heat exchanger

Starting method _____ reduction of inrush current



Hydraulic System

Hydraulic pumps
for attachment and
travel drive _____ 3 variable flow axial piston pumps

Max. flow _____ 2 x 771 l/min. + 1 x 579 l/min./
2 x 204 gpm + 1 x 153 gpm

Max. hydr. pressure _____ 320 bar/4,640 psi

Hydraulic pump
for swing drive _____ 2 reversible swash plate pumps, closed-
loop circuit

Max. flow _____ 2 x 352 l/min./2 x 93 gpm

Max. hydr. pressure _____ 320 bar/5,076 psi

Pump management _____ electronically controlled pressure and flow
management with oil flow optimisation

Hydraulic tank capacity _____ 2,281 l/602 gal

Hydraulic system
capacity _____ 4,050 l/1,070 gal

Hydraulic oil filter _____ 1 high pressure safety filter after each high
pressure pump + fine filtration of entire
return flow

Hydraulic oil cooler _____ cooler with temperature controlled fans
driven via hydraulic piston motor



Hydraulic Controls

Servo circuit _____ independant, electric over hydraulic pro-
portional controls of each function

Emergency control _____ via accumulator for all attachment func-
tions with stopped engine

Power distribution _____ via monoblock control valves with inte-
grated primary relief valves and flanged on
secondary valves for travel

Flow summation _____ to attachment and travel drive

Control functions
Attachment and
swing _____ proportional via joystick levers

Travel _____ proportional via foot pedals or hand levers

Bottom dump bucket _____ proportional via foot pedals



Electric System

Electric isolation _____ easy accessible battery isolations

Working lights _____ high brightness halogen lights:
– 2 on working attachment
– 1 on RHS of uppercarriage
– 3 on LHS of uppercarriage
– 2 on counterweight
Xenon lights in option

Emergency stop switches _____ at ground level, in hydraulic compartment,
in engine compartment and in operator cab

Electrical wiring _____ heavy duty execution in IP 65 standard for
operating conditions of – 50 °C to 100 °C/
– 58 °F to 212 °F



Swing Drive

Hydraulic motor _____ 2 Liebherr axial piston motors

Swing gear _____ 2 Liebherr planetary reduction gears

Swing ring _____ Liebherr, sealed triple roller swing ring,
internal teeth

Swing speed _____ 0 – 4.4 rpm

Swing-holding brake _____ hydraulically actuated, maintenance-free,
multi-disc brakes integrated in each swing
gear



Uppercarriage

Design _____ torque resistant designed upper frame in
box type construction for superior strength
and durability

Attachment mounting _____ parallel longitudinal main girders in box-
section construction

Machine access _____ on the cab side with a hydraulically driven
access ladder, additional emergency ladder
in front of the cab



Service Flap

Design _____ hydraulically actuated service flap, easily
accessible from ground level to allow:
– fuel fast refill
– engine oil quick change
– swing ring teeth grease barrel refilling via
grease filter
– attachment/swing ring bearing grease
barrel refilling via grease filter
– hydraulic oil refill
– hydraulic oil draining
– splitterbox oil refill
– windshield wash water refilling

Other coupler type on request

Technical Data



Operator's Cab

Design	resiliently mounted, sound insulated, large windows for all around visibility, integrated falling object protection FOPS
Operator's seat	suspended, body-contoured with shock absorber, adjustable to operator's weight
Cabin windows	20.5 mm/0.8 in tinted armored glass for front window and right hand side windows, all other windows in tinted safety glass, high pressure windshield-washer system 75 l/20 gal watertank, sun louvers on all windows in heavy duty design
Heating system/ Air conditioning	heavy duty, high output air conditioner and heater unit
Cabin pressurization	ventilation with filter
Controls	joystick levers integrated into armrest of seat
Monitoring	via LCD-Display, data memory
Rear vision system	camera installation on counterweight and right-hand side of the uppercarriage displayed over an additional LCD-display
Automatic engine shut off	engine self-controlled shut off
Destroking of main pumps	in case of low hydraulic oil level
Safety functions	additional gauges with constant display for: engine speed, hourmeter, voltmeter, safety mode for engine speed control and pump regulation
Noise level (ISO 6396)	Diesel: L_{pa} (inside cab) = 77,2 dB(A) with oil/water fans at 100 % and AC fan at 65 % Electric: L_{pa} (inside cab) = 69,7 dB(A) with oil/water fans at 100 % and AC fan at 65 %



Undercarriage

Design	3-piece undercarriage, box type structures for center piece and side frames, stress relieved
Hydraulic motor	2 axial piston motors per side frame
Travel gear	Liebherr planetary reduction gear
Travel speed	0 - 2.3 - 3.0 km/h/0 - 1.40 - 1.90 mph
Parking brake	spring engaged, hydraulically pressure released wet multi-disc brakes for each travel motor, maintenance-free
Track components	D 12, maintenance-free
Track rollers/ Carrier rollers	9/2
Automatic track tensioner	hydraulic and grease tensioner
Transport	undercarriage side frames are removable



Central Lubrication System

Type	Lincoln Centromatic lubrication system, for the entire attachment/swing ring bearing and teeth
Grease pumps	Lincoln Flowmaster pump plus separate pump for swing ring teeth
Capacity	80 l/21.1 gal bulk container for attachment/swing ring bearing, separated 15 l/4.0 gal bulk container for swing ring teeth
Refill	via the service flap for both containers, fill line with grease filters
Option	200 l/53 gal grease bulk container for attachment/swing ring bearing



Attachment

Design	box-type structure with large steel castings in all high-stress areas
Stick	wear protection underneath lower beam plate
Pivots	sealed and floating pins
Hydraulic cylinder	Liebherr design, sealed bearings, electronically controlled end-cushioning
Hydraulic connections	pipes and hoses equipped with SAE split-flange connections
Pivots bucket-to-stick	
Pivots bucket-to-link	O-ring sealed and completely enclosed
Kinematics	Liebherr parallel face shovel attachment geometry, electronic controlled end-cushioning

Dimensions

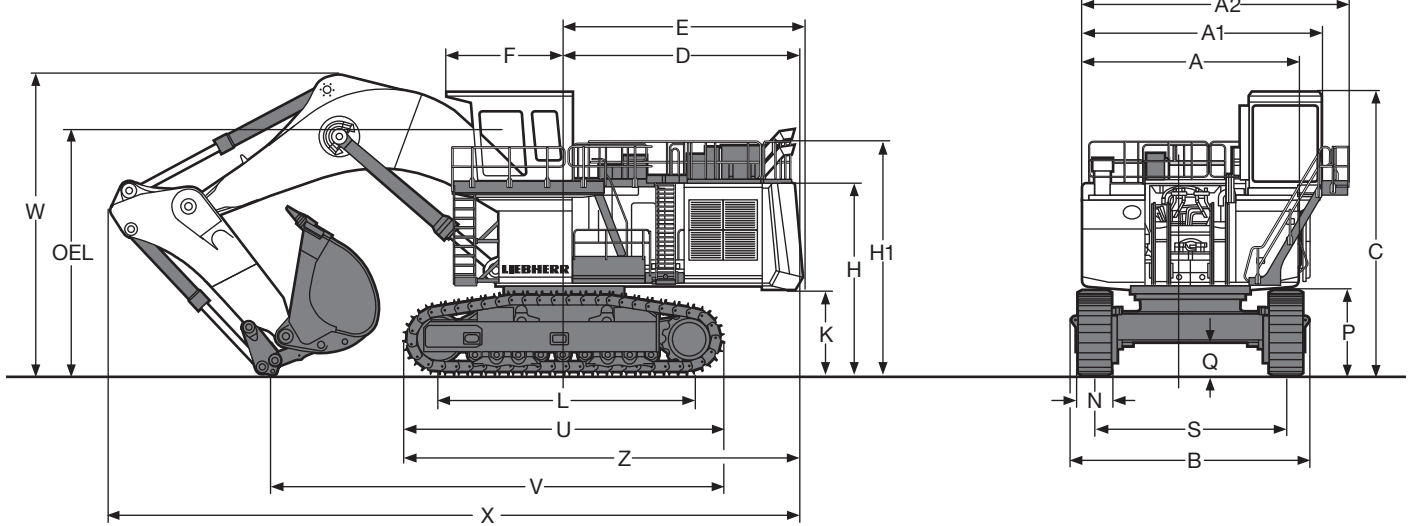

	mm/ft in
A	5,500/18'
A1	6,100/20'
A2	6,800/22' 3"
C	7,250/23' 9"
D	6,100/20'
E	6,140/20' 1"
F	2,993/ 9' 9"
H	4,905/16' 1"
H1	6,000/19' 8"
K	2,205/ 7' 2"
L	6,400/20'11"

	mm/ft in
P	2,200/ 7' 2"
Q	870/ 2'10"
S	4,900/16'
U	8,240/27'
Z	10,240/33' 7"
N	850/ 2' 9"
B	6,040/19' 9"
V	11,600/38'
W	7,800/25' 7"
X	17,800/58' 4"
OEL	Operator's Eye Level
	6,350/20' 9"

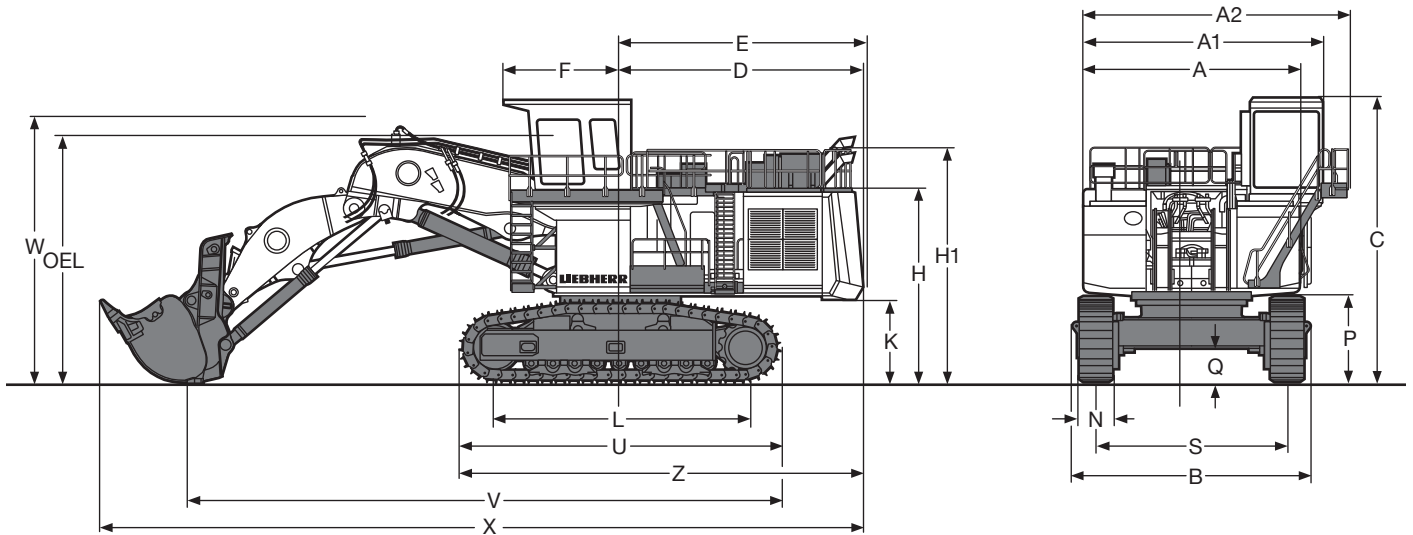

	mm/ft in
A	5,500/18'
A1	6,100/20'
A2	6,800/22' 3"
C	7,250/23' 9"
D	6,100/20'
E	6,140/20' 1"
F	2,993/ 9' 9"
H	4,905/16' 1"
H1	6,000/19' 8"
K	2,205/ 7' 2"
L	6,400/20'11"

	mm/ft in
P	2,200/ 7' 2"
Q	870/ 2'10"
S	4,900/16'
U	8,240/27'
Z	10,240/33' 7"
N	850/ 2' 9"
B	6,040/19' 9"
V	17,400/57'
W	6,700/21'11"
X	19,600/64' 3"
OEL	Operator's Eye Level
	6,350/20' 9"

Backhoe Attachment

with Gooseneck Boom 9.00 m/29'6"

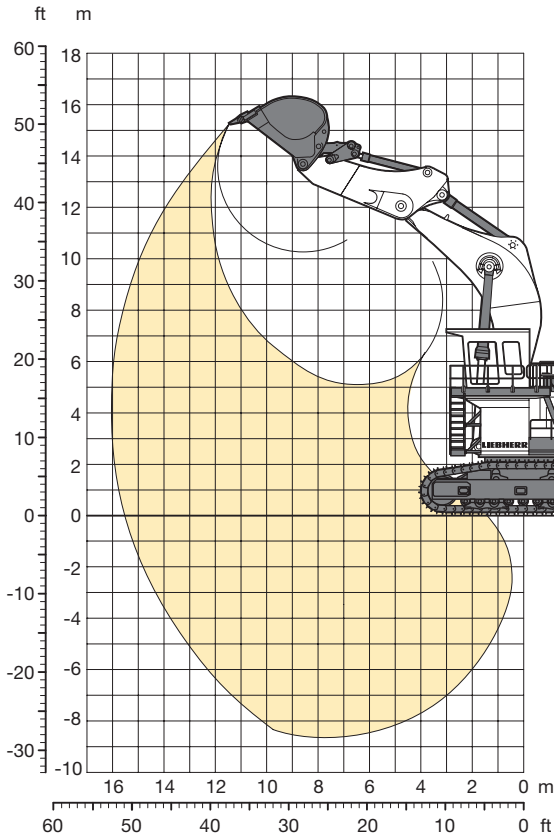

Digging Envelope

Stick length	4.00 m/13' 1"
Max. reach at ground level	15.50 m/50'10"
Max. teeth height	15.20 m/49'10"
Max. dump height	10.30 m/33' 9"
Max. digging depth	8.70 m/28' 6"
Max. digging force (SAE)	780 kN/175,351 lbf
Max. breakout force (SAE)	859 kN/193,111 lbf

Operating Weight and Ground Pressure

The operating weight includes the basic machine with backhoe attachment and a 15.00 m³/19.6 yd³ bucket.

Pad width	mm/ft in	850/2'9"
Weight	kg/lb	250,000/551,155
Ground pressure	kg/cm ² / psi	2.08/29.58

Buckets

For materials classe according to VOB, Section C, DIN 18300		< 5	< 5	5 – 6	5 – 6	5 – 6	7 – 8
Typical operation according to VOB, Section C, DIN 18300		GP	GP	HD	HD	HD	XHD
Capacity ISO 7451	m ³	16.00	17.00	13.00	15.00	17.00	13.50
	yd ³	20.93	22.24	17.00	19.62	22.24	17.66
Suitable for material up to a specific weight of	t/m ³	1.8	1.7	2.1	1.8	1.6	1.8
	lb/yd ³	3,035	2,867	3,541	3,035	2,698	2,867
Cutting width	mm	3,300	3,500	3,000	3,120	3,500	3,160
	ft in	10'9"	11'5"	9'10"	10'2"	11'5"	10'4"
Weight	kg	14,300	14,800	14,300	15,500	16,400	19,200
	lb	31,526	32,628	31,526	34,172	36,156	42,329

GP: General purpose bucket with Esco 85SV2 teeth

HD: Heavy-duty bucket with Esco 85SV2 teeth

XHD: Heavy-duty rock bucket with Esco 85SV2 teeth

Shovel Attachment

with Shovel Boom 6.37 m/20'9"

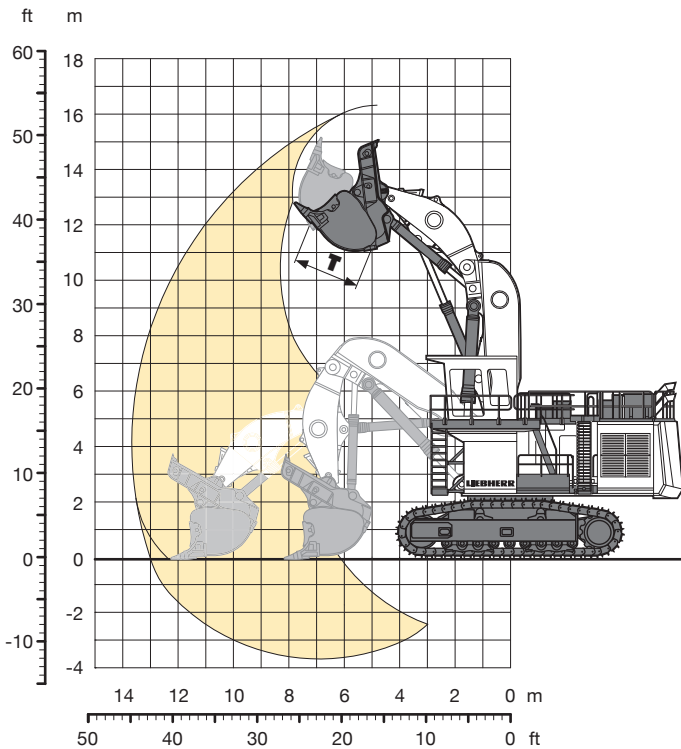

Digging Envelope

Stick length	4.20 m/13'9"
Max. reach at ground level	13.00 m/42'7"
Max. dump height	11.00 m/36'
Max. crowd length	4.00 m/13'1"
Bucket opening width T	2.15 m/ 7'
Crowd force at ground level	1050 kN/236,049 lbf
Max. crowd force	1210 kN/272,019 lbf
Max. breakout force	935 kN/210,196 lbf

Operating Weight and Ground Pressure

The operating weight includes the basic machine with shovel attachment and a 15.00 m³/19.6 yd³ bucket.

Pad width	mm/ft in	850/2'9"
Weight	kg/lb	253,500/558,871
Ground pressure	kg/cm ² / psi	2.12/30.15

Bottom Dump Buckets

For materials classe according to VOB, Section C, DIN 18300		< 5	< 5	5 – 6	5 – 6	7 – 8	7 – 8
Typical operation according to VOB, Section C, DIN 18300		GP	GP	HD	HD	XHD	XHD
Capacity ISO 7546	m ³	17.00	7.70	13.00	15.00	11.00	13.00
	yd ³	22.24	10.07	17.00	19.62	14.39	17.00
Suitable for material up to a specific weight of	t/m ³	1.6	1.7	2.1	1.8	2.3	1.8
	lb/yd ³	2,698	2,867	3,541	3,035	3,879	3,035
Cutting width	mm	3,700	2,900	3,700	3,700	3,700	3,700
	ft in	12'1"	9'6"	12'1"	12'1"	12'1"	12'1"
Weight	kg	27,000	11,000	27,000	27,000	28,000	29,000
	lb	59,525	24,251	59,525	59,525	61,729	63,934
Wear kit level		I	I	II	II	III	III

GP: General purpose bucket with Esco 85SV2 teeth
 HD: Heavy-duty bucket with Esco 85SV2 teeth
 XHD: Heavy-duty rock bucket with Esco 85SV2 teeth

Level I: For non-abrasive materials, such as limestone, without flint inclusion, shot material or easily breakable rock, i.e., deteriorated rock, soft limestone, shale, etc.

Level II: For preblasted heavy rock, or deteriorated, cracked material (classification 5 to 6, according to DIN 18300)

Level III: For highly-abrasive materials such as rock with a high silica content, sandstone etc.

Component Dimensions and Weights

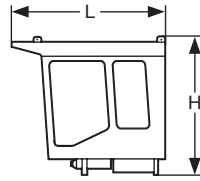

Cab

L Length	mm/ft in	3,215/10'6"
H Height	mm/ft in	2,885/ 9'5"
Width	mm/ft in	1,900/ 6'2"
Weight	kg/lb	3,400/7,496

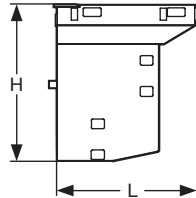

Cab Elevation

L Length	mm/ft in	2,315/7' 7"
H Height	mm/ft in	2,457/8'
Width	mm/ft in	1,496/4'10"
Weight	kg/lb	2,802/6,177

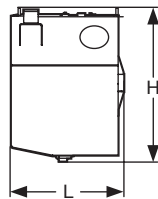

Fuel Tank

L Length	mm/ft in	2,550/ 8' 4"
H Height	mm/ft in	3,450/11' 3"
Width	mm/ft in	3,045/ 9'11"
Weight	kg/lb	1,950/4,299

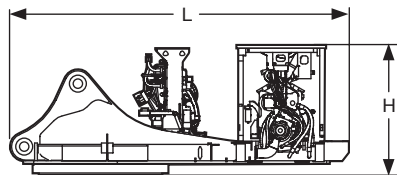

Rotation Deck (with swing ring, swing gears, control valve bracket and engine with pumps)

L Length	mm/ft in	7,670/25'1"
H Height	mm/ft in	2,855/ 9'4"
Width	mm/ft in	4,099/13'5"
Weight	kg/lb	45,000/99,208

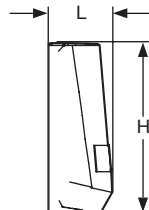

Counterweight

L Length	mm/ft in	1,025/ 3' 4"
H Height	mm/ft in	2,730/ 8'11"
Width	mm/ft in	6,000/19' 8"
Weight	kg/lb	25,320/55,821

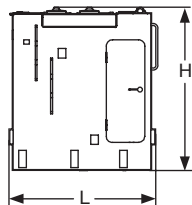

Hydraulic Tank

L Length	mm/ft in	2,325/7'7"
H Height	mm/ft in	2,582/8'5"
Width	mm/ft in	1,354/4'5"
Weight	kg/lb	5,390/11,883

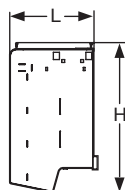

Oil Radiator Installation

L Length	mm/ft in	1,595/5'2"
H Height	mm/ft in	2,660/8'8"
Width	mm/ft in	2,070/6'9"
Weight	kg/lb	1,750/3,858

Component Dimensions and Weights

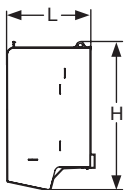

Water Radiator Installation

L Length	mm/ft in	1,565/5' 1"
H Height	mm/ft in	2,660/8' 8"
Width	mm/ft in	2,430/7'11"
Weight	kg/lb	2,980/6,570

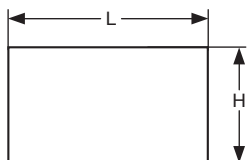

Small Pieces

L Length	mm/ft in	4,500/14'9"
H Height	mm/ft in	2,600/ 8'6"
Width	mm/ft in	2,000/ 6'6"
Weight	kg/lb	4,500/9,921

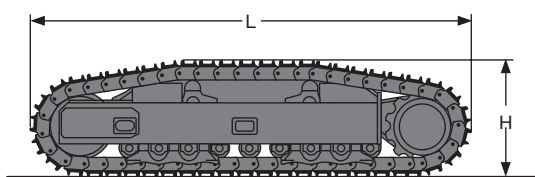

Side Frame (two)

L Length	mm/ft in	8,240/27'
H Height	mm/ft in	2,180/ 7'1"
Width over travel drive	mm/ft in	2,190/ 7'2"
Width without travel drive	mm/ft in	1,335/ 4'4"
Weight	kg/lb	2 x 37,000/2 x 81,571

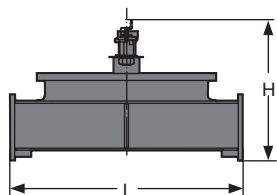

Undercarriage Central Girder

L Length	mm/ft in	3,650/11'11"
H Height	mm/ft in	2,190/ 7' 2"
Width	mm/ft in	4,420/14' 5"
Weight	kg/lb	18,500/40,785

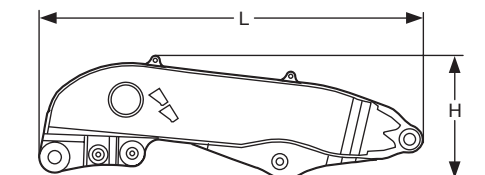

Shovel Boom

L Length	mm/ft in	7,000/22'11"
H Height	mm/ft in	2,600/ 8' 6"
Width	mm/ft in	3,300/10' 9"
Weight	kg/lb	19,240/42,417

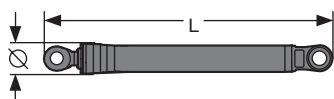

Shovel Hoist Cylinder (two)

L Length	mm/ft in	4,300/14'1"
Ø Diameter	mm/ft in	500/ 1'7"
Weight	kg/lb	2 x 3,088/2 x 6,808

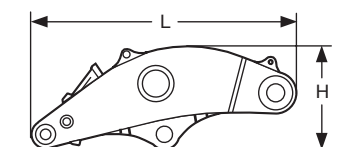

Shovel Stick

L Length	mm/ft in	4,800/15'8"
H Height	mm/ft in	2,000/ 6'6"
Width	mm/ft in	3,100/10'2"
Weight	kg/lb	11,750/25,904

Component Dimensions and Weights

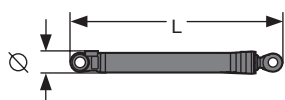

Crowd Cylinder (two)

L Length	mm/ft in	3,640/11'11"
Ø Diameter	mm/ft in	365/ 1' 2"
Weight	kg/lb	2 x 1,340/2 x 2,954

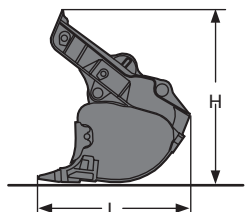

Bottom Dump Bucket

Application		HD
Capacity ISO 7451	m ³ /yd ³	15.00/19.62
L Length	mm/ft in	3,600/11'9"
H Height	mm/ft in	3,900/12'9"
Width	mm/ft in	3,800/12'5"
Weight	kg/lb	27,000/59,525

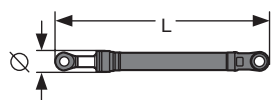

Bucket Tilt Cylinder (two)

L Length	mm/ft in	3,830/12'6"
Ø Diameter	mm/ft in	365/ 1'2"
Weight	kg/lb	2 x 1,545/2 x 3,406

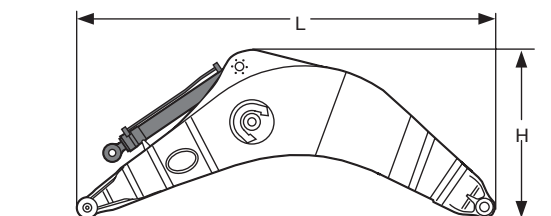

Gooseneck Boom with Stick Cylinders

L Length	mm/ft in	9,600/31'5"
H Height	mm/ft in	3,900/12'9"
Width	mm/ft in	2,200/ 7'2"
Weight	kg/lb	24,500/54,013

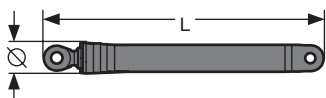

Backhoe Hoist Cylinders (two)

L Length	mm/ft in	4,580/15'
Ø Diameter	mm/ft in	500/ 1'7"
Weight	kg/lb	2 x 3,140/2 x 6,923

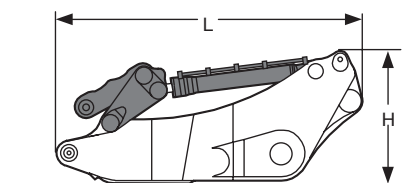

Stick with Bucket Cylinders

L Length	mm/ft in	5,900/19'4"
H Height	mm/ft in	2,600/ 8'6"
Width	mm/ft in	2,000/ 6'6"
Weight	kg/lb	16,020/35,318

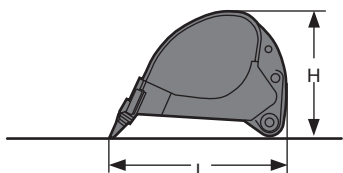

Backhoe Bucket

Application		HD
Capacity ISO 7451	m ³ /yd ³	15.00/19.62
L Length	mm/ft in	3,900/12'9"
H Height	mm/ft in	2,900/ 9'6"
Width	mm/ft in	3,400/11'1"
Weight	kg/lb	13,150/28,991

The Liebherr Group of Companies

Wide product range

The Liebherr Group is one of the largest construction equipment manufacturers in the world. Liebherr's high-value products and services enjoy a high reputation in many other fields, too. The wide range includes domestic appliances, aerospace and transportation systems, machine tools and maritime cranes.

Exceptional customer benefit

Every product line provides a complete range of models in many different versions. With both their technical excellence and acknowledged quality, Liebherr products offer a maximum of customer benefits in practical application.

State-of-the-art technology

To provide consistent, top quality products, Liebherr attaches great importance to each product area, its components and core technologies. Important modules and components are developed and manufactured in-house, for instance the entire drive and control technology for construction equipment.

Worldwide and independent

Hans Liebherr founded the Liebherr family company in 1949. Since that time, the enterprise has steadily grown to a group of more than 100 companies with over 32,000 employees located on all continents. The corporate headquarters of the Group is Liebherr-International AG in Bulle, Switzerland. The Liebherr family is the sole owner of the company.

www.liebherr.com



Printed in Germany by DWS RG-BK-RP LFR/SP 11003236-2-03.10_enGB-US

Liebherr-France SAS Mining Division

49 rue Frédéric Hartmann, CS 50038, F-68025 Colmar Cedex

☎ +33 369 4921 99, Fax +33 369 4922 79

www.liebherr.com, E-Mail: info.lfr-mining@liebherr.com